

GENERAL CATALOG

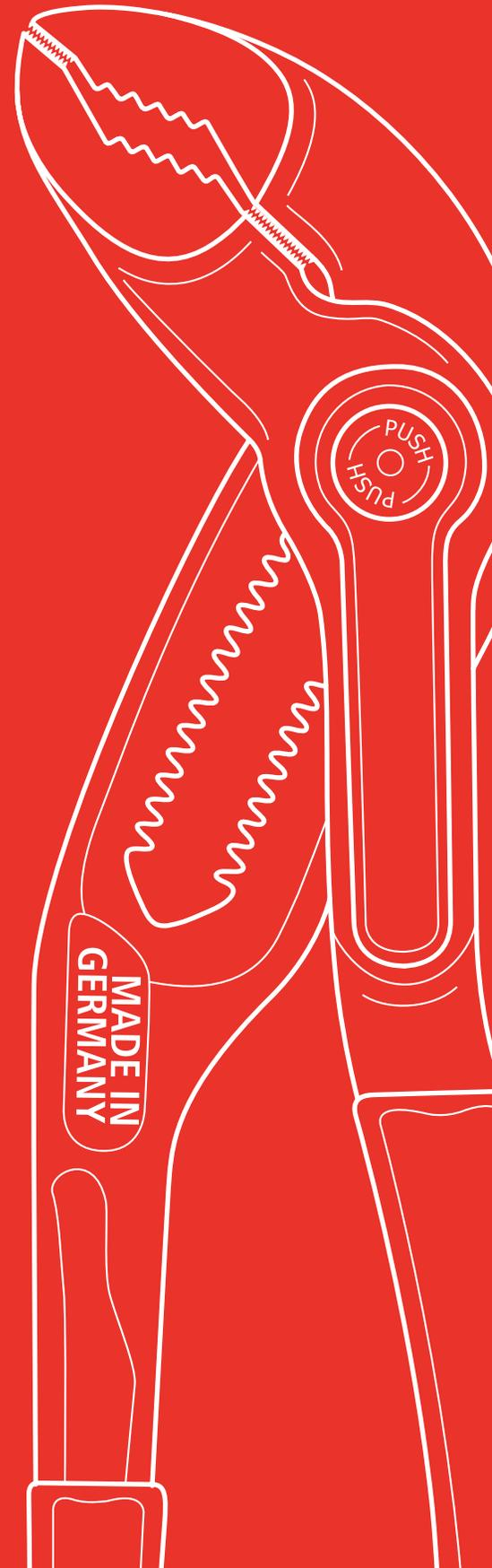

Pliers

MADE IN GERMANY SINCE 1882



The pliers company

KNIPEX Quality – Made in Germany





KNIPEX für den Mann vom Fach

1965

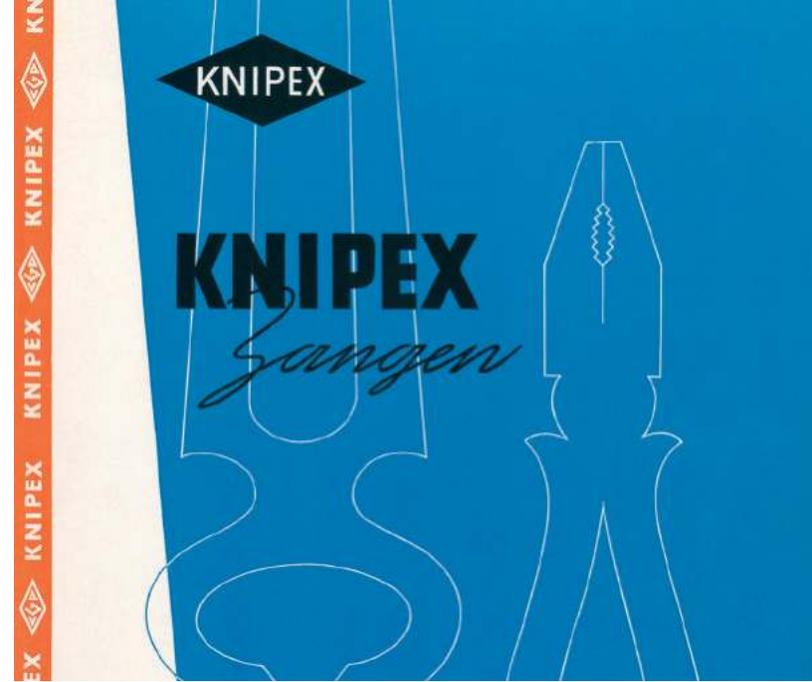

KNIPEX

KNIPEX
Zangen

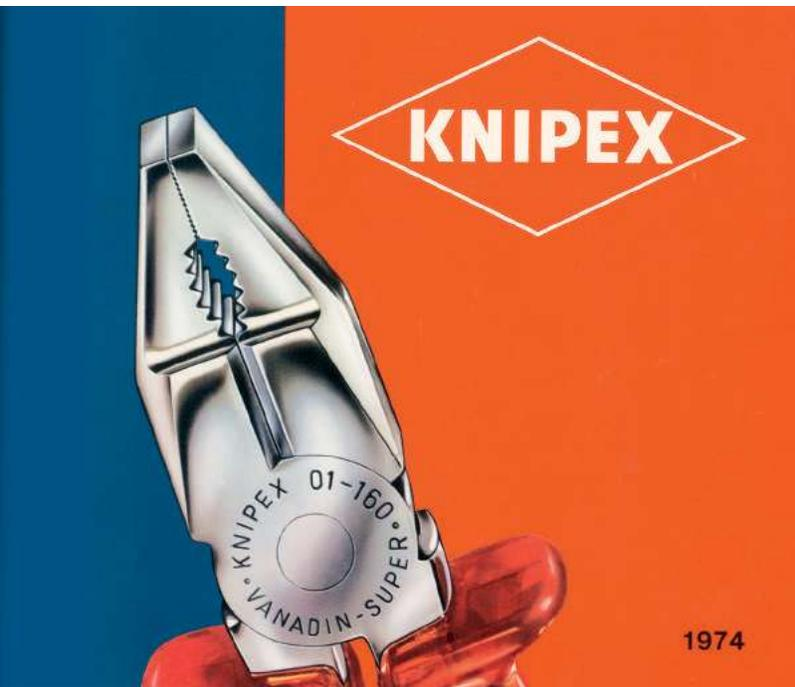

KNIPEX

KNIPEX 01-160 • R
• VANADIN-SUPER

1974

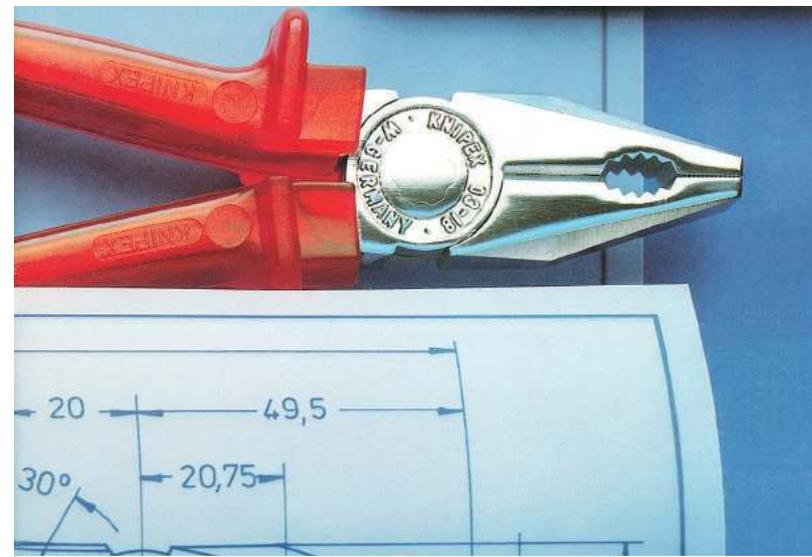

KNIPEX Pliers.
German craftsmanship
from design to production.

Catalogue 1985
2nd edition



Tarif des pinces et Tenailles
Septembre 1952



KATALOG 1939

C-GUST-PUTSCH
ZANGENFABRIK
WUPPERTAL-CRONENBERG

KNIPEX – the company behind the pliers.

For over 130 years and four generations, we have been working passionately on being the best manufacturer of pliers for our customers and users – with a clear focus, high demands and a constant flow of new ideas. Throughout the world, our brand enjoys a great deal of trust, and we aim to consistently meet and rebuild this.

Success is important to us, but is not something we look for at any price. We are guided by values, orientate our actions towards sustainability, and face up to our responsibility towards society and the natural environment in which and with which we live. We invest heavily in the efficiency of our location and the qualification of our employees, working today on the success of tomorrow and the day after that – so that we can also continue to be a strong and reliable partner in the future.

Yours, *Ralf Putsch*



Ralf Putsch, Managing Partner.

1



CoBolt® XL

2



Cobra®

3



Electrical Installation Pliers

4



X-Cut®

5



Pliers Wrench

6



TwinForce®

7



Bolt End Cutting Nippers

8



Spring Hose Clamp Pliers

KNIPEX pliers are different: ideas for improved use and performance.

Ever better pliers – that is our guiding principle to which we devote all of our expertise and creativity. We are not satisfied with standard solutions, but rather continuously develop new and improved models that are better to work with and easier to use.

Working this way means that sometimes we find unconventional solutions to situations, which then go on to set new benchmarks in the industry: novel methods of power transmission, easier and faster handling, combining various functions in a single tool and imaginative problem solvers for special applications. These new benchmarks save our users energy and time, giving them better work results with less effort.

In addition to major innovations, we work continuously on reworking our current product models to improve their function, ergonomics and service life.

- 1 Compact force:** CoBolt® XL – two-hand operation for maximum cutting force.
- 2 Easy operation:** Cobra® – fast grip, precise adjustment, push-button, self-locking.
- 3 Multifunctional:** Electrical Installation Pliers – six functions in one pair of pliers.
- 4 Universal cutting force:** X-Cut® – the first high leverage diagonal cutter with box joint and precision cutting edges.
- 5 Speed and versatility:** Pliers Wrench – turns, holds, bends and presses without damaging materials.
- 6 High performance cutting edges:** TwinForce® – high strength due to unique transmission.
- 7 Redefined end cutting nippers:** Bolt End Cutting Nippers – light, slim, cut directly on the pivot point.
- 8 Problem-solver:** Spring Hose Clamp Pliers – the only pliers for all spring clamps; apply safely from all angles.

Step by step: from idea to product.

A large number of steps lie between an initial idea and the finished product. We never lose sight of the fact that every new or redevelopment must represent a noticeable improvement for the user. We deploy the most up to date technologies and processes when putting our ideas into practice.

We begin by carefully establishing the requirements and selecting the best concepts. The tool is constructed on a computer and the function is simulated with the help of special software. This is followed by the first models made on a 3D printer and by milling and extensive tests on steel prototypes – working closely with experienced users. The first products manufactured using production processes are subjected to additional extensive tests – under conditions far more stringent than normal load.



The locking mechanism on the Spring Hose Clamp Pliers permits simple and safe work, even with closed clamps. Modern CAD technology simulates the mechanism on the screen.

Filip Marovic, project manager for KNIPEX Product Development – “It can be seen repeatedly during the development cycles how important even the smallest detail can be. This is the very thing that motivates me to find creative new solutions. During the process we also take new technical possibilities in processing technology and materials into consideration.”



Core qualities: steel – and what we make from it.

You can expect a great deal more from a pair of KNIPEX pliers. This starts with the material. The many models of pliers in our range are designed for different requirements and loads. We use steel alloys that have been specially selected for the application and rolled according to our high specifications. Long lasting cutting capability when working with very hard wires, strength when working with high torque loads, and good resistance to corrosion are examples of these targets.

The respective materials are then given their specific molecular structure in a number of coordinated heat treatment steps to produce the optimal relationship between hardness and toughness. These processes allow us to achieve the high degree of reliability, durability, and service life that are the very definition of KNIPEX pliers.

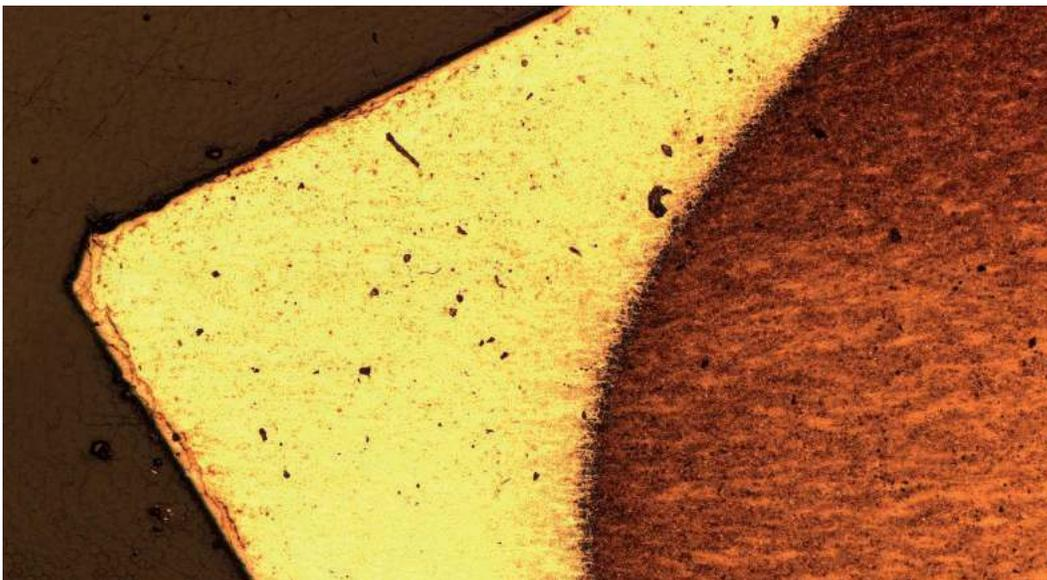

Macro image of a cutter after induction hardening. The specially hardened cutting area (light) is in sharp contrast to the softer structure of the body of the pliers (dark).



Alligator® Water Pump Pliers
being forged by a hydraulic
driven drop-forging hammer.



This is how our pliers are given their shape: hot and under high pressure.

Forging as a forming process is an old cultural technique and continues to hold fascination today. With an impact of up to five and a half tons, the yellow glowing piece of steel is pounded in the upper and lower die at a temperature of 2,282°F. This gives it its basic shape and simultaneously a well-compacted structure.

The production of the forging die in our tool making requires a great deal of experience and high precision, as this raw component will be crucial to the subsequent quality of the pliers. The contours of the forged component are milled at processing centers in the hardened and high strength die block.



Forging die for the high leverage diagonal cutters with forged-in axle.

The technology behind the pliers: machines made by KNIPEX.

Tools can only be as good as the production technology used to manufacture them. In other words, there cannot be superior products without advances in production processes.

Due to our specialization, we can focus on the technologies needed to produce high quality pliers efficiently. We have more than 400 machines built with the specialized knowledge of generations. We build many of the machines ourselves or adapt machines precisely to our high standards using components we have manufactured. We even program the software for the control and operation of the machinery ourselves.

From the product idea to the dispatch of the finished pliers to our customers: everything is done under one roof. This way we can directly influence all steps of value creation ourselves in terms of quality and efficiency, and make continuous improvements. Short distances and direct contact simplify the coordination of processes and communication between employees.



We ensure our high standards by developing our own processes and machinery.



Efficiently coordinated
processes and machinery.

Over 45,000 pairs of
different models of
pliers leave our factory
every day.

Only after several test cuts, does a pair of KNIPEX cutting pliers leave our factory.



We take it very literally: 100% reliability.

The precision of pliers is essential for their function: without accuracy there can be no reliable cutting, gripping, bending and zero backlash. The tight tolerances, which we make sure are complied with through the use of modern production technology, enable us to meet our stringent quality specifications.

We ensure compliance through strict measurements and diverse inspections – after the various production steps and at the end of the entire process. To do this we use the most up-to-date measurement technology and endurance tests – as well as the practical component test by hand.



Shape and roughness of the diagonal cutter's cutting edge are precisely measured with an optical 3D measuring system.

More than excellent pliers: what else you can expect from us.

Quality does not stop with the product. Trust, reliability and a collaborative approach define our business relationships – with consistent customer focus, good service and competent field staff. We provide advice and training, and supply you with extensive digital product data adapted to your specific requirements. Added to this are diverse possibilities for sales support.

You will not find the breadth and depth of our range with any other manufacturer worldwide – that's how we ensure that your customers can always find the tool they are looking for.



We present the breadth and depth of our range at in-house exhibitions and open house days.

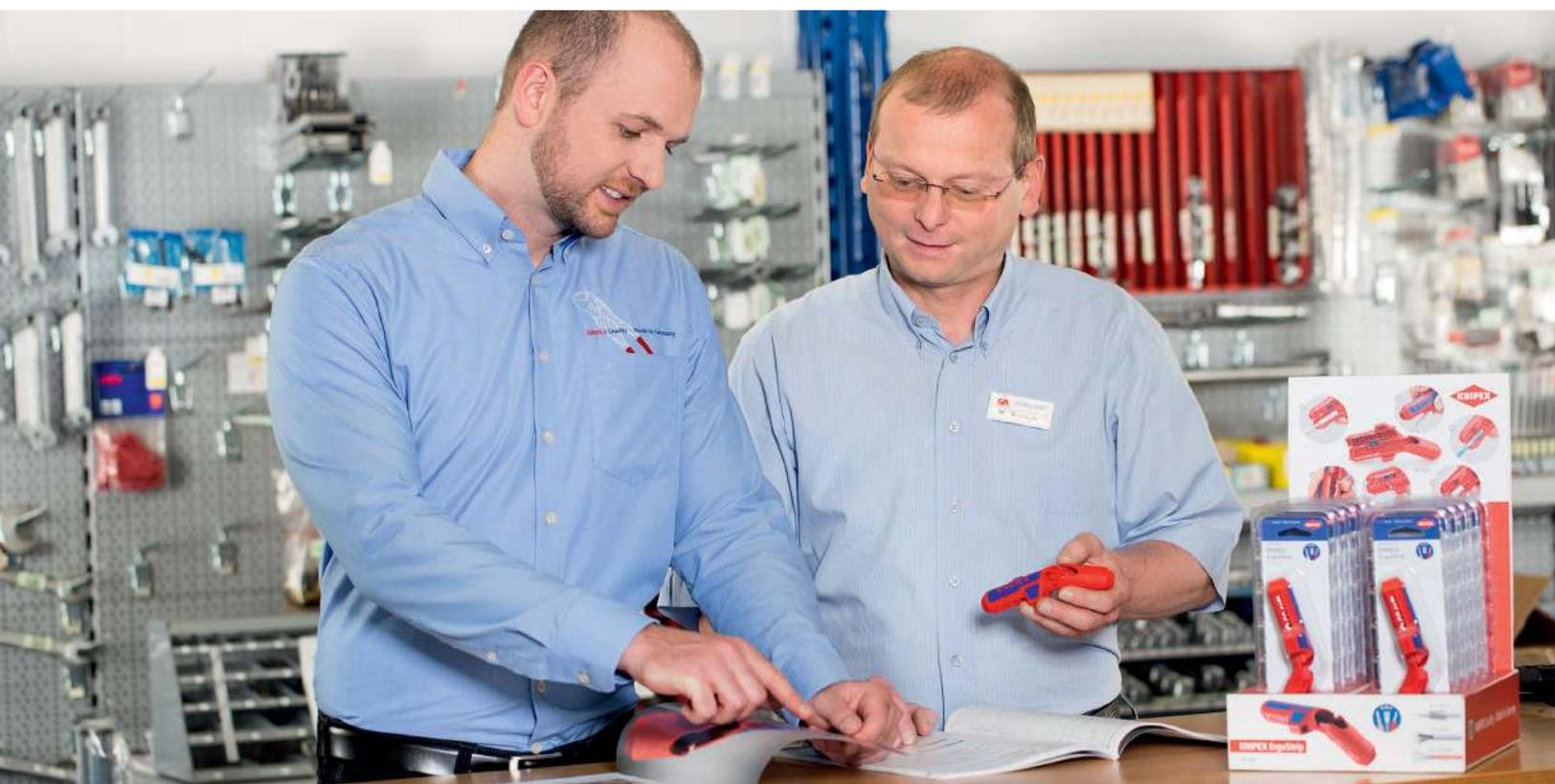



At home in the world: locations in more than 100 countries for you.

KNIPEX is the global pliers brand. We are present in all continents, with a dense network of customers, representatives, and branches. In order to be closer to our retailers and be able to give them even better support, we are further extending our international activities all the time.

There is no substitute for direct contact, which is why we are there for you personally at more than 100 trade shows each year. With the help of the most varied media – classic and digital – we provide comprehensive information about our range and application opportunities in over 30 languages. We reach users and fans throughout the world via social media and hundreds of KNIPEX online videos.

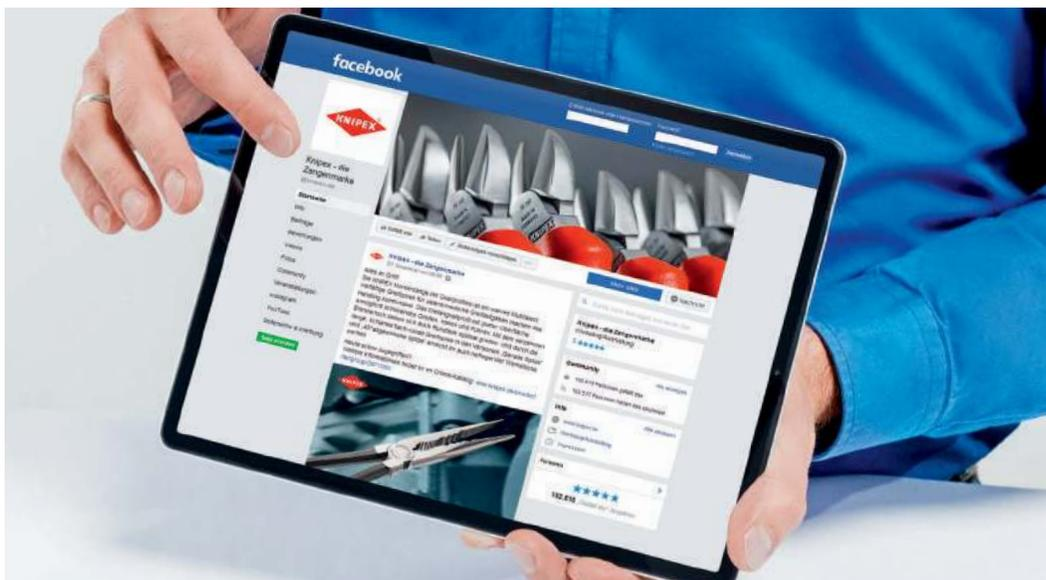

We make up-to-date information available digitally in several languages.

The key factor: our employees.

The most important basis of our success is our employees. Their knowledge and skills, their dedication and their ideas are crucial to our efficiency and thus to our future.

As a company, we are a social community. We want to shape our culture in such a way that allows our employees to participate and create identity through their work but also as individuals. We create good conditions for our employees to develop their potential, to obtain further qualifications and to stay healthy. It is also important to us that our employees are able to successfully balance family and career.

We invest a significant amount of both expense and care in the training of young people, but also impart a wide spectrum of professional and personal skills to other employees.



Our junior staff obtain their qualifications in our own modern training workshop.





Acting responsibly – sustainable management.



As a company, we believe we share responsibility for our natural environment and the well-being of society. We interact with both in various ways. We consume resources, but take care to use them as carefully as possible, and want to make a contribution to ensuring that they are available to future generations in the same – or wherever possible – a better form.

Our ecological objectives include a continuous reduction in our energy consumption, reduction in the volumes of waste and caring for the biodiversity at our site. In addition, we participate in major climate protection projects.

Companies should also be good citizens. We support numerous institutions and organizations in the areas of education and culture. We maintain a close exchange with schools and universities, and strengthen civic engagement in our region in diverse ways.



We support the Bergische music school in the "Singpause" project which, with the help of specially trained teachers, communicates the foundations of music and pleasure by singing together in schools.

27-31 **Combination and Lineman's Pliers**
Combination Pliers | Needle –Nose Combo Pliers | Lineman's Pliers



32 **Ear Clamp Pliers**
Single Jaw | Dual Jaw Ear Clamp Pliers



33-50 **Wire Strippers and Dismantling Tools**
Installation Strippers | Self-Adjusting / MultiStrip 10 | Automatic |
Electrician's Installation Pliers | Dismantling Tools | ErgoStrip®



51-61 **Long Nose Pliers**
Round Nose Pliers | Flat Nose Pliers | Snip Nose Pliers | Long Reach Needle Nose Pliers



62-67 **Electronics Gripping Pliers**
Precision Electronics Gripping Pliers | Mounting Pliers



68-72 **Gripping and Mechanics Pliers**
Universal Grip Pliers | Welding Grip Pliers



73-81 **Circlip Pliers**
Circlip Pliers | Precision Circlip Pliers



82-87 **Pincers and Nippers**
Carpenters' Pincers | Concreters' Nippers | End Cutting Nippers



88-92 **Bolt Cutters**
CoBolt® Compact Bolt Cutters | CoBolt XL | Bolt Cutters | Concrete Mesh Cutter



93-102 **Diagonal Pliers**
Flush Cutters | X-Cut® | TwinForce® | High Leverage Diagonal Cutters | Center Cutter



103-121 **Electronics Diagonal Cutters**
End Cutting Nippers | Diagonal Cutters | Carbide Tip Diagonal Cutters |
Super Knips® | Super Knips XL



122-141

Pipe Wrenches and Water Pump Pliers

Pipe Wrenches | Hose Clamp Pliers | Pliers Wrenches | Cobra® | Alligator®



142-148

Specialty Pliers

End Cutting Nippers | Diagonal Cutters | Carbide Tip Diagonal Cutters | Super Knips® | Super Knips XL



149-154

Tweezers

Precision | Insulated | Plastic | Crossover

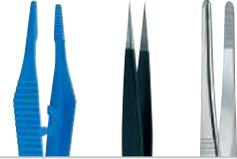

155-158

Pipe Cutters and Special Shears

Mitre Shears | Anvil Shears | Kevlar® Fibers Shears | Electricians' Shears



158-169

Cable Cutters and Wire Rope Cutters

Twin Cutting Edge | Ratcheting | ACSR | Wire Rope Shears and Cutters



170-191

Crimping Pliers

MultiCrimp® | PreciForce® | Four-Mandrel | Twistor 16



192-195

Control Cabinet Keys and LED Light

TinwKey® | Profi-Key | Universal Key



196-205

Tool Sets and Carriers

Tool Rolls with Tools | Top Selling Tool Sets | Electronics Pliers Sets



206-211

Tether Tool System



212-249

Insulated Tools and Sets



250-264

Index / Article Number | Index | Pliers-ABC | Symbols



KNIPPEX

High Leverage Combination Pliers

DIN ISO 5746

02

35% less effort required than with conventional combination pliers
Cutting edge hardness (approx. 63 HRC) for heavy-duty cutting

- > easier work due to high leverage design
- > easier cutting, powerful gripping, bending and pulling
- > long cutting edges for thicker cables
- > gripping zones for flat and round material for a variety of uses
- > high-grade special tool steel; forged, multi stage oil-hardened

02 02 225 T BKA*

Pliers with integrated tether attachment point for tool drop protection system



02 01 180



02 02 180



02 02 225 T BKA



02 08 200 US



Product Number	Packaging	↔ Inch mm		Pliers	Head	Handles	Cutting capacities				
							Ø Inch Ø mm	Ø Inch Ø mm	Ø Inch Ø mm	mm ²	lbs
02 01 180		7 1/4 180					3/32 2.5	5/64 2.0	29/64 11.5	16.0	0.45
02 01 200	X	8 200		black atramentized	polished	plastic coated	7/64 2.8	3/32 2.2	1/2 13.0	25.0	0.66
02 01 225	X	9 225					1/8 3.0	3/32 2.5	35/64 14.0	25.0	0.79
02 02 180	X	7 1/4 180					3/32 2.5	5/64 2.0	29/64 11.5	16.0	0.53
02 02 200	X	8 200		black atramentized	polished	multi-component grips	7/64 2.8	3/32 2.2	1/2 13.0	25.0	0.75
02 02 225	X	9 225					1/8 3.0	3/32 2.5	35/64 14.0	25.0	0.90
02 02 225 T BKA	X	9 225		black atramentized	polished	multi-component grips, integrated tether attachment point	1/8 3.0	3/32 2.5	35/64 14.0	25.0	0.95
02 08 200 US	X	8 200		black atramentized	polished	insulated, multi-component grips, ASTM-tested	7/64 2.8	3/32 2.2	1/2 13.0	25.0	0.82
02 08 225 US	X	9 225					1/8 3.0	3/32 2.5	35/64 14.0	25.0	0.95

*Learn more about our tethered tool system on pages 207-211

Combination Pliers

DIN ISO 5746

03

- > gripping zones for flat and round material for a variety of uses
- > cutting edges for soft and hard wire
- > long cutting edges for thicker cables
- > cutting edge hardness (approx. 60 HRC)
- > special tool steel; forged, multi stage oil-hardened



03 01 180



03 02 180



03 08 200 SBA



Product Number	Packaging	↔ Inch mm		Pliers	Head	Handles	Cutting capacities				
							● Ø Inch Ø mm	◐ Ø Inch Ø mm	◑ Ø Inch Ø mm	⊗ mm ²	⚖ lbs
03 01 140		5 1/2 140					7/64 2.8	5/64 1.8	23/64 9.0	10.0	0.25
03 01 160		6 1/4 160					1/8 3.1	5/64 2.0	25/64 10.0	16.0	0.41
03 01 180		7 1/4 180		black atramentized	polished	plastic coated	9/64 3.4	3/32 2.2	15/32 12.0	16.0	0.48
03 01 200	X	8 200					5/32 3.8	3/32 2.5	1/2 13.0	16.0	0.61
03 01 250		10 250					5/32 3.8	3/32 2.5	19/32 15.0	25.0	1.04
03 02 160		6 1/4 160					1/8 3.1	5/64 2.0	25/64 10.0	16.0	0.49
03 02 180		7 1/4 180		black atramentized	polished	multi-component grips	9/64 3.4	3/32 2.2	15/32 12.0	16.0	0.56
03 02 200		8 200					5/32 3.8	3/32 2.5	1/2 13.0	16.0	0.71
03 08 160 SBA	X	6 1/4 160		black atramentized	polished	insulated, multi-component grips, ASTM-tested	1/8 3.1	5/64 2.0	25/64 10.0	16.0	0.55
03 08 200 SBA	X	8 200		black atramentized	polished	insulated, multi-component grips, ASTM-tested	5/32 3.8	3/32 2.5	1/2 13.0	16.0	0.76

Needle-Nose Combination Pliers

DIN ISO 5746

08

Small high leverage combination pliers with pointed jaws For all common installation and repair work

Handy for use when working in confined areas due to slim head design and pointed jaws (anti-twist)

Gripping surfaces with special convex contour on one side for secure gripping of flat parts

Milled groove in the gripping area permits small parts such as nails, pins and bolts to be held and pulled

- > easy cutting due to the high leverage joint
- > cutting edges for soft, medium hard and hard wire
- > long service life and stable tips
- > high-grade special tool steel; forged, multi stage oil-hardened

08 22 145 T BKA*

Pliers with integrated tether attachment point for tool drop protection system



Milled groove in the gripping area

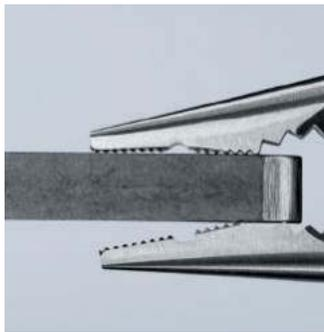

Firm grip on flat material due to three-point contact



Easy cutting thanks to the high leverage joint



Anti-twist tips remain stable even under high strain



08 21 145

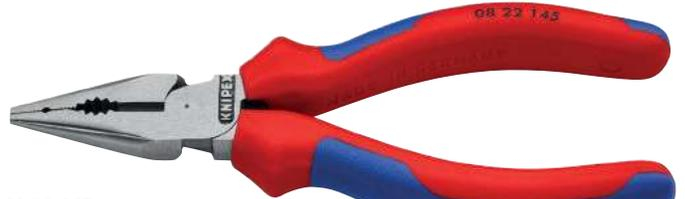

08 22 145



08 22 145 T BKA



08 28 145 US



Product Number	Packaging	↔ Inch mm	Pliers	Head	Handles	Cutting capacities					
						Ø Inch Ø mm	Ø Inch Ø mm	Ø Inch Ø mm	mm ²	lbs	
08 21 145	X	5 3/4 145		black atramentized	polished	plastic coated	1/8 3.0	5/64 2.0	5/16 8.0	16.0	0.26
08 22 145	X	5 3/4 145		black atramentized	polished	multi-component grips	1/8 3.0	5/64 2.0	5/16 8.0	16.0	0.32
08 22 145 T BKA	X	5 3/4 145		black atramentized	polished	multi-component grips, integrated tether attachment point	1/8 3.0	5/64 2.0	5/16 8.0	16.0	0.39
08 28 145 US	X	5 3/4 145		black atramentized	polished	insulated, multi-component grips, ASTM-tested	1/8 3.0	5/64 2.0	5/16 8.0	16.0	0.39

*Learn more about our tethered tool system on pages 207-211

Lineman's Pliers

DIN ISO 5746 ASME B107.20

09

High transmission ratio for easy cutting.

High leverage design requires 50% less effort compared to conventional combination pliers due to an optimized transmission ratio.

- > heavy-duty
- > ergonomically optimized handle shape for firm contact to the hand and fatigue reducing operation
- > effective cross-hatched knurled gripping zone in the jaws – for strong gripping and pulling
- > serrated gripping zone below the joint for powerful leverage
- > cutting edges for soft and hard wire, nails, ACSR and piano wire
- > cutting edge hardness (approx. 64 HRC)
- > vanadium steel, forged, multi stage oil-hardened

09 11 240 / 09 12 240 / 09 12 240 T BKA*

With fish tape puller in the joint gap; with universal crimping point below the joint

09 02 240 T BKA / 09 12 240 T BKA*

Pliers with integrated tether attachment point for tool drop protection system



Gripping zone below the joint for powerful leverage



09 01 240



09 02 240



09 02 240 T BKA



09 08 240 US



09 11 240



09 12 240 T BKA





09 11/12 240:
Universal crimping area below the joint



09 11/12 240:
Fish tape puller in the joint gap



Cross-hatched, knurled gripping zone for firm gripping and pulling, e. g. for fence construction



Long cutting edges for cutting flat cables

Product Number	Packaging	↔ Inch mm		Pliers	Head	Handles	Cutting capacities		⚖ lbs
							Ø Inch Ø mm	Ø Inch Ø mm	
09 01 240	X	9 1/2 240		black atramentized	polished	plastic coated	3/16 4.6	1/8 3.0	0.96
09 02 240	X	9 1/2 240		black atramentized	polished	multi-component grips	3/16 4.6	1/8 3.0	1.01
09 02 240 T BKA	X	9 1/2 240		black atramentized	polished	multi-component grips, integrated tether attachment point	3/16 4.6	1/8 3.0	1.08
09 08 240 US	X	9 1/2 240		black atramentized	polished	insulated, multi-component handles, ASTM-tested	3/16 4.6	1/8 3.0	1.02
09 11 240	X	9 1/2 240		black atramentized	polished	plastic coated	3/16 4.6	1/8 3.0	0.91
09 12 240	X	9 1/2 240		black atramentized	polished	multi-component grips	3/16 4.6	1/8 3.0	1.04
09 12 240 T BKA	X	9 1/2 240		black atramentized	polished	multi-component grips, integrated tether attachment point	3/16 4.6	1/8 3.0	1.07



Suitable for universal use, for 1-ear and 2-ear clamps

- > for the simple and reliable mounting of 1-ear and 2-ear clamps (Oetiker® system or similar)
- > no damage to press points on the ear clamps
- > the slim head permits good accessibility in confined areas
- > versatile use for clamps on CV boots, cooler and fuel lines, air pressure systems, compressors
- > durable and strong
- > high-grade special tool steel; forged, oil-hardened

10 99 I220

Suitable for universal use due to the additional side jaw



10 98 I220



10 99 I220



10 98 I220



Front press jaw



Sealing the fluid hose on the connecting piece



Sealing the pneumatic hose on the quick action coupling



Sealing the hose connection on central lubrication

10 99 I220



Using the front press jaw

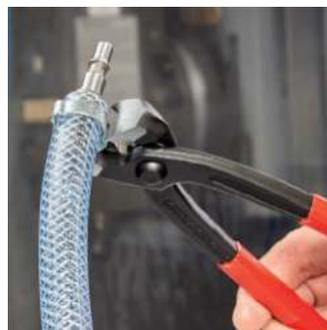

Sealing the pneumatic hose on the quick action coupling using the side press jaw



Using the side press jaw



Sealing the fluid hose on the connecting piece using the side press jaw

Product Number	Packaging	↔ Inch mm	Pliers	Head	Handles	⚖️ lbs
10 98 I220		8 3/4 220	black atramentized	polished	plastic coated	0.78
10 99 I220		8 3/4 220	black atramentized	polished	plastic coated	0.75

- > for single, multi and fine-stranded conductors with plastic or rubber insulation max. 13/64" (5.0 mm) dia., suitable up to 8 AWG wire
- > easy adjustment to the required diameter of solid or stranded wire with knurled screw and lock nut
- > special tool steel; forged, oil-hardened

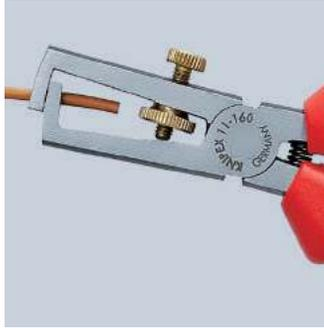

11 01 160



11 02 160





11 08 160 SBA
 1000V ASTM 

WARNING: This product can expose you to chemicals including lead, which is known to the State of California to cause cancer. For more information go to www.P65Warnings.ca.gov

Prismatic blade

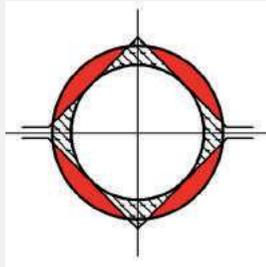
The red area is cut over four surfaces. Works with highly-elastic materials also.



Product Number	Packaging	↔ Inch mm		Pliers	Head	Handles	Stripping capacities Ø Inch Ø mm	Stripping capacities mm ²	AWG	⚖ lbs
11 01 160		6 1/4 160		black atramentized	polished	non-slip plastic coated	13/64 5.0	10.0	up to 8	0.32
11 02 160		6 1/4 160		black atramentized	polished	multi-component grips	13/64 5.0	10.0	up to 8	0.38
11 08 160 SBA	X	6 1/4 160	 1000V ASTM 	black atramentized	polished	insulated, multi-component grips, ASTM tested	13/64 5.0	10.0	up to 8	0.40

Electronics Wire Stripping Shears

11
8

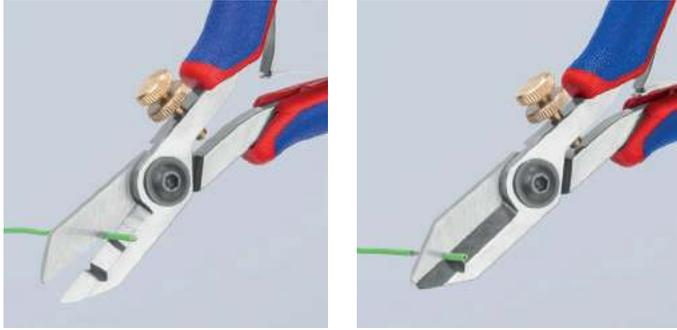

- > for cutting and stripping solid, multi and fine-stranded conductors with a diameter up to 3/64" (18-32 AWG)
- > pointed head of shears above the wire stripping hole for the accurate cutting of fine wire in confined places
- > easy adjustment to the required diameter of solid or stranded wire with knurled screw and lock nut
- > opening spring for easy repetitive work
- > special tool steel; oil-hardened



11 82 130
⊗ M

WARNING: This product can expose you to chemicals including lead, which is known to the State of California to cause cancer. For more information go to www.P65Warnings.ca.gov

Product Number	Packaging	↔ Inch mm		Head	Handles	Stripping capacities Ø Inch Ø mm	Stripping capacities AWG mm ²	⚖ lbs
11 82 130		5 1/4 130	⊗ M	polished	multi-component grips	up to 3/64 0.03-1.19	32-18 0.01-0.75	0.20

Electronics Wire Stripper

11
9

- > for single, multi and fine stranded cables having a diameter up to 1/32" (0.1 up to 0.8 mm), with plastic or rubber insulation
- > easy adjustment to the required diameter of solid or stranded wire with knurled screw and lock nut
- > opening spring for easy repetitive work
- > the mirror polish and fine film of oil offer effective rust protection – no circuit faults caused by peeling chrome from plated tools
- > special tool steel, forged, oil-hardened

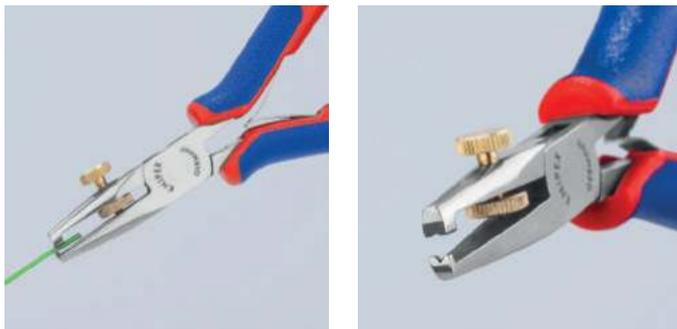

11 92 140
⊗ M

WARNING: This product can expose you to chemicals including lead, which is known to the State of California to cause cancer. For more information go to www.P65Warnings.ca.gov

Product Number	Packaging	↔ Inch mm		Head	Handles	Stripping capacities AWG mm ²	⚖ lbs
11 92 140		5 1/2 140	⊗ M	mirror polished	multi-component grips	38 - 20 0.1 - 0.8	0.22

Insulation Stripper

with replaceable blades

12

- > leaves wire undamaged due to precision-ground blade shapes, even multi-stranded conductors are stripped gently
- > during stripping, the wire is held firmly by clamping jaws
- > with adjustable length stop for consistent stripping length during repetitive work
- > a spring leads the stripper back to the starting position
- > pliers body: aluminum
- > blade: special tool steel; oil-hardened

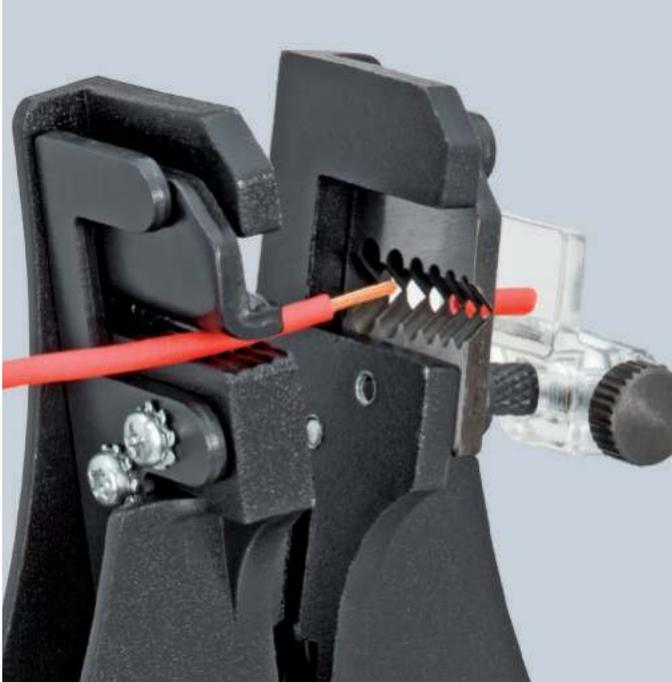

Adjustable length stop for repetitive work



12 11 180
MM



12 21 180
MM



12 11 180: wire cross-sections in inches

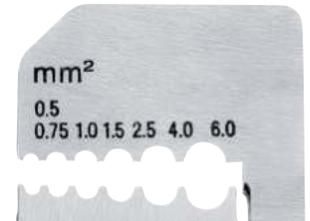

12 21 180: wire cross-sections in mm²

Product Number	Packaging	↔ Inch mm	Pliers	Handles	Stripping capacities		⚖ lbs	
					mm	mm ²		
12 11 180		7 1/4 180	MM	black lacquered	with plastic grips	0.5 / 1.2 / 1.6 / 2.0	-	0.80
12 21 180		7 1/4 180	MM	black lacquered	with plastic grips	-	0.5-0.75 / 1.0 / 1.5 / 2.5 / 4.0 / 6.0	0.81
12 19 180	1 pair of spare blades for 12 11 180							
12 29 180	1 pair of spare blades for 12 21 180							

Precision Insulation Strippers

with replaceable blades

12
12

- > form-fit stripping of both standard and difficult-to-remove insulating materials made of PTFE, silicone, Radox®, Kapton® and rubber including multi-layer insulations
- > a second pair of blades holds the remaining insulation reliably in place
- > replaceable shaped blade adapted precisely to the respective conductor diameter
- > includes length stop for consistent stripping length during repetitive work
- > pliers body: steel
- > blade: special tool steel; oil-hardened



12 12 02
PATENTED



12 12 02 is the only Precision Installation Strippers that has the cable guide



Precise, complete clean cut of the insulation



12 12 12
PATENTED



Quality stripping due to precise shape of the blades

12 12 02
The only tool with the cable guide for exact positioning of the cable in the stripping area of the blade

12 12 11
For solar cables; specially adapted to multi-layered and RADOX® insulations; with additional cable support for a better centering in the stripping profiles

12 12 13 / 12 12 14
For cables according to US specifications (AWG)

Maximum cable cross-section (in mm²) per profile:

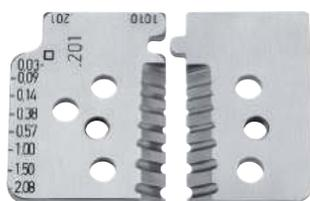

12 12 02



12 12 06

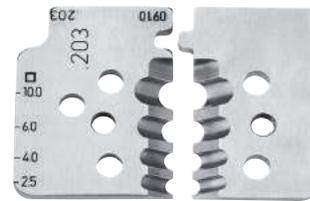

12 12 10

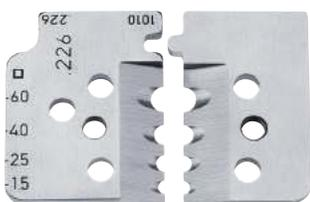

12 12 11

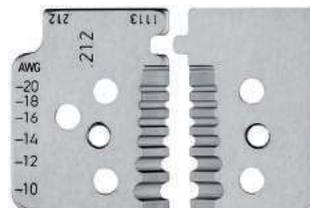

12 12 13 - AWG Version

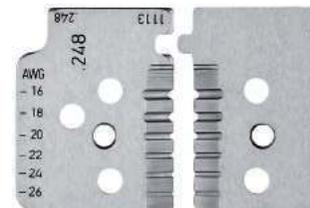

12 12 14 - AWG Version

Radox® is a registered trademark of Huber & Suhner AG
Kapton® is a registered trademark of E. I. du Pont de Nemours and Company

Principle of operation with shaped blades

Proper and precise stripping with an annular cut through the complete insulation. This is particularly important with conductors, which must be stripped precisely.

This works without any problem even with difficult insulating materials made of PTFE, Radox® and multi-layer insulations.

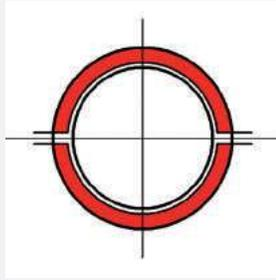

Precise and Reliable

Two pairs of blades (1) completely cut the insulation.

Then the blade pairs move apart, and the insulation is removed (2). The pliers opens automatically after the stripping procedure.

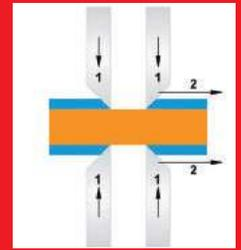

Product Number	Packaging	↔ Inch mm	Pliers	Handles	Stripping capacities mm ²	AWG	⚖ lbs	
12 12 02		7 3/4 195	MM	burnished	multi-component grips	-	0.99	
12 12 06		7 3/4 195						0.03-0.09 / 0.14 / 0.38 / 0.57 / 1.0 / 1.5 / 2.08
12 12 10		7 3/4 195						0.14-0.25 / 0.75 / 1.5 / 2.5 / 4.0 / 6.0
12 12 11		7 3/4 195	MM	burnished	multi-component grips	-	0.98	
12 12 13		7 3/4 195	MM	burnished	-	10 / 12 / 14 / 16 / 18 / 20	0.99	
12 12 14		7 3/4 195				16 / 18 / 20 / 22 / 24 / 26	0.99	



- > for single, multi and fine-stranded wire cables with plastic or rubber insulation; especially useful with THHN coated wire
- > adapts automatically to the respective cable diameter preventing damage to the conductor
- > cutting depth can be adjusted for different insulation by turning the red wheel
- > includes wire cutter for copper and aluminum wires, multi-stranded up to 8 AWG (10 mm²) and single stranded up to 10 AWG (6 mm²)
- > smooth operating mechanism
- > replaceable blade and plastic clamping jaws
- > the body is constructed of lightweight fiberglass-reinforced plastic
- > blade: special tool steel; oil-hardened



12 40 200
MM

12 40 200

For thin ribbon cables up to 10 mm width in a single pass



12 40 200: Adjustable length stop



12 40 200: Precise stripping prevents damage to the conductor



Wire cutter for multi-stranded wire cables up to 8 AWG (10 mm²)



Product Number	Packaging	↔ Inch mm		Stripping capacities mm ²	AWG	Length stop Inch mm	⚖ lbs
12 40 200	X	8 200	MM	0.03 - 10.0	32 - 8	1/8 - 11/16 3.0 - 18.0	0.45
12 50 200		8 200	MM	2.5 - 16.0	14 - 6	-	0.44
12 49 01	1 pair of spare blades for 12 40 200						
12 49 02	1 pair of spare clamping jaws for 12 40 200						
12 49 03	Spare length stop for 12 40 200						
12 59 01	1 pair of spare blades for 12 50 200						
12 59 02	1 pair of spare clamping jaws for 12 50 200						

Stripping without readjustment from 32–8 AWG
 Universal blade geometry – tough and robust
 Ideal grip design with excellent control
 Recessed wire cutter

- > automatic adjustment to all single-, multi and fine-stranded conductors with standard PVC insulation. Range of 32 AWG (0.03 mm²) to 8 AWG (10.0 mm²)
- > no manual fine adjustment necessary
- > no damage to the conductors
- > steel clamping jaws with integrated cutting edges hold the cable and prevent slipping
- > includes recessed wire cutter for Cu and Al conductors, stranded up to 8 AWG and single wire up to 10 AWG
- > particularly smooth running mechanics and very low weight
- > replaceable blades block and length stop
- > handle with soft-plastic zone for a steady grip
- > the body is constructed of lightweight fiberglass-reinforced plastic
- > blade: special tool steel; oil-hardened
- > **NOT FOR THHN CABLE**



12 42 195

MultiStrip



Wire cutter for multi-stranded wire cables up to 8 AWG (10 mm²)



Steel clamping jaws avoid slipping of the cable

Patented Mechanics

The incision depth of the stripping blade adjusts automatically to the diameter of the wire and to the thickness of all standard insulating materials.

There is no need for any of the manual adjustment still necessary when other conventional pliers with a wide wire-stripping range are used.



Precise stripping from 32–8 AWG without readjustment



Mode of operation of straight cutters

An incision is made in the red area only.

Not suitable for highly-flexible or armored insulation materials or multi-layered insulation such as THHN.

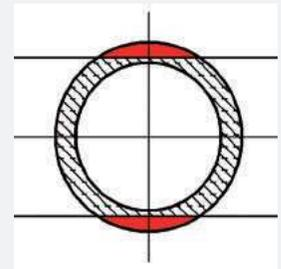

Product Number	Packaging	↔ Inch mm		Stripping capacities mm ²	AWG	⚖️ lbs
12 42 195	X	7 1/2 190	MM	0.03 - 10.0	32 - 8	0.31
12 49 21	Spare blades block for 12 42 195					
12 49 23	Spare length stop for 12 42 195					

Automatic Insulation Stripper

12
62

- > compact standard tool at a favorable price for common cable diameters and insulating materials
- > for single, multi and fine stranded cables of 24 AWG (0.2 mm²) up to 10 AWG (6 mm²) with standard PVC insulation
- > adapts automatically to the respective cable diameter preventing damage to the conductor
- > comfortable and lightweight for easy operation
- > narrow head style for use in confined areas
- > with wire cutter for copper and aluminum wires up to 14 AWG
- > with adjustable length stop from 1/4" – 11/16" (6.0–18.0 mm) for stripping the same lengths during repetitive work
- > the body is constructed of lightweight fiberglass-reinforced plastic
- > blades: special tool steel; oil-hardened, interchangeable



12 62 180
MM

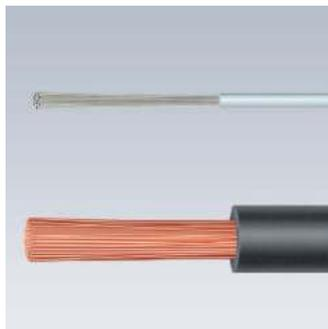

Precise stripping from 24 AWG to 10 AWG (0.2 up to 6.0 mm²)

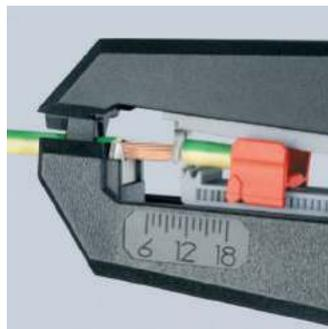

Wire cutter up to 14 AWG (2.5 mm²)



Stripping in confined areas

Product Number	Packaging	↔ Inch mm		Stripping capacities mm ²	AWG	⚖️ lbs
12 62 180	X	7 1/4 180	MM	0.2 - 6.0	24 - 10	0.35
12 69 21	1 pair of spare blades for 12 62 180					
12 69 23	Spare length stop for 12 62 180					

Automatic Flat Cable Stripping Pliers

12
64

- > for PVC-insulated flat cables up to a max. 15/32" (12 mm) width and 18 AWG - 14 AWG (0.75 to 2.5 mm²)
- > adapts automatically to the various conductor heights which prevents damage to the conductor
- > allows long stripping lengths
- > replaceable blades
- > smooth operating mechanism
- > the body is constructed of lightweight fiberglass-reinforced plastic
- > blade: special tool steel; oil-hardened



12 64 180
MM

Product Number	Packaging	↔ Inch mm		Stripping capacities in square inch mm ²	⚖️ lbs
12 64 180		7 1/4 180	MM	0.75 - 2.5	0.27
12 69 31	Spare blades for 12 64 180				

Automatic Stripping Pliers

For multicore cable Ø 4.4 to Ø 7.5 mm
with irregular sheathing cross-section

12
74

For control and sensor cables / actuator cables, also for stripping flexible 3-core feed cables and extension cable

Automatic adjustment to cable diameters between 4.4 and 7.5 mm

No damage to the inner conductor or shield braid

- > allows cable to pass through center of pliers for mid-line strip or stripping longer lengths
- > suitable for highly flexible PUR and PVC cable sheathing and rubber leads such as H05, etc.
- > long stripping lengths possible
- > body: plastic, fiberglass-reinforced
- > exchangeable blades: special tool steel, oil-hardened

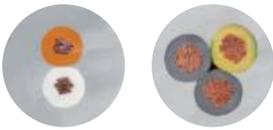

Sectional view of an extension lead



12 74 180 SB



Required stripping length easy to read



Complex cutter design for precise and damage-free stripping of round cables

Product Number	Packaging	↔ mm	Stripping capacities Ø mm	⚖ lbs
12 74 180 SB	X	175	4.4 - 7.5	0.26
12 79 31		1 pair of spare blades for 12 74 180 SB		

Mini Wire Stripper

12
80

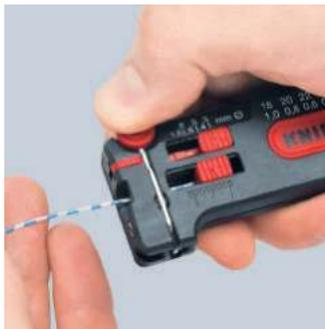

12 80 040 SB

For thin copper conductors dia. 36 – 26 AWG (0.12 to 0.4 mm)

12 80 100 SB

For thin copper conductors dia. 28 – 18 AWG (0.3 – 1.0 mm)

- > precise stripping due to the tool's gradual adjustment to the conductor's diameter
- > includes wire cutter
- > adjustable length stop from 5/32" – 19/32" (4.0 – 15.0 mm)
- > includes locking device
- > housing: plastic, impact-resistant



12 80 100 SB



Product Number	Packaging	↔ Inch mm	Stripping capacities Ø mm	AWG	⚖ lbs
12 80 040 SB	X	4 100	0.12 - 0.4	36 - 26	0.08
12 80 100 SB	X	4 100			

- > the ideal 4-in-1 pliers for cable and wire work
- > for gripping and bending wire
- > for cutting medium and hard wire
- > precision cutting edges induction hardened, cutting edge hardness (approx. 60 HRC)
- > with precision stripping holes
- > for crimping ferrules (end sleeves)
- > vanadium steel; forged, multi-stage oil-hardened

13 02 614 T BKA*

Pliers with integrated tether attachment point for tool drop protection system



Gripping



Cutting



Stripping



Crimping 20-14 AWG (0.5 to 2.5 mm²)



13 01 160



13 01 614



13 02 160



13 02 614 T BKA

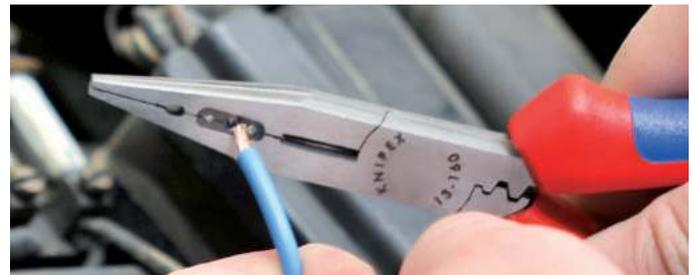

Product Number	Packaging	↔ Inch mm		Pliers	Head	Handles	Cutting capacities		Stripping capacities mm ²	AWG	 lbs
							 Ø Inch Ø mm	 Ø Inch Ø mm			
13 01 160	X	6 1/4 160		black atramentized	polished	non-slip plastic coated	3/32 2.5	1/16 1.6	0.5 - 0.75 / 1.5 / 2.5	-	0.24
13 02 160	X	6 1/4 160		black atramentized	polished	multi-component grips	3/32 2.5	1/16 1.6	0.5 - 0.75 / 1.5 / 2.5	-	0.31
13 01 614	X	6 1/4 160		black atramentized	polished	non-slip plastic coated	3/32 2.5	1/16 1.6	-	10 / 12 / 14	0.25
13 02 614 T BKA	X	6 1/4 160		black atramentized	polished	multi-component grips, integrated tether attachment point	3/32 2.5	1/16 1.6	-	10 / 12 / 14	0.32

Dismantling Pliers

DIN ISO 5746

13

Multifunctional – dismantling, stripping and cutting with one pair of pliers

For time-saving dismantling and stripping of all common round and damp-proof installation cables (e.g. NYM cable)

Simplified access especially to deeply mounted flush sockets due to slim head design and optimally angled cable sheath cutter

Strip cables easily and without damage thanks to circular cutting edge with depth limit

- > dismantles outer sheath of cable easily and without damage due to the circular cutting edge with depth limit
- > precision wire stripping holes for 1.5 and 2.5 mm² conductors
- > integrated diagonal cutters for cutting and trimming conductors, wires, small screws and nails
- > cutting blades induction hardened to (approx. 61 HRC)
- > 30% lighter in weight than comparable pliers
- > slim head design allows for easy access into deeply mounted sockets



Circular cutting edge with depth limit: for easy dismantling without damaging the conductor insulation

13 42 165



Wire stripping holes for 1.5 and 2.5 mm² conductors



Cutting cable up to Ø 13 mm

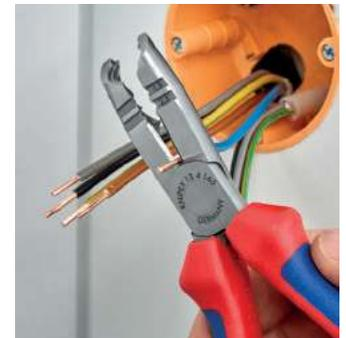

Cutting when shortening single conductors

Product Number	Packaging	↔ Inch mm		Pliers	Head	Handles	Dismantling capacities Ø mm	Stripping capacities Ø mm ²	⊙ Ø mm	⊙ Ø mm	⚖ lbs
13 42 165		6 1/2 165		black atramentized	polished	with multi-component grips	8 - 13	1.5 / 2.5	3.2	2.2	0.39

Insulation strippers with Cable Shears – two essential electrical installation tools in one pair of pliers

- > integrated cable shears for clean cutting of copper and aluminum cables without crushing
- > universal adjustment of the wire stripping blades with knurled screw
- > slim design allows for easy access into confined areas
- > for stripping single, multiple and fine stranded conductors with plastic and rubber insulation up to a max. Ø 5 mm or 10 mm² conductor cross-section
- > Graduated jaw is a visual guide when stripping wire in standard lengths 7/16" (11 mm) and 5/8" (16 mm)



Induction hardened shear blade with precisely ground cutting edges for crushing-free cutting of copper cables up to 9/16" (15 mm Ø) (5 x 2.5 mm²)



Induction hardened precision blade

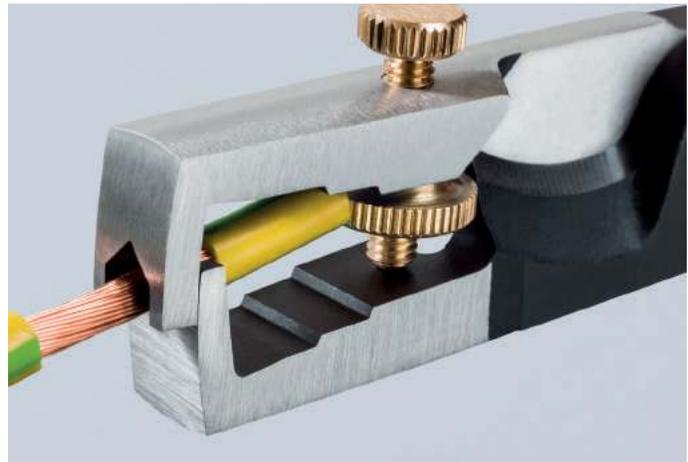

Lock nut prevents any unintentional adjustment

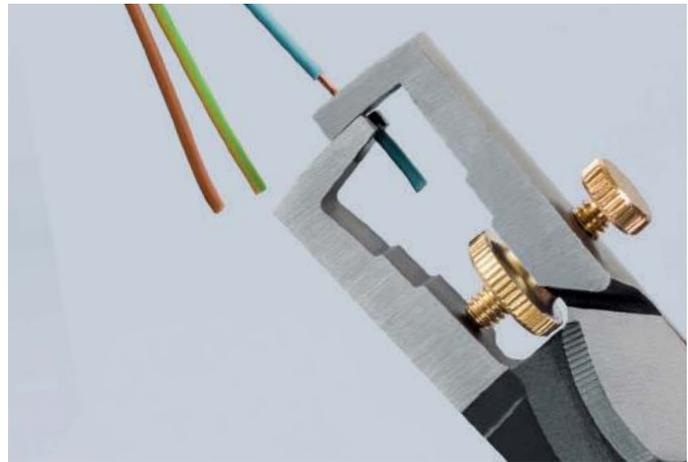

Visual length markings (steps) provide support during repeated stripping of wire in standard lengths 7/16" (11 mm) and 5/8" (16 mm)

Product Number	Packaging	↔ Inch mm	Pliers	Head	Handles	Cutting capacities		Stripping capacities		⚖ lbs
						⊕ Ø Inch Ø mm	⊕ Ø mm	AWG	Ø mm	
13 62 180		7 1/4 180	black atramentized	polished	with multi-component grips	9/16 15		8	5.0	0.44

- > multifunctional pliers for electrical installation with 6 functions; to grip flat and round material, for bending, deburring, cutting cable, stripping and crimping ferrules (end sleeves)
- > smooth surfaces near the tips grip single conductors without damaging them; serrated gripping surfaces and pipe grip for gripping flat and round material
- > clear-cut outside edge on the jaw for working on flush-mounted junction boxes and deburring feed-through holes
- > stripping holes for 12 and 14 AWG (0.75–1.5 mm² and 2.5 mm²)
- > crimp die for ferrules (end sleeves) 12–20 AWG (0.5–2.5 mm²)
- > cable shears with induction hardened precision cutting edges for copper and aluminum cables up to 19/32" dia. (5 x 2.5 mm² / dia. 5 mm)
- > slim dimensions for easy access in confined areas
- > bolted joint: precise, zero-backlash operation of pliers
- > high-grade special tool steel; forged, multi stage oil-hardened

13 82 8 T BKA*

Pliers with integrated tether attachment point for tool drop protection system

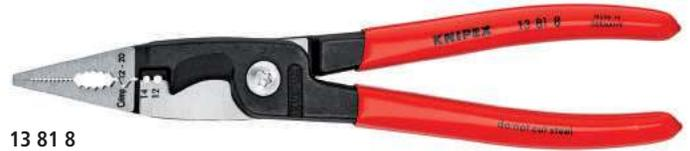
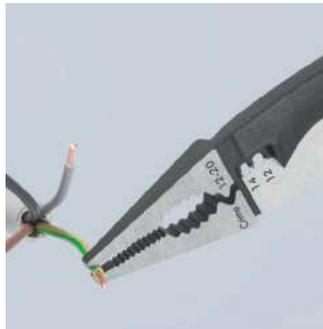

13 81 8



13 82 8



13 82 8 T BKA



13 88 8 US



Product Number	Packaging	Inch mm		Pliers	Head	Handles	Cutting capacities		Stripping capacities for cross-sections AWG	Crimping capacities AWG	lbs
							Ø Inch	AWG			
13 81 8	X	8 200		black atramentized	polished	non-slip plastic coated	9/16	0	12 and 14	12 - 20	0.52
13 82 8	X	8 200		black atramentized	polished	multi-component grips	9/16	0	12 and 14	12 - 20	0.59
13 82 8 T BKA	X	8 200		black atramentized	polished	multi-component grips	9/16	0	12 and 14	12 - 20	0.60
13 88 8 US	X	8 200		black atramentized	polished	insulated, multi-component grips, ASTM-tested	9/16	0	12 and 14	12 - 20	0.60

*Learn more about our tethered tool system on pages 207-211

Wire Stripping Tweezers – Coated

15
11

- > for stripping off varnished insulation on copper wires
- > blades for other wire diameters available as spare parts
- > tweezers body: spring steel, oil-hardened
- > plastic handles

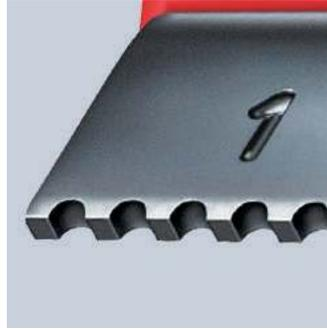

15 11 120

Product Number	Packaging	↔ Inch mm	Stripping capacities Ø Inch Ø mm	⚖️ lbs
15 11 120		4 3/4 120	1/64 0.6	0.08
15 19 005	1 pair of spare blades for 15 11 120 Ø 0.5 mm 1/64"			
15 19 006	1 pair of spare blades for 15 11 120 Ø 0.6 mm 1/64"			
15 19 008	1 pair of spare blades for 15 11 120 Ø 0.8 mm 1/32"			
15 19 010	1 pair of spare blades for 15 11 120 Ø 1.0 mm 3/64"			

Insulation Strippers

15

- > for stripping thin cables
- > accurate boring to match diameter of wire, precise stripping prism; non-adjustable
- > includes opening spring for easy repetitive work
- > chrome vanadium electric steel; forged, oil-hardened



15 51 160
MM



Product Number	Packaging	↔ Inch mm	Head	Handles	Stripping capacities Ø Inch Ø mm	⚖️ lbs
15 51 160		6 1/4 160	MM polished	non-slip plastic coated	1/64 0.5	0.24
15 61 160		6 1/4 160			1/64 0.6	0.24
15 81 160		6 1/4 160			1/32 0.8	0.24

Dismantling Tools

16
20

- > for stripping all common round cables
- > self-tightening holding lever
- > with adjusting screw for cutting depth adjustment
- > turnable blade for circular and longitudinal cutting
- > spare blade inside the handle
- > secure grip due to soft component material on handle and holding lever to avoid slipping
- > housing: plastic, impact-resistant

16 20 165 SB

With knife and hook blade, protective cap included



16 20 16 SB
⌘



16 20 165 SB
⌘

Product Number	Packaging	↔ Inch mm		Stripping capacities Ø Inch Ø mm	⚖ lbs
16 20 16 SB	X	5 1/8 130	⌘	3/16 - 5/8 4.0 - 16.0	0.17
16 20 165 SB	X	6 1/2 165		5/16 - 1 1/8 8.0 - 28.0	0.18
16 29 165	Spare blade for 16 20 16 SB / 16 20 165 SB				

Dismantling Tool

16
30

- > for dismantling round cable sheaths made of PVC, rubber, silicone or PTFE from 6.0 - 29.0 mm dia.
- > self-tightening holding lever
- > with knurled nut for cutting depth adjustment
- > changing from circular to longitudinal cutting by turning the tool body
- > spiral cutting for removing intermediate pieces
- > replaceable blade
- > housing: plastic, impact-resistant



Setting the tool for circular cutting



Longitudinal cut



16 30 135 SB
⌘



Spiral cutting

Product Number	Packaging	↔ Inch mm		Stripping capacities Ø Inch Ø mm	⚖ lbs
16 30 135 SB	X	5 1/4 133	⌘	1/4 - 1 1/8 6.0 - 29.0	0.22
16 39 135	Spare blade for 16 30 135 SB				

Dismantling Tool

16
40

- > for dismantling round cables exceeding 1" (25.0 mm) dia.
- > removes all kinds of insulation layers
- > suitable for longitudinal and circular cutting
- > cutting depth can be adjusted up to 13/64" (5.0 mm)
- > replaceable blade (both sides can be used)
- > tool body: plastic, fiberglass-reinforced



16 40 150



Adjustable cutting depth



Setting the tool for longitudinal cut



Longitudinal cut



Turning the tool for circumferential cut



Circular cut

Product Number	Packaging	↔ Inch mm	Stripping capacities Ø Inch Ø mm	⚖ lbs
16 40 150	X	6 150	>1 >25	0.36
16 49 150	Spare blade for 16 40 150			

Stripping Tool for coaxial cables

16
60

- > for stripping coaxial cables (RG 58, RG 59 and RG 62)
- > for stripping outer sheath, shield and insulation in a single process
- > with three built-in blades
- > the cutting depth of each blade can be adjusted individually with hexagonal key (Allen key)
- > the blade spacing remains constant
- > housing: plastic, impact-resistant



16 60 05 SB
MM



3 stripping steps in one operation



Interior layers uncovered individually

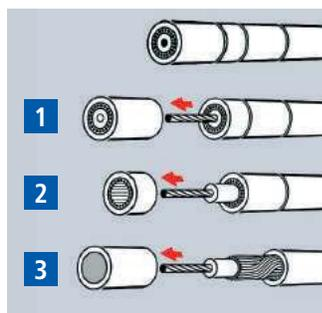

Dismantling of coaxial cable in three steps



Product Number	Packaging	↔ Inch mm		Cable type	⚖ lbs
16 60 05 SB	X	4 1/8 105	MM	RG 58, RG 59 and RG 62	0.12

Dismantling tool for data cables

16
65



- > for stripping UTP and STP data cables with diameters of 11/64" to 25/64" (4.5 to 10.0 mm)
- > stripping device for 0.2 / 0.3 / 0.8 / 1.5 / 2.5 / 4.0 mm²
- > double shell, folding back stripping tool
- > with opening spring and locking lever
- > clip for safe transport
- > body: plastic, fiberglass-reinforced
- > blades: special tool steel; oil-hardened, TiN-coated

16 65 125 SB
M



Product Number	Packaging	↔ Inch mm		Cable type	Stripping capacities Ø Inch Ø mm	Stripping capacities mm ²	⚖ lbs
16 65 125 SB	X	5 125	M	CAT 5, CAT 6, CAT 7, Twisted-Pair (UTP/STP)	11/16 - 25/64 4.5 - 10.0	0.2 - 4.0	0.11

Universal Dismantling Tools

16
8

- > for dismantling and stripping all common round and damp-proof installation cables between 3 x 1.5 mm² up to 5 x 2.5 mm²
- > for use in conduit and distribution boxes
- > double shell, folding back stripping tool
- > with opening spring and locking lever
- > clip for safe transport
- > body: plastic, fiberglass-reinforced

16 85 125 SB

With additional blade for longitudinal cuts; telescopic blade inside; stripping device for 0.2 / 0.3 / 0.8 / 1.5 / 2.5 / 4.0 mm²; with integrated cable guide for longitudinal cut. This enables rigid insulation (e.g. halogen-free) to be stripped easily



16 80 125 SB
M



16 85 125 SB
M



Product Number	Packaging	↔ Inch mm		Stripping capacities Ø mm	Stripping capacities mm ²	Cable type	⚖ lbs
16 80 125 SB	X	5 125	M	8.0 - 13.0		round cable. e.g.: 3 x 1.5 mm ² up to 5 x 2.5 mm ²	0.12
16 85 125 SB	X	5 125	M	8.0 - 13.0	0.2 - 4.0	round cable. e.g.: 3 x 1.5 mm ² up to 5 x 2.5 mm ²	0.1

KNIPEX ErgoStrip® Universal Dismantling Tool

16
95

For fast and precise dismantling and stripping of all common round and damp-proof installation cables (e.g. NYM cable 3 x 1.5 mm² up to 5 x 2.5 mm²), data cable and coax cable.

Innovative, ergonomic pistol grip design for easy cutting, stripping and longitudinal cutting of the sheath.

- > conical, slim tool ends for better access in confined areas
- > stripping holes for 0.2 / 0.3 / 0.8 / 1.5 / 2.5 / 4 mm²
- > location ridges between stripping holes make for easy alignment of wire
- > opening spring and locking device make the tool easy to open and secure
- > easy insertion of coax and data cable
- > multi-component design with a soft plastic zone for comfortable use and a secure grip
- > housing: plastic, fiberglass-reinforced



16 95 01 SB
version for right-handers

PAT. PEND.

16 95 02 SB
version for left-handers

16 95 02 SB
ErgoStrip® L for left-handers



Stripping of NYM cable



Concealed cutting blade for stripping the outside cable sheath



Stripping single conductor wire



Stripping data cable



Stripping coax cable sheath



Stripping the internal portion of the coax cable

Product Number	Packaging	↔ Inch mm	Version		Wire stripping for round cable Ø mm	Wire stripping for conductors and strands mm ²	Wire stripping for data cable	Wire stripping for coax cable Ø mm	⚖ lbs
16 95 01 SB	X	5 1/4 135	Right-handed	MM	8 - 13	0.2 - 4.0	CAT 5 - 7 Twisted pair (UTP/STP)	4.8 - 7.5	0.21
16 95 02 SB	X	5 1/4 135	Left-handed	MM	8 - 13	0.2 - 4.0	CAT 5 - 7 Twisted pair (UTP/STP)	4.8 - 7.5	0.21

Round pliers

with cutting edge

Jewelers Pliers, DIN ISO 5743

19

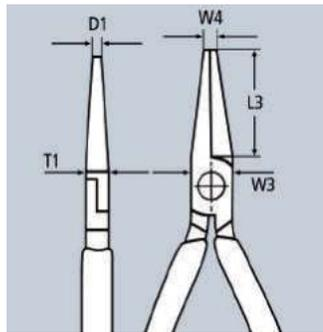
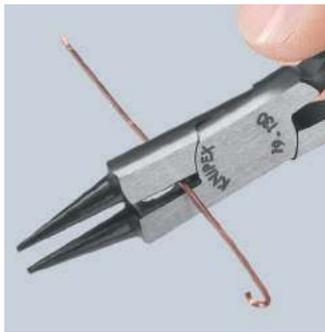

- > for fine wire and working with jewelry
- > ideal for cutting and bending work, also in electronics
- > bending wire loops
- > precision ground round jaws with fine, pointed tips
- > cutting edges induction hardened (approx. 60 HRC)
- > vanadium steel; forged, multi stage oil-hardened



19 01 130
8

Product Number	Packaging	↔ Inch mm	Pliers	Head	Handles	Cutting capacities		Dimensions					⚖ lbs	
						Ø Inch Ø mm	Ø Inch Ø mm	D1 Inch mm	L3 Inch mm	T1 Inch mm	W3 Inch mm	W4 Inch mm		
19 01 130		5 1/4 130	8	black atramentized	polished	non-slip plastic coated	3/32 2.2	1/16 1.6	3/64 1.0	1 1/4 32.0	5/16 8.0	17/32 13.5	5/64 2.0	0.16

Flat Nose Pliers

DIN ISO 5745

20

- > flat, short, wide jaws
- > knurled gripping surfaces
- > special tool steel; forged, oil-hardened

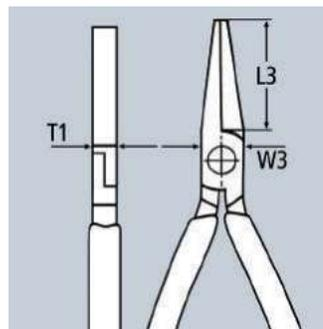

20 01 160



20 02 160



20 06 160
⚠ 1000 V

Product Number	Packaging	↔ Inch mm	Pliers	Head	Handles	Dimensions			⚖ lbs	
						L3 Inch mm	W3 Inch mm	T1 Inch mm		
20 01 125		5 125				1 1/16 27.0	37/64 14.5	5/16 8.0	0.18	
20 01 140		5 1/2 140		black atramentized	polished	non-slip plastic coated	1 7/64 28.0	39/64 15.5	3/8 9.5	0.24
20 01 160		6 1/4 160		black atramentized	polished	non-slip plastic coated	1 3/16 30.0	43/64 17.0	3/8 9.5	0.32
20 01 180		7 1/4 180					1 3/8 35.0	3/4 19.0	25/64 10.0	0.41
20 02 140		6 1/4 140		black atramentized	polished	multi-component grips	1 3/32 28.0	39/64 15.5	3/8 9.5	0.30
20 02 160		6 1/4 160		black atramentized	polished	multi-component grips	1 3/16 30.0	43/64 17.0	3/8 9.5	0.38
20 06 160		6 1/2 165	⚠ 1000 V	chrome plated	polished	insulated, multi-component grips, VDE-tested	1 3/16 30.0	43/64 17.0	3/8 9.5	0.41

Round Nose Pliers

DIN ISO 5745

22

- > for bending wire loops
- > round, short jaws; smooth ground
- > smooth tips
- > special tool steel; forged, oil-hardened

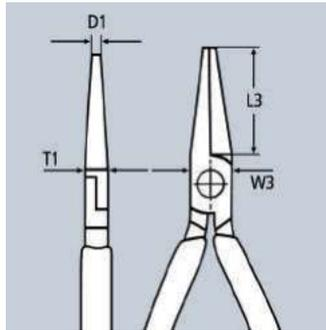

22 01 160
8



22 02 160
8



22 08 160 SBA
⚡ 1000 V ASTM 8

Product Number	Packaging	↔ Inch mm		Pliers	Head	Handles	Dimensions				⚖ lbs
							L3 Inch mm	W3 Inch mm	D1 Inch mm	T1 Inch mm	
22 01 125		5 125					1 1/16 27.0	37/64 14.5	5/64 2.0	5/16 8.0	0.16
22 01 140		5 1/2 140	8	black atramentized	polished	non-slip plastic coated	1 7/64 28.0	21/32 16.5	3/32 2.5	3/8 9.5	0.22
22 01 160	X	6 1/4 160					1 3/16 30.0	45/64 18.0	1/8 3.0	3/8 9.5	0.30
22 02 140		5 1/2 140	8	black atramentized	polished	multi-component grips	1 7/64 28.0	21/32 16.5	3/32 2.5	3/8 9.5	0.29
22 02 160		6 1/4 160	8				1 3/16 30.0	45/64 18.0	1/8 3.0	3/8 9.5	0.37
22 08 160 SBA	X	6 1/4 160	⚡ 1000 V ASTM 8	black atramentized	polished	insulated with multi-component grips, ASTM-tested	1 3/16 30.0	45/64 18.0	1/8 3.0	3/8 9.5	0.40

Flat Nose Pliers with cutting edges

Precision Mechanics Pliers

DIN ISO 5745

23

- > suitable for gripping and cutting work in fine mechanics
- > flat, long and tapered jaws
- > cutting edge hardness (approx. 60 HRC)
- > high-grade special tool steel; forged, multi stage oil-hardened

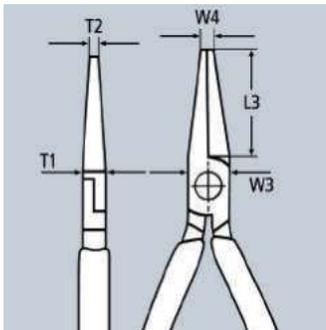

23 01 140

Product Number	Packaging	↔ Inch mm		Head	Handles	Cutting capacities		Dimensions					⚖ lbs
						Ø Inch Ø mm	Ø Inch Ø mm	T1 Inch mm	L3 Inch mm	W3 Inch mm	W4 Inch mm	T2 Inch mm	
23 01 140		5 1/2 140		polished	plastic coated	3/32 2.5	1/16 1.6	9/32 7.0	1 3/8 35.0	31/64 12.5	1/8 3.0	11/64 4.5	0.17

Snipe Nose Side Cutting Pliers

Radio Pliers, DIN ISO 5745

25

- > suitable for fine gripping and cutting work
- > pointed, half-round jaws
- > serrated gripping surfaces
- > cutting edges for soft, medium hard and hard wire
- > cutting edges induction hardened, cutting edge hardness (approx. 61 HRC)
- > vanadium steel; forged, multi-stage oil-hardened

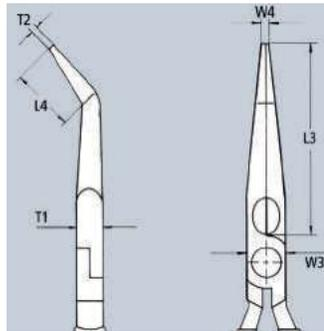
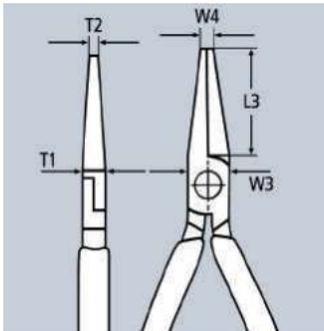

25 01 160



25 02 160

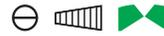

25 08 160 SBA



25 21 160



Product Number	Packaging	↔ Inch mm		Pliers	Head	Handles	Cutting capacities				Dimensions				⚖ lbs
							● Ø Inch Ø mm	● Ø Inch Ø mm	L3 Inch mm	L4 Inch mm	W3 Inch mm	T1 Inch mm	W4 Inch mm	T2 Inch mm	
25 01 125		5 125					3/32 2.2	1/16 1.6	1 1/16 27.0	-	1/2 13.0	9/32 7.0	3/32 2.5	5/64 1.8	0.16
25 01 140		5 1/2 140	☉	black atramentized	polished	plastic coated	3/32 2.5	1/16 1.6	1 21/32 42.0	-	19/32 15.0	5/16 8.0	3/32 2.5	5/64 2.0	0.20
25 01 160	X	6 1/4 160					3/32 2.5	1/16 1.6	1 31/32 50.0	-	21/32 16.5	23/64 9.0	1/8 3.0	3/32 2.5	0.25
25 02 140	X	5 1/2 140	☉	black atramentized	polished	multi- component grips	3/32 2.5	1/16 1.6	1 21/32 42.0	-	19/32 15.0	5/16 8.0	3/32 2.5	5/64 2.0	0.24
25 02 160	X	6 1/4 160	☉	black atramentized	polished	multi- component grips	3/32 2.5	1/16 1.6	1 31/32 50.0	-	21/32 16.5	23/64 9.0	1/8 3.0	3/32 2.5	0.32
25 08 160 SBA	X	6 1/4 160	⚡ 1000V ASTM ☉	black atramentized	polished	insulated, multi- component grips, ASTM-tested	3/32 2.5	1/16 1.6	1 31/32 50.0	-	21/32 16.5	23/64 9.0	1/8 3.0	3/32 2.5	0.34
25 21 160	X	6 1/4 160	∠40° ☉	black atramentized	polished	plastic coated	3/32 2.5	1/16 1.6	1 31/32 50.0	29/32 23.0	21/32 16.5	23/64 9.0	1/8 3.0	3/32 2.5	0.25

Snipe Nose Side Cutting Pliers

Stork Beak Pliers, DIN ISO 5745

26

Elastic tips: stable even when twisted

- > distortion-tolerant, flexible precision tips
- > half-round, long, pointed jaws
- > hardened cutting edges (approx. 61 HRC) for soft, medium hard and hard wire
- > vanadium steel; forged, multi-stage oil-hardened

26 11 200 S1

Integrated stripping hole in cutting blade. Strips 12 AWG wire

26 12 200 T BKA / 26 22 200 T BKA*

Pliers with integrated tether attachment point for tool drop protection system

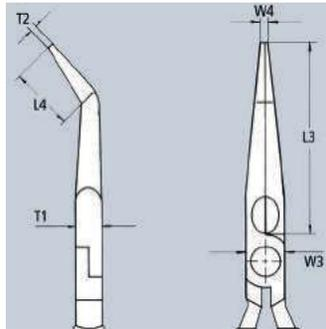
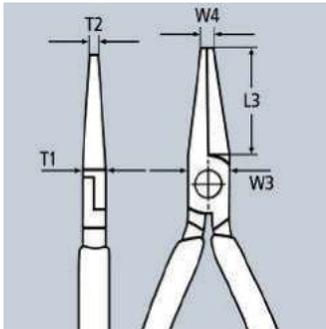
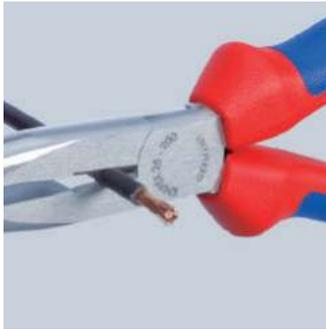

26 11 200

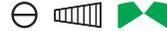

26 12 200



26 12 200 T BKA

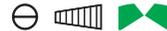

26 22 200

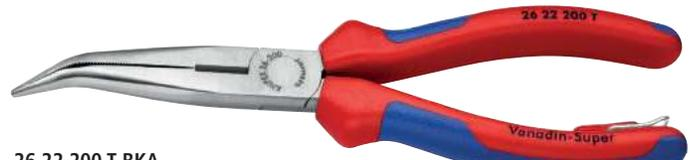

26 22 200 T BKA



Product Number	Packaging	↔ Inch mm	Icon	Pliers	Head	Handles	Cutting capacities		Dimensions							⚖ lbs
							Ø Inch Ø mm	Ø Inch Ø mm	L3 Inch mm	L4 Inch mm	T1 Inch mm	W3 Inch mm	W4 Inch mm	T2 Inch mm		
26 11 200	X	8 200		black atramentized	polished	plastic coated	1/8 3.2	3/32 2.2	2 7/8 73.0	-	3/8 9.5	45/64 18.0	1/8 3.0	3/32 2.5	0.38	
26 11 200 S1	X	8 200	⊖	black atramentized	polished	plastic coated	1/8 3.2	3/32 2.2	2 7/8 73.0	-	3/8 9.5	45/64 18.0	1/8 3.0	3/32 2.5	0.38	
26 12 200	X	8 200	⊖	black atramentized	polished	multi-component grips	1/8 3.2	3/32 2.2	2 7/8 73.0	-	3/8 9.5	45/64 18.0	1/8 3.0	3/32 2.5	0.44	
26 12 200 T BKA	X	8 200	⊖	black atramentized	polished	multi-component grips, integrated tether attachment point	1/8 3.2	3/32 2.2	2 7/8 73.0	-	3/8 9.5	45/64 18.0	1/8 3.0	3/32 2.5	0.45	
26 21 200	X	8 200	∠40° ⊖	black atramentized	polished	plastic coated	1/8 3.2	3/32 2.2	2 7/8 73.0	29/32 23.0	3/8 9.5	45/64 18.0	1/8 3.0	3/32 2.5	0.38	
26 22 200	X	8 200	∠40° ⊖	black atramentized	polished	multi-component grips	1/8 3.2	3/32 2.2	2 7/8 73.0	29/32 23.0	3/8 9.5	45/64 18.0	1/8 3.0	3/32 2.5	0.43	
26 22 200 T BKA	X	8 200	∠40° ⊖	black atramentized	polished	multi-component grips, integrated tether attachment point	1/8 3.2	3/32 2.2	2 7/8 73.0	29/32 23.0	3/8 9.5	45/64 18.0	1/8 3.0	3/32 2.5	0.45	

Snipe Nose Side Cutting Pliers

Stork Beak Pliers

DIN ISO 5745 IEC 60900 DIN EN 60900

26

- > distortion-tolerant, flexible precision tips
- > half-round, long, pointed jaws
- > hardened cutting edges (approx. 61 HRC) for soft, medium hard and hard wire
- > vanadium steel; forged, multi-stage oil-hardened

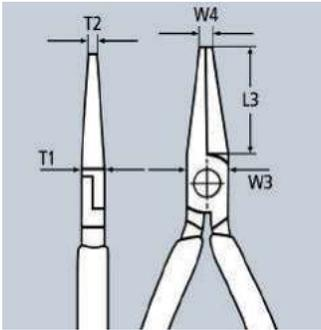

26 18 200 US

⚡ 1000V ASTM ⊖



26 28 200 SBA

∠40° ⚡ 1000V ASTM ⊖

Product Number	Packaging	↔ Inch mm		Pliers	Head	Handles	Cutting capacities		Dimensions						⚖ lbs
							⊙ Ø Inch Ø mm	⊙ Ø Inch Ø mm	L3 Inch mm	T1 Inch mm	W3 Inch mm	W4 Inch mm	T2 Inch mm		
26 18 200 US	X	8 200	⚡ 1000V ASTM ⊖	black atramentized	polished	insulated, multi-component handles, ASTM-tested	1/8 3.2	3/32 2.2	2 7/8 73.0	3/8 9.5	45/64 18.0	1/8 3.0	3/32 2.5	0.45	
26 28 200 SBA	X	8 200	∠40° ⚡ 1000V ASTM ⊖	black atramentized	polished	insulated, multi-component handles, ASTM-tested	1/8 3.2	3/32 2.2	2 7/8 73.0	3/8 9.5	45/64 18.0	1/8 3.0	3/32 2.5	0.46	



Snipe Nose Pliers with Center Cutter

Telephone Pliers

DIN ISO 5743

27

- > grips and separates single wires in harnesses
- > center cutter for soft wire
- > half-round jaws
- > serrated gripping surfaces
- > chrome vanadium electric steel; forged, oil-hardened

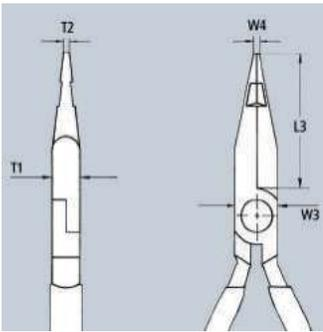

27 01 160



Product Number	Packaging	↔ Inch mm	Head	Handles	Dimensions					⚖ lbs	
					L3 Inch mm	W3 Inch mm	T1 Inch mm	W4 Inch mm	T2 Inch mm		
27 01 160		6 1/4 160	⊖	polished	plastic coated	1 27/32 47.0	21/32 16.5	3/8 9.5	1/8 3.0	5/64 2.0	0.27

Long Reach Needle Nose Pliers

DIN ISO 5743

28

- > suitable for gripping and assembly work
- > serrated gripping surfaces
- > high-grade special tool steel; forged, oil-hardened

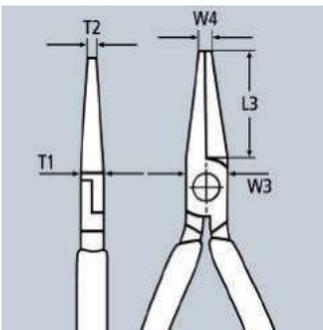

28 01 200



28 21 200



Product Number	Packaging	↔ Inch mm	Pliers	Head	Handles	Dimensions					⚖ lbs	
						L3 Inch mm	W3 Inch mm	T1 Inch mm	W4 Inch mm	T2 Inch mm		
28 01 200		8 200	⊖	black atramentized	polished	plastic coated	1 19/64 33.0	17/32 13.5	13/32 10.5	5/32 4.0	13/32 10.5	0.43
28 21 200		8 200	⊖	black atramentized	polished	plastic coated	1 11/32 34.0	17/32 13.5	13/32 10.5	1/8 3.0	1/8 3.0	0.41

Long Reach Needle Nose Pliers

with transverse wave

DIN ISO 9745

28

Long assembly pliers with wave profile

Long slim design is perfect for gripping and assembly work in hard to reach areas

Deep parts can be easily reached using the slim, half-round tips

Grips up to 2 1/4"

- > careful yet reliable gripping, holding and guiding of small copper pipes, screws and cables as well as other round parts due to milled grooves with smooth surfaces
- > four small pulling grooves in jaws will grab tightly when holding and pulling round objects
- > serrated gripping area for holding on to round parts near base of jaws
- > particularly suitable for work in the automotive trade and in mechanical engineering
- > slim yet robust tool
- > forged from special tool steel; oil-hardened and tempered



28 71 280



28 81 280
 $\angle 45^\circ$

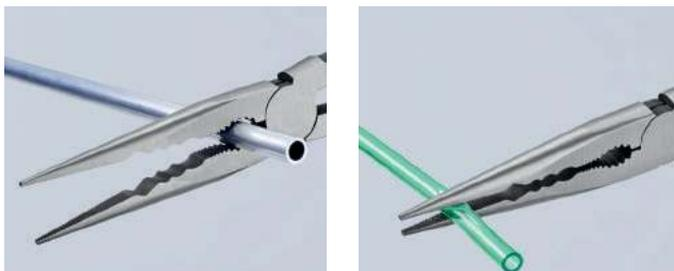
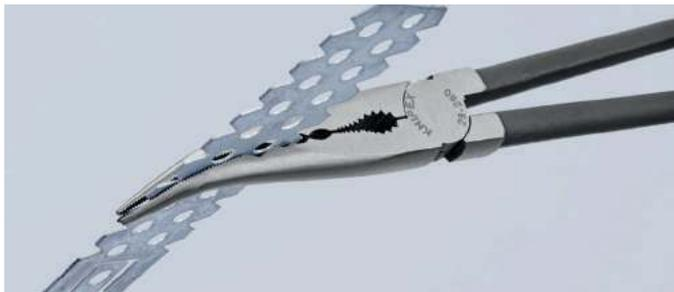
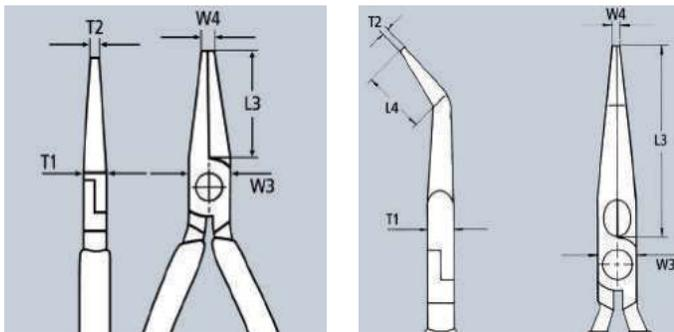

Transverse wave shape gripping profile for gripping, holding and guiding

Product Number	Packaging	↔ Inch mm		Pliers	Head	Handles	Dimensions						 lbs
							L3 Inch mm	L4 Inch mm	W3 Inch mm	T1 Inch mm	W4 Inch mm	T2 Inch mm	
28 71 280	X	11 280		black atramentized	polished	non-slip plastic coated	3 76.5	-	25/32 20.0	23/64 9.0	1/8 3.0	3/32 2.5	0.52
28 81 280	X	11 280	$\angle 45^\circ$	black atramentized	polished	non-slip plastic coated	2 3/4 70.0	25/32 20.0	25/32 20.0	23/64 9.0	3/32 2.5	3/32 2.5	0.52



Telephone Pliers

DIN ISO 5745

29

- > cross-hatched gripping surfaces, knurled
- > chrome vanadium electric steel; forged, oil-hardened

29 21 160

Extra slim fine tips; suitable for soldering work

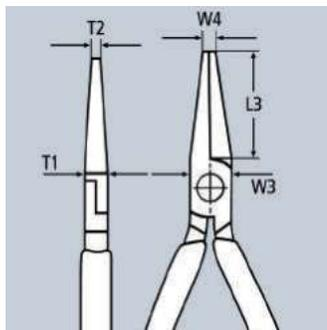

29 11 160



29 21 160



Product Number	Packaging	↔ Inch mm	Pliers	Head	Handles	Dimensions					⚖ lbs	
						L3 Inch mm	W3 Inch mm	T1 Inch mm	W4 Inch mm	T2 Inch mm		
29 11 160		6 1/4 160		black atramentized	polished	plastic coated	2 11/64 55.0	35/64 14.0	5/16 8.0	3/32 2.5	21/64 8.5	0.23
29 21 160		6 1/4 160		black atramentized	polished	plastic coated	2 1/8 54.0	35/64 14.0	23/64 9.0	5/64 2.0	5/64 2.0	0.25

Long Nose Pliers

DIN ISO 5745

30

- > heavy-duty gripping pliers
- > different jaw styles for a wide range of applications
- > chrome vanadium electric steel; forged, oil-hardened

Style 1

Long, trapezoidal jaws; serrated gripping surfaces

Style 2

Long, half-round jaws; serrated gripping surfaces

Style 3

Long, round jaws; smooth gripping surfaces

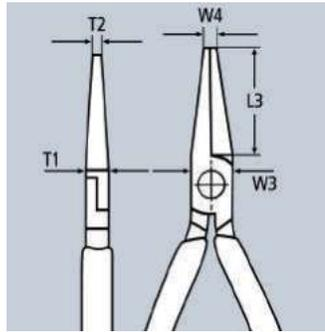

30 11 160



30 21 160



30 36 160



Product Number	Packaging	↔ Inch mm		Pliers	Head	Handles	Style	Dimensions					⚖ lbs
								L3 Inch mm	W3 Inch mm	T1 Inch mm	W4 Inch mm	T2 Inch mm	
30 11 140		5 1/2 140					1	1 21/32 42.0	19/32 15.0	5/16 8.0	3/32 2.5	5/32 4.0	0.19
30 11 160		6 1/4 160		black atramentized	polished	plastic coated	1	1 53/64 46.5	21/32 16.5	3/8 9.5	1/8 3.0	13/64 5.0	0.27
30 11 190		7 1/2 190					1	1 31/32 50.0	47/64 18.5	3/8 9.5	1/8 3.0	9/32 7.0	0.31
30 16 160		6 1/4 160		chrome plated	chrome plated	insulated, multi-component grips, VDE-tested	1	1 53/64 46.5	21/32 16.5	3/8 9.5	1/8 3.0	13/64 5.0	0.33
30 21 140		5 1/2 140					2	1 21/32 42.0	19/32 15.0	5/16 8.0	3/32 2.5	5/64 2.0	0.21
30 21 160		6 1/4 160		black atramentized	polished	plastic coated	2	1 31/32 50.0	21/32 16.5	3/8 9.5	1/8 3.0	3/32 2.5	0.27
30 21 190		7 1/2 190					2	1 31/32 50.0	47/64 18.5	5/16 8.0	1/8 3.0	3/32 2.4	0.30
30 31 160		6 1/4 160		black atramentized	polished	plastic coated	3	1 19/32 41.0	21/32 16.5	3/8 9.5	13/64 5.0	3/32 2.5	0.24
30 36 160		6 1/4 160		chrome plated	chrome plated	insulated, multi-component grips, VDE-tested	3	1 19/32 41.0	21/32 16.5	3/8 9.5	13/64 5.0	3/32 2.5	0.31

Halogen Bulb Exchange Pliers

30
41

- > for the installation of wedge bulb lamps
- > plastic coated gripping surfaces
- > chrome vanadium electric steel; forged, oil-hardened



30 41 160



Product Number	Packaging	↔ Inch mm		Pliers	Head	Handles	⚖ lbs
30 41 160		6 1/4 160		black atramentized	polished	plastic coated	0.29

Gripping Pliers

Needle Nose Pliers, DIN ISO 5743

31

- > precision pliers for assembly, bending and adjusting work
- > with extra-long jaws: length of jaws 2 11/64" (55.0 mm)
- > smooth gripping surfaces and edges
- > chrome vanadium electric steel; forged, oil-hardened

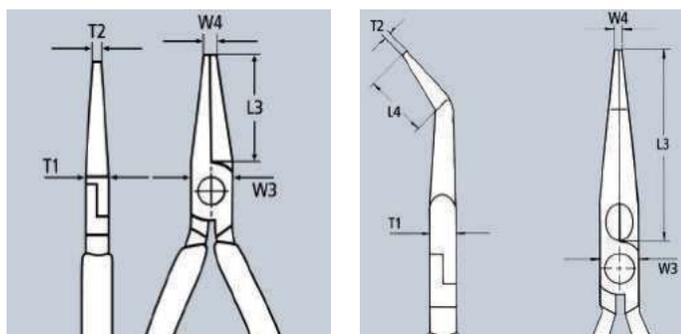

31 11 160



31 21 160

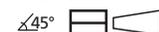

Product Number	Packaging	↔ Inch mm		Pliers	Head	Handles	Dimensions						⚖ lbs
							L3 Inch mm	L4 Inch mm	W3 Inch mm	T1 Inch mm	W4 Inch mm	T2 Inch mm	
31 11 160		6 1/4 160		black atramentized	polished	plastic coated	2 11/64 55.0	-	5/8 16.0	19/64 7.5	5/64 1.8	3/32 2.5	0.22
31 21 160		6 1/4 160	∠45°	black atramentized	polished	plastic coated	2 11/64 55.0	1 1/16 27.0	5/8 16.0	19/64 7.5	5/64 1.8	3/32 2.5	0.21

Relay Adjusting Pliers

DIN ISO 5743

32

- > perfect for gripping small wires and bending contact and relay springs
- > polished gripping surfaces
- > smooth edges
- > high-grade special tool steel; forged, oil-hardened

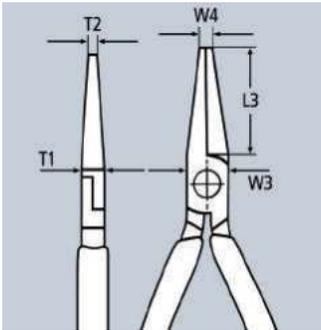

32 11 135



32 21 135



32 31 135



Product Number	Packaging	↔ Inch mm	Pliers	Head	Handles	Dimensions					⚖ lbs	
						L3 Inch mm	W3 Inch mm	T1 Inch mm	W4 Inch mm	T2 Inch mm		
32 11 135		5 1/4 135		black atramentized	polished	plastic coated	1 11/32 34.0	31/64 12.5	9/32 7.0	1/16 1.4	1/16 1.5	0.17
32 21 135		5 1/4 135		black atramentized	polished	plastic coated	1 11/32 34.0	31/64 12.5	9/32 7.0	1/16 1.4	9/64 3.5	0.16
32 31 135		5 1/4 135		black atramentized	polished	plastic coated	1 1/4 32.0	31/64 12.5	9/32 7.0	1/16 1.4	9/64 3.5	0.16

Duckbill Pliers

DIN ISO 5743

33

- > duckbill shaped jaws 23/64" (9.0 mm) wide at the tip and tapering to 1/16" (1.5 mm) thickness
- > smooth gripping surfaces
- > chrome vanadium electric steel; forged, oil-hardened

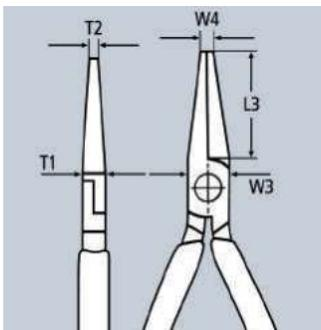

33 01 160



Product Number	Packaging	↔ Inch mm	Pliers	Head	Handles	Dimensions					⚖ lbs	
						L3 Inch mm	W3 Inch mm	T1 Inch mm	W4 Inch mm	T2 Inch mm		
33 01 160	X	6 1/4 160		black atramentized	polished	plastic coated	2 11/64 55.0	19/32 15.0	19/64 7.5	1/8 3.0	23/64 9.0	0.23

The Subtle Difference

KNIPEX precision electronics pliers are made of high-quality ball bearing steel and processed with the highest degree of care. Each opening movement is gentle and even without backlash. Each work step proceeds reliably and precisely. This makes work much easier for professionals.



Which Electronics Pliers is right for you?

KNIPEX has a full line of gripping and cutting electronics pliers. They are available in a variety of jaw types, joint and head styles, bevel types and can have additional features to make working with our products simple and easy

The gripping line is available in multiple jaw types and gripping surfaces, giving you options for choosing the pliers suited for your work. The cutting line is more expansive and has multiple products lines and pliers available to find the one best fit for you.



Joint Type	
Box joint, bolted and rivet	
Box joint	
Bolted joint	
Rivet joint	

Head Type	
Oval, tapered and end cutting	
Oval head	
Tapered head	
End cutting head	

Joint Type

There are three joint types available: Box joint, Bolted joint and Rivet joint.

- > Box joint is used in some of our most popular product lines including our water pump pliers and is proven for precision and durability with its high torsion resistance.
- > Bolted joint provides the most precision and a permanently even cutting movement making it a perfect fit for repetitive type applications.
- > Rivet joint offers the most economical pick of the joint types.

Head Type

There are three head styles available in our cutting pliers: Oval, Tapered and End Cutting.

- > Oval style is the most durable due to the additional material close to the cutting edges.
- > Tapered has a narrowed head which allows for easier access into tight places.
- > End Cutting head style is best for hard-to reach areas and for working on components from above.

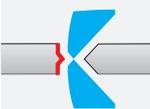
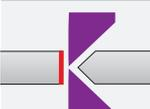
Bevel/Cutting Edge Type			
Semi-flush, flush and super (ultra) flush			
	with bevel (outside bevel)		semi-flush
	with small bevel (outside bevel)		semi-flush
	with very small bevel (outside bevel)		semi-flush
	without bevel (outside bevel)		flush
	flush cut		ultra or super flush

Bevel Type

A bevel is a sloping surface on the outer side of the cutting edge.

- > A small bevel leads to an easier and more flush cut while the risk of damaging the cutting edges rises (overloading).
- > A larger bevel allows hard materials to be cut without the risk of damage to the cutting edges.
- > Depending on the size of the bevel, you will get either a semi-flush, flush or ultra-flush cut finish. The choice of bevel depends on the material being cut and the desired flush cut end result. A flush cutting edge is only suitable for soft materials such as copper or plastics.

Handle Type

Our four handle styles are plastic dipped, single-component, multi-component and ESD.

- > ESD stands for Electrostatic Discharge. The handles themselves discharge electrostatic energy in a gradual and controlled manner to protect electrical components.
- > Plastic dipped is our most basic handle and is easy to maintain and clean of oils and residues.
- > Our component handles offer comfort and ease of use making them great for repetitive work where comfort is a key need.

Additional Features

Other features include lead catcher, double springs and carbide cutting edges.

Handle Type			
KNIPEX has multiple handle styles available (plastic dipped, single-component, multi-component, etc.) that can be broken down into two main categories for electronic pliers - ESD or Non-ESD			
	Non-ESD	ESD	
Plastic Dipped			
Single-component			
Multi-component			

ESD pliers	
Semi-flush, flush and super (ultra) flush	
<ul style="list-style-type: none"> > Electrostatic energy is discharged through the handles in a gradual and controlled manner > ESD handles protect electrical components from electrostatic discharge > KNIPEX ESD handles are in accordance with applicable standards <ul style="list-style-type: none"> > IEC TR 61 340-5 > DIN EN 61 340-5 > SP Method 2472 	

- > for very precise assembly work, e.g. in electronics and fine mechanics
- > for gripping, holding and bending
- > smoothly ground gripping surfaces
- > approx. 20% lighter than conventional electronics pliers
- > bolted joint and carefully manufactured joint surfaces for even, low-friction movement throughout the entire opening range
- > double spring for a gentle and even opening
- > ergonomically optimized handles
- > ball bearing chrome steel; forged, manifold oil-hardened

- Style 1**
Flat, wide jaws
- Style 2**
Half-round jaws
- Style 3**
Round, pointed jaws

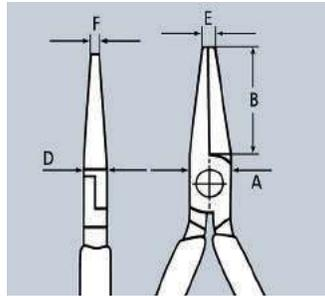

34 12 130



34 22 130 ESD



34 32 130

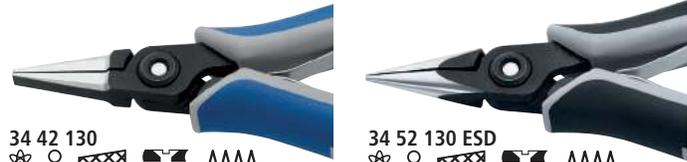

34 42 130



34 52 130 ESD

ESD pliers (electrostatic discharge)

Electrostatic energy is discharged through the handles in a gradual and controlled manner which protects components endangered by electrostatic discharge in accordance with applicable standards, e.g. IEC TR 61 340-5, DIN EN 61 340-5, SP Method 2472



Product Number	Packaging	↔ Inch mm	Head	Handles	Style	Dimensions					⚖ lbs	
						A Inch mm	B Inch mm	D Inch mm	E Inch mm	F Inch mm		
34 12 130		5 1/4 130		polished	multi-component grips	1	7/16 11.2	55/64 21.9	1/4 6.5	1/16 1.4	9/64 3.5	0.14
34 12 130 ESD		5 1/4 130		polished	ESD multi-component grips	1	7/16 11.2	55/64 21.9	1/4 6.5	1/16 1.4	9/64 3.5	0.14
34 22 130		5 1/4 130		polished	multi-component grips	2	7/16 11.2	57/64 22.7	1/4 6.5	1/16 1.6	1/16 1.6	0.14
34 22 130 ESD		5 1/4 130		polished	ESD multi-component grips	2	7/16 11.2	57/64 22.7	1/4 6.5	1/16 1.6	1/16 1.6	0.14
34 32 130		5 1/4 130		polished	multi-component grips	3	7/16 11.2	15/16 23.7	1/4 6.5	5/64 2.0	3/64 1.0	0.14
34 32 130 ESD		5 1/4 130		polished	ESD multi-component grips	3	7/16 11.2	15/16 23.7	1/4 6.5	5/64 2.0	3/64 1.0	0.14
34 42 130		5 1/4 130		polished	multi-component grips	4	7/16 11.2	55/64 21.9	1/4 6.5	1/16 1.6	9/64 3.5	0.14
34 42 130 ESD		5 1/4 130		polished	ESD multi-component grips	4	7/16 11.2	55/64 21.9	1/4 6.5	1/16 1.6	9/64 3.5	0.14
34 52 130		5 1/4 130		polished	multi-component grips	5	7/16 11.2	55/64 21.9	1/4 6.5	1/16 1.6	1/16 1.6	0.14
34 52 130 ESD		5 1/4 130		polished	ESD multi-component grips	5	7/16 11.2	55/64 21.9	1/4 6.5	1/16 1.6	1/16 1.6	0.14

Electronics Pliers

DIN ISO 9655

35

- > precision pliers for ultra fine assembly work in electronics and fine mechanics
- > designed for gripping, holding and bending small components
- > sturdy, zero backlash
- > smooth gripping surfaces and rounded edges prevent damage to components
- > low-friction double spring for gentle and even opening
- > the mirror polish, together with a fine film of oil, offer effective rust protection – no circuit faults caused by peeling chrome from plated tools
- > ball bearing chrome steel

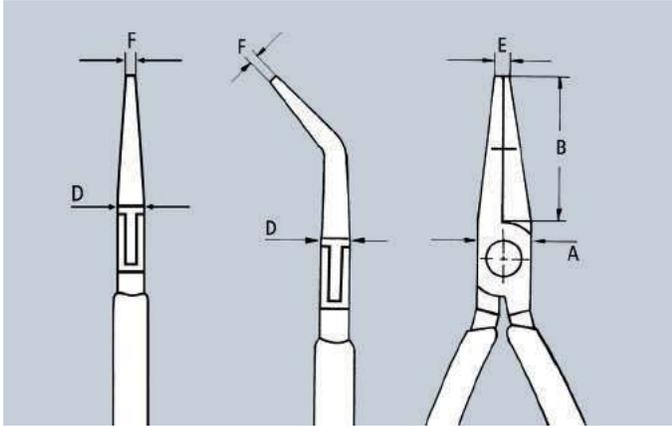

Product Number	Packaging	↔ Inch mm	✳️ ◻ ◁ ◻ ◻ ◻	Head	Handles	Dimensions					⚖️ lbs
						A Inch mm	B Inch mm	D Inch mm	E Inch mm	F Inch mm	
35 11 115		4 1/2 115	✳️ ◻ ◁ ◻ ◻ ◻	mirror polished	slim plastic grips	3/8 9.5	57/64 22.5	17/64 6.7	5/64 2.0	5/32 4.0	0.13
35 12 115	X	4 1/2 115	✳️ ◻ ◁ ◻ ◻ ◻	mirror polished	multi-component grips	3/8 9.5	57/64 22.5	17/64 6.7	5/64 2.0	5/32 4.0	0.16
35 21 115		4 1/2 115	✳️ ⊖ ◁ ◻ ◻ ◻	mirror polished	slim plastic grips	3/8 9.5	57/64 22.5	17/64 6.7	5/64 2.0	1/16 1.5	0.13
35 22 115		4 1/2 115	✳️ ⊖ ◁ ◻ ◻ ◻	mirror polished	multi-component grips	3/8 9.5	57/64 22.5	17/64 6.7	5/64 2.0	1/16 1.5	0.16
35 31 115		4 1/2 115	✳️ 8 ◁ ◻ ◻ ◻	mirror polished	slim plastic grips	3/8 9.5	57/64 22.5	17/64 6.7	5/64 2.0	3/64 1.0	0.13
35 32 115		4 1/2 115	✳️ 8 ◁ ◻ ◻ ◻	mirror polished	multi-component grips	3/8 9.5	57/64 22.5	17/64 6.7	5/64 2.0	3/64 1.0	0.16
35 41 115		4 1/2 115	✳️ 45° ⊖ ◁ ◻ ◻ ◻	mirror polished	single-component grips	3/8 9.5	57/64 22.5	17/64 6.7	5/64 2.0	1/16 1.5	0.16
35 42 115		4 1/2 115	✳️ 45° ⊖ ◁ ◻ ◻ ◻	mirror polished	multi-component grips	3/8 9.5	57/64 22.5	17/64 6.7	5/64 2.0	1/16 1.5	0.16
35 52 145		5 3/4 145	✳️ ◻ ◁ ◻ ◻ ◻	mirror polished	multi-component grips	15/32 12.0	1 37/64 40.0	19/64 7.5	1/16 1.5	5/32 4.0	0.23
35 62 145		5 3/4 145	✳️ ⊖ ◁ ◻ ◻ ◻	mirror polished	multi-component grips	15/32 12.0	1 37/64 40.0	19/64 7.5	3/32 2.5	1/16 1.5	0.23
35 72 145		5 3/4 145	✳️ 8 ◁ ◻ ◻ ◻	mirror polished	multi-component grips	15/32 12.0	1 37/64 40.0	19/64 7.5	3/32 2.5	3/64 1.3	0.23
35 82 145		5 3/4 145	✳️ 45° ⊖ ◁ ◻ ◻ ◻	mirror polished	multi-component grips	15/32 12.0	1 3/8 35.0	19/64 7.5	3/32 2.5	3/64 1.0	0.23

- > precision pliers for ultra fine assembly work in electronics and fine mechanics
- > designed for gripping, holding and bending small components
- > electrically discharging handles – dissipative
- > precision box joint
- > smooth gripping surfaces and rounded edges prevent damage to components
- > low-friction double spring for gentle and even opening
- > the mirror polish, together with a fine film of oil, offer the best possible rust protection – no circuit faults caused by peeling chrome from plated tools
- > ball bearing chrome steel

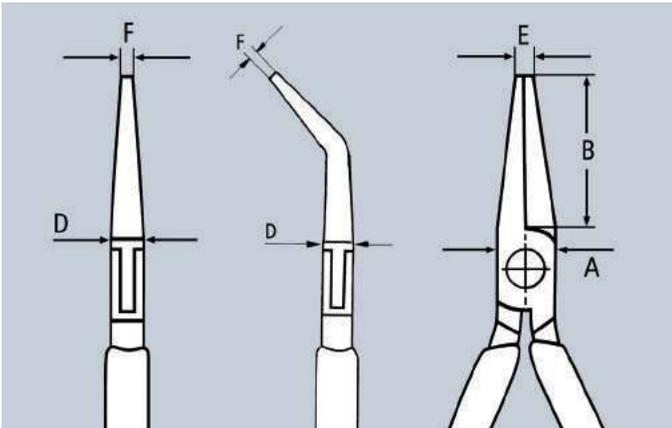

ESD pliers (electrostatic discharge)

Electrostatic energy is discharged through the handles in a gradual and controlled manner which protects components endangered by electrostatic discharge in accordance with applicable standards, e.g. IEC TR 61 340-5, DIN EN 61 340-5, SP Method 2472



35 12 115 ESD



35 22 115 ESD



35 32 115 ESD



35 42 115 ESD



Product Number	Packaging	↔ Inch mm	Icons	Head	Handles	Dimensions					⚖️ lbs
						A Inch mm	B Inch mm	D Inch mm	E Inch mm	F Inch mm	
35 12 115 ESD		4 1/2 115	ESD, Mirror, Box, Ball	mirror polished	ESD multi-component grips	3/8 9.5	57/64 22.5	17/64 6.7	5/64 2.0	5/32 4.0	0.16
35 22 115 ESD		4 1/2 115	ESD, Mirror, Box, Ball	mirror polished	ESD multi-component grips	3/8 9.5	57/64 22.5	17/64 6.7	5/64 2.0	1/16 1.5	0.16
35 32 115 ESD		4 1/2 115	ESD, Mirror, Box, Ball	mirror polished	ESD multi-component grips	3/8 9.5	57/64 22.5	17/64 6.7	5/64 2.0	3/64 1.0	0.15
35 42 115 ESD		4 1/2 115	ESD, Mirror, 45°, Box, Ball	mirror polished	ESD multi-component grips	3/8 9.5	57/64 22.5	17/64 6.7	5/64 2.0	1/16 1.5	0.16

- > precision pliers for very fine assembly and repair work in electronics
- > for bending and cutting off wire ends on components
- > precision box-joint for greater strength
- > smooth gripping surfaces
- > smooth edges
- > low-friction double spring for gentle and even opening
- > the mirror polish, together with a fine film of oil, offer the best possible rust protection - no circuit faults caused by peeling chrome from plated tools
- > special tool steel, forged, oil-hardened

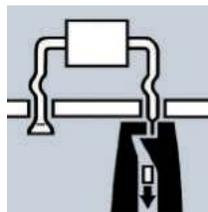
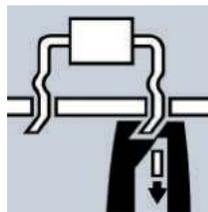
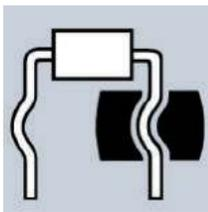
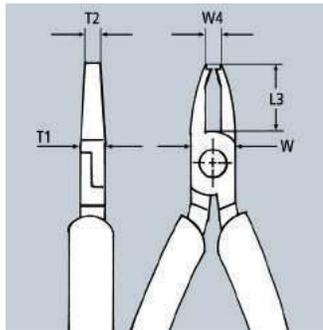
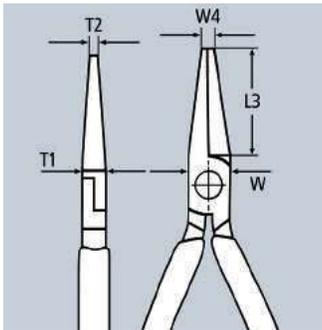
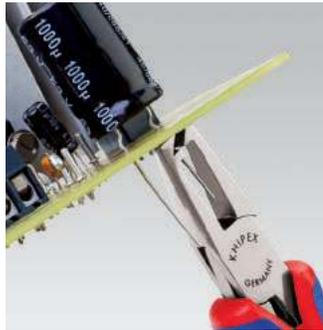

36 12 130
to bend wire in shape for the distance to the board

36 22 125
to bend and cut wire at 1/16" (1.6 mm) length below the board

36 32 125
to crunch and cut wire at 1/16" (1.6 mm) length below the board



36 12 130
✂️



36 22 125
✂️



36 32 125
✂️

Product Number	Packaging	↔ Inch mm		Head	Handles	Cutting capacities		Dimensions					 lbs
						∅ Inch ∅ mm	L3 Inch mm	W Inch mm	T1 Inch mm	W4 Inch mm	T2 Inch mm		
36 12 130		5 1/4 130		mirror polished	multi-component grips	-	29/32 23.0	15/32 12.0	3/8 9.5	7/32 5.5	15/64 6.0	0.21	
36 22 125		5 125		mirror polished	multi-component grips	3/64 1.2	23/32 18.25	29/64 11.5	19/64 7.5	19/64 7.5	7/64 2.6	0.21	
36 32 125		5 125		mirror polished	multi-component grips	3/64 1.2	23/32 18.25	29/64 11.5	19/64 7.5	19/64 7.5	5/32 4.0	0.21	

Gripping Pliers

for precision mechanics

DIN ISO 9655

37

- > precision pliers for ultra fine assembly work, e.g. in electronics and fine mechanics
- > for gripping, holding, bending and adjusting
- > smooth gripping surfaces and edges
- > lap joint
- > high-grade special tool steel; forged, oil-hardened

Style 1

Flat, wide jaws

Style 2

Flat, concave and pointed jaws

Style 3

Half-round jaws

Style 4

Round, pointed jaws to bend wire loops

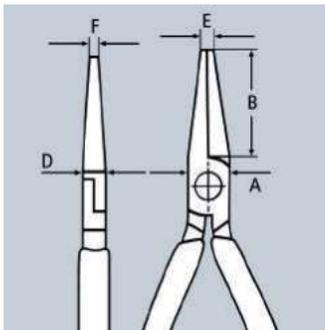

37 11 125



37 21 125



37 31 125



37 41 125



Product Number	Packaging	↔ Inch mm	Pliers	Head	Handles	Style	Dimensions					⚖ lbs	
							B Inch mm	A Inch mm	D Inch mm	E Inch mm	F Inch mm		
37 11 125		5 125		black atramentized	polished	plastic coated	1	1 1/16 27.0	31/64 12.5	9/32 7.0	5/64 2.0	7/32 5.5	0.17
37 21 125		5 125		black atramentized	polished	plastic coated	2	1 1/16 27.0	31/64 12.5	9/32 7.0	5/64 2.0	5/64 2.0	0.16
37 31 125		5 125		black atramentized	polished	plastic coated	3	1 1/16 27.0	31/64 12.5	9/32 7.0	5/64 2.0	1/16 1.6	0.16
37 41 125		5 125		black atramentized	polished	plastic coated	4	1 1/16 27.0	37/64 14.5	5/16 8.0	5/64 2.0	3/64 1.0	0.17

- > high-strength jaws and tips bend and snap back into place
- > cross-hatched gripping surfaces, knurled
- > vanadium electric steel; forged, oil-hardened

Style 1
Long, half-round jaws;
serrated gripping surfaces

Style 2
40° angled jaws

Style 3
Curved tips

Style 4
Long, trapezoidal jaws;
serrated gripping surfaces

Style 5
70° angled jaws; suitable for pulling
cotter pins and for hard to reach areas

Style 6
Double bent jaws

Style 7
45° angled, half-round jaws; suitable
for gripping spark plugs and round
components

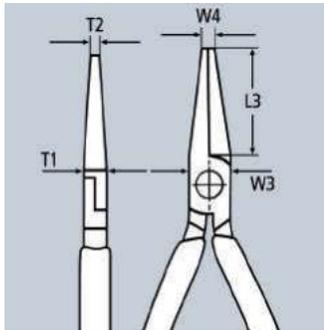

38 11 200
⊖ ⊗



38 21 200
∠40° ⊖ ⊗



38 31 200
⊖ ⊗



38 41 190
⊖ ⊗



38 71 200
∠70° ⊖ ⊗



38 81 200 A
⊖ ⊗



38 81 200 B
⊖ ⊗



38 91 200
∠45° ⊖ ⊗

Product Number	Packaging	↔ Inch mm	⊖ ⊗	Pliers	Head	Handles	Style	Dimensions					⚖ lbs
								L3 Inch mm	W3 Inch mm	T1 Inch mm	W4 Inch mm	T2 Inch mm	
38 11 200		8 200	⊖ ⊗	black atramentized	polished	plastic coated	1	2 7/8 73.0	11/16 17.5	3/8 9.5	1/8 3.0	3/32 2.5	0.40
38 21 200		8 200	∠40° ⊖ ⊗	black atramentized	polished	plastic coated	2	2 7/8 73.0	11/16 17.5	3/8 9.5	1/8 3.0	3/32 2.5	0.39
38 31 200		8 200	⊖ ⊗	black atramentized	polished	plastic coated	3	2 7/8 73.0	11/16 17.5	3/8 9.5	1/8 3.0	3/32 2.5	0.39
38 41 190		7 1/2 190	⊖ ⊗	black atramentized	polished	plastic coated	4	1 31/32 50.0	45/64 18.0	5/16 8.0	5/32 4.0	5/16 8.0	0.33
38 71 200		8 200	∠70° ⊖ ⊗	black atramentized	polished	plastic coated	5	2 7/8 73.0	11/16 17.5	3/8 9.5	1/8 3.0	5/64 2.0	0.40
38 81 200 A		8 200	⊖ ⊗	black atramentized	polished	plastic coated	6	2 3/4 69.0	45/64 18.0	3/8 9.5	1/8 3.0	3/32 2.5	0.39
38 81 200 B		8 200					6	2 3/64 62.0	45/64 18.0	3/8 9.5	1/8 3.0	3/32 2.5	0.39
38 91 200		8 200	∠45° ⊖ ⊗	black atramentized	polished	plastic coated	7	2 7/8 73.0	11/16 17.5	3/8 9.5	-	3/32 2.5	0.39

- > tightly holds round or flat material
- > heavy-duty
- > adjustment screw and release lever for easy use
- > one-handed operation
- > high clamping pressure due to toggle lever action
- > pliers body: rolled steel, high-strength
- > gripping jaws: chrome vanadium electric steel; forged

40 14 250

With pivoting bottom jaw that automatically adjusts to the workpiece no matter the shape



40 04 250



40 14 250



WARNING: This product can expose you to chemicals including Diisononyl Phthalate, which is known to the State of California to cause cancer. For more information go to www.P65Warnings.ca.gov

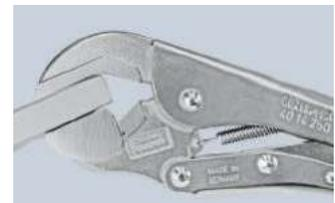

Product Number	Packaging	↔ Inch mm		○ Inch mm	⬡ Inch mm	⚖ lbs
40 04 180		7 1/4 180		1 3/8 35	1 1/4 32	0.82
40 04 250		10 250	▨	1 3/8 35	1 1/4 32	1.22
40 14 250		10 250	▨	1 11/16 43	1 25/32 45	1.35



- > tightly holds round or flat material
- > heavy-duty
- > adjustment screw and release lever for easy use
- > one-handed operation
- > high clamping pressure due to toggle lever action
- > pliers body: rolled steel, high-strength
- > gripping jaws: chrome vanadium electric steel; forged

Style 0

Jaws for round workpieces, with wire cutter

Style 1

Jaws with double prism for round, section and flat material

Style 2

Straight jaws for flat material

Style 3

Long Nose Grip Pliers, narrow, long jaws

Style 4

Long Nose Grip Pliers, narrow long jaws very suitable for areas that are difficult to reach. Non-serrated gripping area for pinching off hoses

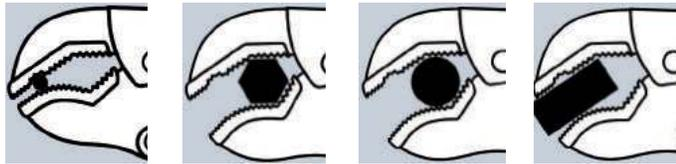

41 04 250



41 14 250



41 24 225



41 34 165



41 44 200



WARNING: This product can expose you to chemicals including Diisononyl Phthalate, which is known to the State of California to cause cancer. For more information go to www.P65Warnings.ca.gov

Product Number	Packaging	↔ Inch mm		Pliers	Style	○ Inch mm	⬡ Inch mm	⚖ lbs
41 04 180		7 1/4 180			0	1 3/16 30	1 3/16 30	0.82
41 04 250		10 250		bright zinc plated	0	1 37/64 40	1 3/16 30	1.23
41 04 300		12 300			0	2 9/16 65	1 11/32 34	2.08
41 14 250		10 250		bright zinc plated	1	1 27/64 36	1 27/64 36	1.29
41 24 225		9 225		bright zinc plated	2	1 25	1 3/16 30	1.16
41 34 165		6 1/2 165		bright zinc plated	3	13/16 20	15/16 24	0.42
41 44 200		8 200		bright zinc plated	4	13/16 20	1 3/16 30	0.88

- > for gripping, clamping and holding of diverse profiles
- > heavy-duty
- > with adjustment screw and release lever
- > one-handed operation
- > high clamping pressure due to toggle lever action
- > pliers body: rolled steel, high-strength

42 14 280

Heat resistant malleable cast iron jaws; section or flat material items lying side by side are held securely during welding; also for section material with vertical webs up to 1" (25 mm) height

42 24 280

Heat resistant malleable cast iron jaws; round or tubular material items lying centrally side by side are held securely during welding

42 34 280

Gripping jaws made of chrome vanadium steel, drop forged; clamp cumbersome workpieces and sections with high webs up to 1 37/64" (40 mm)

42 44 280

Pivoting jaws; gripping jaws made of chrome vanadium steel, drop forged; clamp and balance bulky work components and profiles with high ridges up to 1 37/64" (40 mm)



42 14 280



42 24 280



42 34 280



42 44 280

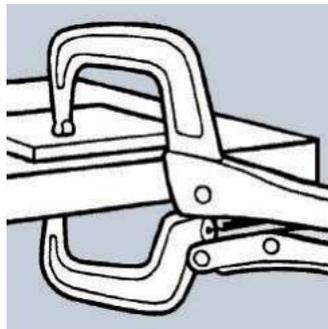
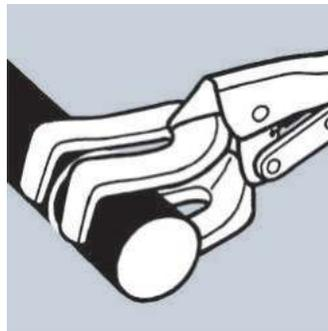

⚠ WARNING: This product can expose you to chemicals including Diisononyl Phthalate, which is known to the State of California to cause cancer. For more information go to www.P65Warnings.ca.gov

Product Number	Packaging	↔ Inch mm	Pliers	○ Inch mm	□ Inch mm	⚖ lbs
42 14 280		11 280	bright zinc plated	1 3/16 - 2 9/16 30-65	-	2.04
42 24 280		11 280	bright zinc plated	25/64 - 2 3/4 10-70	-	2.02
42 34 280		11 280	bright zinc plated	-	3 1/2 90	1.53
42 44 280		11 280	bright zinc plated	-	3 1/2 90	1.65

Circlip Pliers

for large internal circlips

44

- > for assembling snap rings into bores within the range of 4 51/64" – 16" (122-400 mm) dia.
- > with locking device, can be released without completing cycle
- > with replaceable tips made of tempered steel
- > pliers body: rolled steel, high-strength
- > tips: special tool steel; oil-hardened

Style 1
Straight tips

Style 2
90° angled tips



44 10 J6





44 20 J61



Product Number	Packaging	↔ Inch mm		Pliers	Style	Size of bore Ø Inch Ø mm	Tips Ø Inch Ø mm	⚖ lbs
44 10 J5		22 29/64 570	 	black powder-coated	1	4 51/64 - 12 122 - 300	9/64 3.5	3.88
44 10 J6		22 3/4 580			1	9 59/64 - 16 252 - 400	11/64 4.5	3.88
44 20 J51		23 1/4 590	  	black powder-coated	2	4 51/64 - 12 122 - 300	9/64 3.5	4.00
44 20 J61		23 1/2 600			2	9 59/64 - 16 252 - 400	11/64 4.5	4.02
44 19 J5	1 pair of spare tips for 44 10 J5							
44 19 J6	1 pair of spare tips for 44 10 J6							
44 29 J51	1 pair of spare tips for 44 20 J51							
44 29 J61	1 pair of spare tips for 44 20 J61							

Circlip Pliers

for large external circlips

46

- > for assembling snap rings on shafts, ranging from 4 51/64" – 16" (122–400 mm) dia.
- > with locking device, can be released without completing cycle
- > with replaceable tips made of tempered steel
- > pliers body: rolled steel; high-strength
- > tips: special tool steel; oil-hardened

Style 1
Straight tips

Style 2
90° angled tips



46 10 A5





46 20 A61



Product Number	Packaging	↔ Inch mm		Pliers	Style	Size of shaft Ø Inch Ø mm	Tips Ø Inch Ø mm	⚖ lbs
46 10 A5		22 560	 	black powder-coated	1	4 51/64 - 12 122 - 300	9/64 3.5	3.91
46 10 A6		22 29/64 570			1	9 59/64 - 16 252 - 400	11/64 4.5	3.96
46 20 A51		22 29/64 570	  	black powder-coated	2	4 51/64 - 12 122 - 300	9/64 3.5	4.06
46 20 A61		22 3/4 580			2	9 59/64 - 16 252 - 400	11/64 4.5	4.11
46 19 A5	1 pair of spare tips for 46 10 A5							
46 19 A6	1 pair of spare tips for 46 10 A6							
46 29 A51	1 pair of spare tips for 46 20 A51							
46 29 A61	1 pair of spare tips for 46 20 A61							

Circlip Pliers

for internal circlips in bore holes

44

> for fitting snap rings into bores, ranging from 5/16" to 5 1/2" (8–140 mm) dia.

> solid style, forged
> non-slip, solid tips

> pliers body and tips: chrome vanadium steel; forged, oil-hardened

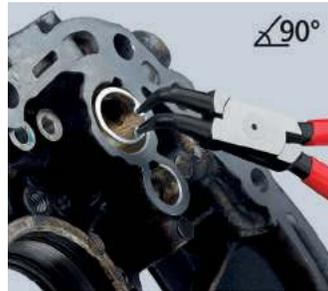

44 11 J2
○



44 21 J21
○ ∠90°



44 31 J22
○ ∠45°

Style 1
Straight tips

Style 2
90° angled tips

Style 3
45° angled tips

Product Number	Packaging	↔ Inch mm		Pliers	Head	Handles	Style	Size of bore Ø Inch Ø mm	Tips Ø Inch Ø mm	⚖ lbs
44 11 J0	X	5 1/2 140	○	black atramentized	polished	plastic coated	1	5/16 - 1/2 8 - 13	1/32 0.9	0.20
44 11 J1	X	5 1/2 140					1	15/32 - 1 12 - 25	3/64 1.3	0.20
44 11 J2	X	7 1/4 180					1	3/4 - 3/64 19 - 60	5/64 1.8	0.30
44 11 J3	X	9 225					1	1 37/64 - 3 15/16 40 - 100	3/32 2.3	0.43
44 11 J4	X	12 1/2 320					1	3 11/32 - 5 1/2 85 - 140	1/8 3.2	1.03
44 21 J01	X	5 1/8 130	○ ∠90°	black atramentized	polished	plastic coated	2	5/16 - 1/2 8 - 13	1/32 0.9	0.19
44 21 J11	X	5 1/8 130					2	15/32 - 1 12 - 25	3/64 1.3	0.19
44 21 J21	X	6 3/4 170					2	3/4 - 2 3/64 19 - 60	5/64 1.8	0.31
44 21 J31	X	8 1/2 215					2	1 37/64 - 3 15/16 40 - 100	3/32 2.3	0.43
44 21 J41	X	12 300					2	3 11/32 - 5 1/2 85 - 140	1/8 3.2	1.02
44 31 J02	X	5 1/2 140	○ ∠45°	black atramentized	polished	plastic coated	3	5/16 - 1/2 8 - 13	1/32 0.9	0.20
44 31 J12	X	5 1/2 140					3	15/32 - 1 12 - 25	3/64 1.3	0.20
44 31 J22	X	7 180					3	3/4 - 2 3/64 19 - 60	5/64 1.8	0.31
44 31 J32	X	9 225					3	1 37/64 - 3 15/16 40 - 100	3/32 2.3	0.43
44 31 J42	X	12 11/32 310					3	3 11/32 - 5 1/2 85 - 140	1/8 3.2	1.03

Circlip Pliers

for external circlips on shafts

46

- > for fitting snap rings on shafts, ranging from 1/8" – 5 1/2" (3 – 140 mm) dia.
- > solid style, forged
- > non-slip, solid tips
- > pliers body and tips: chrome vanadium steel; forged, oil-hardened



46 11 A2
 MM



46 21 A21
 MM



46 31 A22
 MM

Style 1
 Straight tips

Style 2
 90° angled tips

Style 3
 45° angled tips

Product Number	Packaging	↔ Inch mm	⊙ MM	Pliers	Head	Handles	Style	Size of shaft ∅ Inch ∅ mm	Tips ∅ Inch ∅ mm	⚖ lbs
46 11 A0	X	5 1/2 140	⊙ MM	black atramentized	polished	plastic coated	1	1/8 - 25/64 3 - 10	1/32 0.9	0.19
46 11 A1	X	5 1/2 140					1	25/64 - 1 10 - 25	3/64 1.3	0.19
46 11 A2	X	7 1/4 180					1	3/4 - 2 3/64 19 - 60	5/64 1.8	0.30
46 11 A3	X	8 1/4 210					1	1 37/64 - 3 15/16 40 - 100	3/32 2.3	0.49
46 11 A4	X	12 1/2 320					1	3 11/32 - 5 1/2 85 - 140	1/8 3.2	1.11
46 21 A01	X	5 125	⊙ 90° MM	black atramentized	polished	plastic coated	2	1/8 - 25/64 3 - 10	1/32 0.9	0.19
46 21 A11	X	5 125					2	25/64 - 1 10 - 25	3/64 1.3	0.19
46 21 A21	X	6 3/4 170					2	3/4 - 2 3/64 19 - 60	5/64 1.8	0.29
46 21 A31	X	8 200					2	1 37/64 - 3 15/16 40 - 100	3/32 2.3	0.48
46 21 A41	X	12 300					2	3 11/32 - 5 1/2 85 - 140	1/8 3.2	1.12
46 31 A02	X	5 1/2 140	⊙ 45° MM	black atramentized	polished	plastic coated	3	1/8 - 25/64 3 - 10	1/32 0.9	0.19
46 31 A12	X	5 1/2 140					3	25/64 - 1 10 - 25	3/64 1.3	0.19
46 31 A22	X	7 1/4 180					3	3/4 - 2 3/64 19 - 60	5/64 1.8	0.30
46 31 A32	X	8 1/4 210					3	1 37/64 - 3 15/16 40 - 100	3/32 2.3	0.47
46 31 A42	X	12 11/32 310					3	3 11/32 - 5 1/2 85 - 140	1/8 3.2	1.13

Precision Circlip Pliers

for internal circlips in bore holes

48

With inserted tips for reliable work
 Heavy-duty in continuous operation:
 up to 10 times longer service life than
 turned tips



- > for fitting snap rings into bores, ranging from 5/16" to 5 1/2" (8 – 140 mm) dia.
- > bolted joint: precise, zero-backlash operation of pliers
- > pliers body: chrome vanadium electric steel; forged, oil-hardened
- > inserted tips: spring steel wire, drawn

Style 1

Straight tips

Style 2

90° angled tips



48 11 J2



48 21 J21



High Precision Quality

Easy and reliable assembly: form-fitting inserted and pressed-in tips made of high-density spring steel offer a high level of protection against excessive stress and strain, e.g. when removing stuck rings. The large supporting surfaces and the position of the tips make it more difficult for the rings to fly off.

Precision and durability

High-density spring steel with a score-free surface is used for the tips. This increases the tips' resistance to dynamic and static strain. The tips are 30% more stable than conventional pliers when subjected to one-off overloading while still allowing good accessibility during assembly. Subjected to dynamic strain, the tips' resistance capacity is up to 10 times greater! The tips on the precision circlip pliers are non-detachable!



Sturdy, inserted tips: made from high-density spring steel

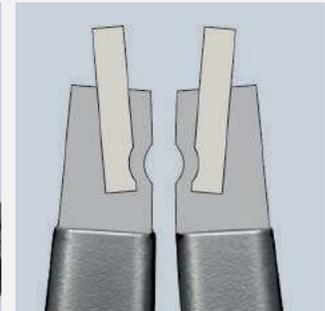

Tight fit through compression

Product Number	Packaging	↔ Inch mm		Pliers	Handles	Style	Size of bore Ø Inch Ø mm	Tips Ø Inch Ø mm	⚖ lbs
48 11 J0	X	5 1/2 140		grey atramentized	non-slip plastic coated	1	5/16 - 1/2 8 - 13	1/32 0.9	0.23
48 11 J1	X	5 1/2 140				1	15/32 - 1 12 - 25	3/64 1.3	0.23
48 11 J2	X	7 1/4 180				1	3/4 - 2 3/64 19 - 60	5/64 1.8	0.39
48 11 J3	X	9 225				1	1 37/64 - 3 15/16 40 - 100	3/32 2.3	0.59
48 11 J4	X	12 1/2 320				1	3 11/32 - 5 1/2 85 - 140	1/8 3.2	1.24
48 21 J01	X	5 1/8 130		grey atramentized	non-slip plastic coated	2	5/16 - 1/2 8 - 13	1/32 0.9	0.23
48 21 J11	X	5 1/8 130				2	15/32 - 1 12 - 25	3/64 1.3	0.23
48 21 J21	X	6 1/2 165				2	3/4 - 2 3/64 19 - 60	5/64 1.8	0.39
48 21 J31	X	8 1/4 210				2	1 37/64 - 3 15/16 40 - 100	3/32 2.3	0.59
48 21 J41	X	12 305				2	3 11/32 - 5 1/2 85 - 140	1/8 3.2	1.24

NEW

NOW with overstretching limiter
For all circlips with a diameter of 5/16" – 3 15/16"

- > overexpansion limiter with screw stop prevents overexpansion of circlips
- > adjustment using Allen Wrench

Style 3
 Straight tips with overstretching limiter
 (adjustable using end stop)

Style 4
 90° angled tips with overstretching limiter
 (adjustable using end stop)



48 31 J2



48 41 J21

KNIPEX Precision Circlip Pliers with overexpansion guard

For the standardized fitting of circlips in the industrial serial production. Particularly manufacturers of sensitive, safety-relevant components (e.g. brakes or gears) highly appreciate the compliance of DIN 471 and 472. The mounting of circlip rings in this case requires pliers with an overexpansion guard or a cone. KNIPEX Circlip Pliers with overexpansion guard meet the requirements and offer a superior durability.



Product Number	Packaging	↔ Inch mm		Pliers	Handles	Style	Size of bore Ø Inch Ø mm	Tips Ø Inch Ø mm	⚖ lbs
48 31 J0		5 1/2 140		grey atramentized	non-slip plastic coated	3	5/16 - 1/2 8 - 13	1/32 0.9	0.23
48 31 J1		5 1/2 140				3	15/32 - 1 12 - 25	3/64 1.3	0.23
48 31 J2		7 1/4 180				3	3/4 - 2 3/64 19 - 60	5/64 1.8	0.39
48 31 J3		9 225				3	1 37/64 - 3 15/16 40 - 100	3/32 2.3	0.59
48 41 J01		5 1/8 130		grey atramentized	non-slip plastic coated	4	5/16 - 1/2 8 - 13	1/32 0.9	0.23
48 41 J11		5 1/8 130				4	15/32 - 1 12 - 25	3/64 1.3	0.23
48 41 J21		6 1/2 165				4	3/4 - 2 3/64 19 - 60	5/64 1.8	0.39
48 41 J31		8 1/4 210				4	1 37/64 - 3 15/16 40 - 100	3/32 2.3	0.59

Precision Circlip Pliers

to assemble external circlips on shafts

49

With inserted tips for reliable work

Heavy-duty in continuous operation: up to 10 times longer service life compared to turned tips



- > for fitting snap rings on shafts, ranging from 1/8" – 5 1/2" (3 – 140 mm) dia.
- > large contact faces on the tips: no distortion of circlips, easy fitting
- > bolted joint: precise, zero-backlash operation of pliers
- > internal opening spring, protected and captive
- > pliers body: chrome vanadium electric steel; forged, oil-hardened
- > inserted tips: spring steel wire, drawn

Style 1

Straight tips

Style 2

90° angled tips

49 11 A2



49 21 A21



High Precision Quality

Easy and reliable assembly: form-fitting inserted and pressed-in tips made of high-density spring steel offer a high level of protection against excessive stress and strain, e.g. when removing stuck rings. The large supporting surfaces and the position of the tips make it more difficult for the rings to fly off.



Spring inside the joint: the spring is protected inside the precision bolted joint. It does not hinder work and cannot get dirty or lost



Circlips are held securely: large contact faces and the position of the tips make it difficult for the circlip to fly off

Precision and durability

High-density spring steel with a score-free surface is used for the tips. This increases the tips' resistance to dynamic and static strain. The tips are 30% more stable than conventional pliers when subjected to one-off overloading while still allowing good accessibility during assembly. Subjected to dynamic strain, the tips' resistance capacity is up to 10 times greater! The tips on the precision circlip pliers are non-detachable!



Sturdy, inserted tips: made from high-density spring steel

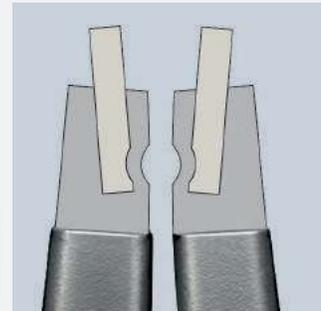

Tight fit through compression

Product Number	Packaging	↔ Inch mm		Pliers	Handles	Style	Size of shaft Ø Inch Ø mm	Tips Ø Inch Ø mm	⚖ lbs
49 11 A0	X	5 1/2 140	○ MM	grey atramentized	non-slip plastic coated	1	1/8 - 25/64 3 - 10	1/32 0.9	0.22
49 11 A1	X	5 1/2 140				1	25/64 - 1 10 - 25	3/64 1.3	0.22
49 11 A2	X	7 1/4 180				1	3/4 - 2 3/64 19 - 60	5/64 1.8	0.38
49 11 A3	X	9 225				1	1 37/64 - 3 15/16 40 - 100	3/32 2.3	0.60
49 11 A4	X	12 5/8 320				1	3 11/32 - 5 1/2 85 - 140	1/8 3.2	1.32
49 21 A01	X	5 1/8 130	○ $\angle 90^\circ$ MM	grey atramentized	non-slip plastic coated	2	1/8 - 25/64 3 - 10	1/32 0.9	0.22
49 21 A11	X	5 1/8 130				2	25/64 - 1 10 - 25	3/64 1.3	0.22
49 21 A21	X	6 1/2 165				2	3/4 - 2 3/64 19 - 60	5/64 1.8	0.38
49 21 A31	X	8 1/4 210				2	1 37/64 - 3 15/16 40 - 100	3/32 2.3	0.60
49 21 A41	X	12 305				2	3 11/32 - 5 1/2 85 - 140	1/8 3.2	1.32

NEW

NOW with overstretching limiter
For all circlips with a diameter of 5/16" – 3 15/16"

- > overexpansion limiter with screw stop prevents overexpansion of circlips
- > adjustment using Allen Wrench

Style 3

Straight tips with overexpansion limiter (adjustable using end stop)

Style 4

90° angled tips with overexpansion limiter (adjustable using end stop)



Style 3 / style 4: with adjustable restricted opening



49 31 A0
 MM



49 31 A2
 MM

KNIPEX Precision Circlip Pliers with overexpansion guard

For the standardized fitting of circlips in the industrial serial production. Particularly manufacturers of sensitive, safety-relevant components (e.g. brakes or gears) highly appreciate the compliance of DIN 471 and 472. The mounting of circlip rings in this case requires pliers with an overexpansion guard or a cone. KNIPEX Circlip Pliers with overexpansion guard meet the requirements and offer a superior durability.



49 41 A11
 MM



Product Number	Packaging	↔ Inch mm		Pliers	Handles	Style	Size of shaft Ø Inch Ø mm	Tips Ø Inch Ø mm	⚖ lbs
49 31 A0		5 1/2 140	MM	grey atramentized	non-slip plastic coated	3	1/8 - 25/64 3 - 10	1/32 0.9	0.23
49 31 A1		5 1/2 140				3	25/64 - 1 10 - 25	3/64 1.3	0.22
49 31 A2		7 1/4 180				3	3/4 - 2 3/64 19 - 60	5/64 1.8	0.38
49 31 A3		9 225				3	1 37/64 - 3 15/16 40 - 100	3/32 2.3	0.60
49 41 A01		5 1/8 130	MM	grey atramentized	non-slip plastic coated	4	1/8 - 25/64 3 - 10	1/32 0.9	0.23
49 41 A11		5 1/8 130				4	25/64 - 1 10 - 25	3/64 1.3	0.22
49 41 A21		6 1/2 165				4	3/4 - 2 3/64 19 - 60	5/64 1.8	0.38
49 41 A31		8 1/4 210				4	1 37/64 - 3 15/16 40 - 100	3/32 2.3	0.60

Special Retaining Ring Pliers

for retaining rings on shafts

DIN ISO 5743

45

- > for fitting horseshoe-shaped spring retaining rings and circlips without grip holes
- > for shaft retaining devices
- > with opening spring
- > chrome vanadium electric steel; forged, oil-hardened



45 10 170
  



45 21 200
 $\angle 30^\circ$ 

45 10 170

For retaining rings with a minimum ring split gap of 9/64" (3.6 mm)

45 21 200

Angled jaws with centering hole; for snap rings larger than 15/32" (12.0 mm) dia., e. g. for securing drive shaft in the gearbox of a motor vehicle; minimum ring split gap of the rings 3/32" (2.2 mm)



45 10 170



45 21 200



45 21 200

Product Number	Packaging	↔ Inch mm		Pliers	Handles	 lbs
45 10 170		6 3/4 170		burnished	burnished	0.34
45 21 200		8 200		burnished	plastic coated	0.41

Circlip Pliers

for grip rings on shafts

DIN ISO 5743

46

- > for fitting grip rings on shafts ranging from 1/16" – 1 3/16" (1.5–30 mm) dia.
- > includes opening spring for easy repetitive work
- > solid style, forged
- > non-slip, solid tips
- > pliers body and tips: chrome vanadium steel; forged, oil-hardened



46 11 G0
 

46 11 G0

Adjustable stop screw to prevent overstretching, for rings from 1/16" - 1 5/32" (1.5 - 4.0 mm) dia.

Product Number	Packaging	↔ Inch mm		Pliers	Head	Handles	Size of shaft Ø Inch Ø mm	Tips Ø Inch Ø mm	 lbs
46 11 G0		5 1/2 140		black atramentized	polished	non-slip plastic coated	1/16 - 5/32 1.5 - 4.0	1/32 0.9	0.19
46 11 G1		5 1/2 140		black atramentized	polished	non-slip plastic coated	5/32 - 9/32 4.0 - 7.0	3/64 1.3	0.19
46 11 G2		5 1/2 140					13/64 - 1/2 5.0 - 13.0	5/64 1.8	0.19
46 11 G3		5 1/2 140					35/64 - 45/64 14.0 - 18.0	3/32 2.3	0.19
46 11 G4		7 1/4 180					25/32 - 1 3/16 20.0 - 30.0	1/8 3.2	0.30

Circlip Tool

for internal and external circlips

46

- > universal usage for large circlips with nominal diameters of 16" – 39 3/8" (400–1000 mm)
- > reliable opening and closing of the circlips and holding by self-locking precision spindle drive
- > for fitting and removing circlips in one operation
- > circlips are securely held due to short, direct attachment
- > replaceable tips with 15/64" (6 mm) and 23/64" (9 mm) diameters, for perfect adaption to the actuation bores in the circlips
- > optional operation with hexagonal key, ratchet wrench or cordless screwdriver
- > areas of application e.g. wind turbines, tidal power stations, generator construction, hydropower stations, large machine construction (rolling mills, presses), shipbuilding, aerospace – wherever very high forces and torques are transmitted with large shafts and bearings
- > tip material: chrome vanadium electric steel



46 10 100



Manually operable



Machine operable



Replaceable inserts for internal and external circlips



Product Number	Packaging		Size of bore Ø Inch Ø mm	Size of shaft Ø Inch Ø mm	⚖ lbs
46 10 100	Plastic case with foam insert	⊙ ⊙	16 - 39 3/8 400 - 1000	16 - 39 3/8 400 - 1000	4.75

- > heavy-duty
- > preferred by tradespeople
- > wear-resistant
- > cutting edge hardness (approx. 60 HRC)
- > special tool steel; forged, oil-hardened

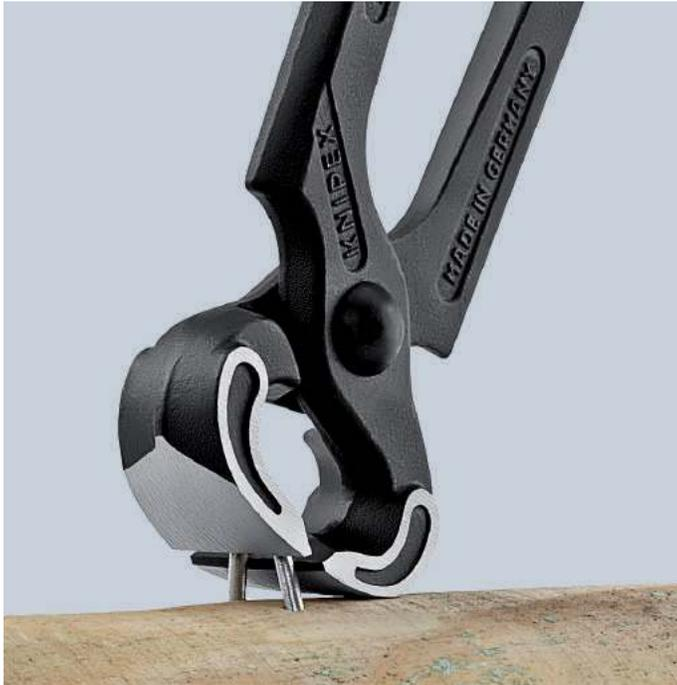

50 00 210



50 01 225



Product Number	Packaging	↔ Inch mm	Pliers	Head	Handles	Cutting capacities	
						● Ø Inch Ø mm	⚖ lbs
50 00 160		6 1/4 160	✔ black atramentized	polished	black atramentized	5/64 1.8	0.49
50 00 180		7 180				5/64 2.0	0.70
50 00 210		8 1/4 210				3/32 2.2	0.94
50 00 250		10 250				3/32 2.2	1.27
50 00 300		12 300				3/32 2.4	1.87
50 01 160		6 1/4 160	✔ black atramentized	polished	plastic coated	5/64 1.8	0.53
50 01 180		7 1/4 180				5/64 2.0	0.73
50 01 210		8 1/4 210				3/32 2.2	0.98
50 01 225		9 225				3/32 2.2	1.34
50 01 250		10 250				3/32 2.2	1.29
50 01 300		12 300				3/32 2.4	1.99

Carpenters' Pincers

DIN ISO 9243

51

- > with striking face for driving in nails
- > cutting edge hardness (approx. 60 HRC)
- > special tool steel; forged, multi stage oil-hardened



51 01 210



Product Number	Packaging	↔ Inch mm		Pliers	Head	Handles	⚖ lbs
51 01 210		8 1/4 210		black atramentized	polished	plastic coated	1.00

Farriers' Pincers

Break-off Pliers for vehicle bodywork
DIN ISO 5743

55

- > the ideal pliers for the farrier
- > with small head and reversing groove
- > suitable for dismantling work in vehicle body workshops
- > cutting edge hardness (approx. 59 HRC)
- > special tool steel; forged, multi stage oil-hardened



55 00 300



Product Number	Packaging	↔ Inch mm		Pliers	Head	Head width Inch mm	⚖ lbs
55 00 300		12 300		black atramentized	polished	25/32 20.0	1.73

Concreters' Nippers

(tower pincers, steel fixers' nippers)

DIN ISO 9242

99
0

- > to twist and cut wire in one operation: fast, reliable and economical
- > precision and long service life make these the most widely purchased concreters' nippers in the world
- > induction hardened cutting edges, cutting edge hardness (approx. 61 HRC)
- > high-grade special tool steel; forged, multi stage oil-hardened

99 00 220 K12

With 15/32" (12 mm) head, particularly suitable for tile paving work



99 00 200



99 00 280



99 00 300



99 00 220 K12



99 01 220



Product Number	Packaging	↔ Inch mm	Pliers	Head	Handles	Cutting capacities		⚖️ lbs	
						● Ø Inch Ø mm	● Ø Inch Ø mm		
99 00 200		8 200	✔️ black atramentized	polished		5/64 1.8	1/16 1.4	0.51	
99 00 220		8 3/4 220				3/32 2.4	1/16 1.6		0.69
99 00 220 K12		8 3/4 220	✔️ black atramentized	polished		3/32 2.4	1/16 1.6	0.69	
99 00 250	X	10 250	✔️ black atramentized	polished		3/32 2.4	1/16 1.6	0.88	
99 00 280		11 280				7/64 2.8	5/64 1.8		1.00
99 00 300		12 300				1/8 3.1	5/64 1.8		
99 01 200	X	8 200	✔️ black atramentized	polished	plastic coated	5/64 1.8	1/16 1.4	0.55	
99 01 220	X	8 3/4 220				3/32 2.4	1/16 1.6		0.74
99 01 250	X	10 250				3/32 2.4	1/16 1.6	0.95	
99 01 280		11 280				7/64 2.8	5/64 1.8		1.10
99 01 300		12 300				1/8 3.1	5/64 1.8	1.21	

High Leverage Concreters' Nippers

with high lever transmission
DIN ISO 9242

99
1

25% less effort required compared to conventional concreters' nippers of the same size

Extra-slim form for tying deep mounted steel rods

- > for use when working with concrete steel and binding wire
- > twists and cuts wire in one operation
- > high leverage joint minimizes strain when working with thick binding wires
- > high leverage design reduces strain on tendons and muscles
- > cutting edge hardness (approx. 61 HRC)
- > high-grade special tool steel; forged, multi stage oil-hardened



99 10 250



99 10 300



99 11 300



99 14 250



99 14 300



Product Number	Packaging	↔ Inch mm	Pliers	Head	Handles	Cutting capacities		Head width Inch mm	⚖ lbs
						● Ø Inch Ø mm	● Ø Inch Ø mm		
99 10 250		10 250	✔ black atramentized	polished	-	1/8 3.3	5/64 1.8	1 25.0	0.77
99 10 300	X	12 300				5/32 3.8	5/64 2.0	1 25.0	1.11
99 11 250		10 250	✔ black atramentized	polished	plastic coated	1/8 3.3	5/64 1.8	1 25.0	0.77
99 11 300		12 300				5/32 3.8	5/64 2.0	1 25.0	1.18
99 14 250		10 250	✔ bright zinc plated	-	-	1/8 3.3	5/64 1.8	1 25.0	0.77
99 14 300		12 300				5/32 3.8	5/64 2.0	1 25.0	1.10

Bolt End Cutting Nippers

high lever transmission

DIN ISO 5743

61

Powerful, compact, comfortable

- > features a greater cutting capacity and requires less effort than conventional end cutting nippers
- > cuts nails, small bolts and all wires including piano wire
- > exceptional cutting capacity due to high leverage joint
- > cutting edge hardness (approx. 64 HRC)
- > vanadium steel; forged, multi stage oil-hardened

61 02 200

Slim two-color multi-component sleeves for better handling and easier transport; large contact surface on the handles for better allotment of pressure and more comfort at work



61 01 200



61 02 200



High cutting performance: also for piano wire



Perfect for working with fencing



Almost flush cutting of bolts, nails, etc.

Product Number	Packaging	↔ Inch mm	Pliers	Head	Handles	Cutting capacities				⚖️ lbs	
						⊘ Inch ⊘ mm	⊘ Inch ⊘ mm	⊘ Inch ⊘ mm	⊘ Inch ⊘ mm		
61 01 200	X	8 200	∠5°	black atramentized	polished	plastic coated	3/64 - 15/64 1.0 - 6.0	5/32 4.0	9/64 3.5	1/8 3.0	0.96
61 02 200		8 200	∠5°	black atramentized	polished	slim multi-component grips	3/64 - 15/64 1.0 - 6.0	5/32 4.0	9/64 3.5	1/8 3.0	1.03

High Leverage End Cutting Nippers

DIN ISO 5748

67

- > cutting edges for soft, hard and piano wire
- > high cutting capacity with minimal effort due to optimum coordination of cutting edge angle and transmission ratio
- > cutting edge hardness (approx. 64 HRC)
- > chrome vanadium heavy-duty steel; forged, multi stage oil-hardened



67 01 200



Product Number	Packaging	↔ Inch mm	Pliers	Head	Handles	Cutting capacities				⚖️ lbs
						⊘ Inch ⊘ mm	⊘ Inch ⊘ mm	⊘ Inch ⊘ mm	⊘ Inch ⊘ mm	
67 01 140		5 1/2 140				5/32 4.0	1/8 3.1	5/64 2.0	1/16 1.5	0.34
67 01 160		6 1/4 160		polished	plastic coated	11/64 4.5	9/16 3.4	3/32 2.5	5/64 2.0	0.52
67 01 200	X	8 200				13/64 5.0	5/32 3.8	1/8 3.0	3/32 2.5	0.70

End Cutting Nippers

68

Head shape provides optimized movement when tightening steel mesh knots during reinforced concrete work

- > cutting edges for soft and hard wire
- > also suitable for twisting and cutting binding wire
- > cutting edges are induction hardened; cutting edge hardness (approx. 61 HRC)
- > high-grade special tool steel; forged, multi stage oil-hardened



68 01 180



68 01 280



Product Number	Packaging	↔ Inch mm	Pliers	Head	Handles	Cutting capacities			⚖ lbs
						⊘ Inch ⊘ mm	⊘ Inch ⊘ mm	⊘ Inch ⊘ mm	
68 01 160		6 1/4 160	✔ black atramentized	polished	plastic coated	5/32 4.0	7/64 2.8	3/32 2.3	0.45
68 01 180		7 1/4 180				5/32 4.0	1/8 3.2	3/32 2.5	0.66
68 01 200	X	8 200				5/32 4.0	9/64 3.5	7/64 2.8	0.74
68 01 280	X	11 280				11/64 4.5	5/32 4.0	1/8 3.2	1.03

End Cutting Nippers

for mechanics
DIN ISO 5748

69

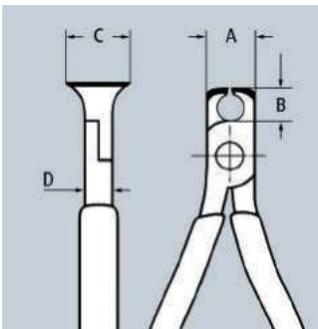

- > cutting edges for soft, hard and piano wire; also suitable for thin copper wires
- > lap joint
- > cutting edge hardness (approx. 64 HRC)
- > chrome vanadium heavy-duty steel; forged, multi stage oil-hardened



69 01 130



Product Number	Packaging	↔ Inch mm	Pliers	Head	Handles	Cutting capacities				Dimensions				⚖ lbs
						⊘ Inch ⊘ mm	⊘ Inch ⊘ mm	⊘ Inch ⊘ mm	⊘ Inch ⊘ mm	A Inch mm	B Inch mm	D Inch mm	C Inch mm	
69 01 130		5 1/8 130	✔ black atramentized	polished	plastic coated	1/64 - 5/64 0.4 - 2.0	3/64 1.3	3/64 1.0	1/32 0.8	5/8 16	19/64 7.5	25/64 10	25/32 20	0.25
69 03 130		5 1/8 130	✔ chrome plated	chrome	plastic coated	1/64 - 5/64 0.4 - 2.0	3/64 1.3	3/64 1.0	1/32 0.8	5/8 16	19/64 7.5	25/64 10	25/32 20	0.25

Exceptional cutting performance

- > induction hardened edges cut soft, hard and piano wire
- > cuts material like bolts, nails, rivets, etc. up to 1/4" (6.0 mm) dia.
- > exceptional cutting performance with minimum effort because of new lever action design
- > cutting edge hardness (approx. 64 HRC)
- > chrome vanadium heavy-duty steel; forged, multi stage oil-hardened

Micro-structured cutting edges allow easy cutting of large cross-sections

Gripping surface below the joint for gripping and pulling wires with a diameter from 3/64" (1 mm)

71 12 200

Opening spring and locking device are integrated in the handles for comfortable work and protected transport

71 02 200 T BKA*

Pliers with tether attachment point for tool drop protection system



Micro-structured cutting edges allow easy cutting of large cross-sections



With gripping surface below the joint for gripping and pulling wires with a diameter from 3/64"

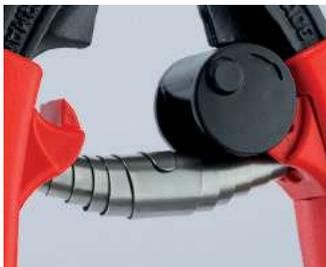

Opening spring and locking device are integrated in the handles for comfortable work and protected transport



71 01 160: High cutting force with a length of just 6 1/4" – ideal for small hands

60% less effort required

compared to conventional high leverage diagonal cutters. The lever-action mechanism ensures an extremely favorable lever ratio with very little friction. The cutting force is about 20 times higher than the handforce applied.



71 01 160



71 01 200



71 02 200



71 12 200

Product Number	Packaging	↔ Inch mm	Pliers	Handles	Cutting capacities				⚖️ lbs
					⊘ Inch ⊘ mm	⊘ Inch ⊘ mm	⊘ Inch ⊘ mm	⊘ Inch ⊘ mm	
71 01 160	X	6 1/4 160	▶▶	black atramentized plastic coated	13/64 5.3	11/64 4.4	1/8 3.2	1/8 3.0	0.43
71 01 200	X	8 200	▶▶	black atramentized plastic coated	1/4 6.0	13/64 5.2	5/32 4.0	9/64 3.6	0.74
71 02 200	X	8 200	▶▶	black atramentized slim multi-component grips	1/4 6.0	13/64 5.2	5/32 4.0	9/64 3.6	0.81
71 02 200 T BKA	X	8 200	▶▶	black atramentized slim multi-component grips, integrated tether attachment point	1/4 6.0	13/64 5.2	5/32 4.0	9/64 3.6	0.83
71 12 200	X	8 200	▶▶MM	black atramentized slim multi-component grips	1/4 6.0	13/64 5.2	5/32 4.0	9/64 3.6	0.84

The recess in the blade allows easier cutting of thicker wires, e.g. for anchor bolts in false ceilings

Gripping surface below the joint for gripping and pulling wires with a diameter from 3/64" (1 mm)

71 32 200 / 71 32 200 T BKA*

Opening spring and locking device are integrated in the handles for comfortable work and protected transport

71 32 200 T BKA*

Pliers with tether attachment point for tool drop protection system



71 31 200



Product Number	Packaging	↔ Inch mm	Icon	Pliers	Handles	Cutting capacities				⚖️ lbs
						⊘ Inch ⊘ mm	⊘ Inch ⊘ mm	⊘ Inch ⊘ mm	● Inch ● mm	
71 31 200	X	8 200	Icon	black atramentized	plastic coated	1/4 6.0	13/64 5.2	5/32 4.0	9/64 3.6	0.73
71 32 200		8 200	Icon	black atramentized	slim multi-component grips	1/4 6.0	13/64 5.2	5/32 4.0	9/64 3.6	0.82
71 32 200 T BKA	X	8 200	Icon	black atramentized	slim multi-component grips, integrated tether attachment point	1/4 6.0	13/64 5.2	5/32 4.0	9/64 3.6	0.84

20° angled head with single-sided joint bar and diagonal cutting edge for flush cutting; with space for gripping

71 22 200 / 71 22 200 T BKA*

Opening spring and locking device are integrated in the handles for comfortable work and protected transport

71 22 200 T BKA*

Pliers with tether attachment point for tool drop protection system

71 41 200

The recess in the blade allows easier cutting of thicker wires, e.g. for anchor bolts in false ceilings



71 22 200



Product Number	Packaging	↔ Inch mm	Icon	Pliers	Handles	Cutting capacities				⚖️ lbs
						⊘ Inch ⊘ mm	⊘ Inch ⊘ mm	⊘ Inch ⊘ mm	● Inch ● mm	
71 21 200	X	8 200	Icon	black atramentized	plastic coated	1/4 6.0	13/64 5.2	5/32 4.0	9/64 3.6	0.73
71 22 200	X	8 200	Icon	black atramentized	slim multi-component grips	1/4 6.0	13/64 5.2	5/32 4.0	9/64 3.6	0.82
71 22 200 T BKA	X	8 200	Icon	black atramentized	slim multi-component grips, integrated tether attachment point	1/4 6.0	13/64 5.2	5/32 4.0	9/64 3.6	0.83
71 41 200	X	8 200	Icon	black atramentized	plastic coated	1/4 6.0	13/64 5.2	5/32 4.0	9/64 3.6	0.73

KNIPEX CoBolt® XL

Compact Bolt Cutter

71

The compact bolt cutters from KNIPEX are now available with longer handles for one and two-handed operation.

Up to a 40-fold increase of manual force

For powerful cutting of larger diameters as well as very hard materials

Two-handed operation for maximum cutting force

- > 60% less effort required compared to high leverage diagonal cutters of the same size
- > 40-fold increase of manual force due to special joint design
- > gripping surface below the joint for gripping and pulling wires with a diameter from 3/64" (1 mm)
- > induction hardened precision blades: cutting edge hardness (approx. 64 HRC)
- > chrome vanadium heavy-duty steel; forged, multi stage oil-hardened



71 01 250



71 31 250



71 01 250

Straight blades

71 31 250

Blades with notch for easier cutting of larger diameters due to a better leverage close to the fulcrum

Product Number	Packaging	↔ Inch mm	Pliers	Handles	Cutting capacities			⚖ lbs	
					Ø Inch Ø mm	Ø Inch Ø mm	Ø Inch Ø mm		
71 01 250	X	10 250	✂	black atramentized	plastic coated	7/32 5.6	5/32 4.0	5/32 3.8	1.03
71 31 250	X	10 250	✂	black atramentized	plastic coated	1/4 6.0	11/64 4.3	11/64 4.2	1.03

KNIPEX CoBolt® "Fencing"

Compact Bolt Cutter

71

- > the CoBolt® with reduced cutting edge hardness to allow more pressure on the sides of the cutting edges (e.g. for making fences)
- > with precision cutting edges for soft and hard wire
- > cutting capacity: max. Ø 5/32" for hard wire (up to 1900 n/mm² / 48 HRC)
- > cuts material like bolts, nails, rivets, etc. up to 13/64" (5.2 mm) dia.
- > exceptional cutting performance with minimum effort because of new lever action design
- > induction hardened cutting edges (approx. 62 HRC)
- > chrome vanadium heavy-duty steel; forged, oil-hardened



71 01 200 R



71 31 200 R

The recess in the blade allows easier cutting of thicker wires, e.g. for false ceilings

Product Number	Packaging	↔ Inch mm	Pliers	Handles	Cutting capacities			⚖ lbs	
					Ø Inch Ø mm	Ø Inch Ø mm	Ø Inch Ø mm		
71 01 200 R	X	8 200	✂	black atramentized	plastic coated	15/64 6.0	13/64 5.2	5/32 4.0	0.74
71 31 200 R	X	8 200	✂	black atramentized	plastic coated	15/64 6.0	13/64 5.2	5/32 4.0	0.74

- > cutting capacity of steel up to 48 HRC
- > robust cutting edges with a hardness of (approx. 62 HRC)
- > forged-on stopper with comfortable shock absorber
- > good access due to very flat construction of head and joint area
- > ergonomically angled handles to minimize effort
- > sturdy, two-color dual component handles won't slip
- > precise adjustment (12 positions) by cam bolt
- > high cutting performance with minimum effort due to optimum coordination of the cutting edge angle and transmission ratio
- > bolted cutter head, replaceable
- > blade: chrome vanadium heavy-duty steel; forged, multi stage oil-hardened
- > joint: special tool steel; forged
- > handle: steel tube, powder-coated



71 72 460 71 72 610 71 72 760 71 72 910



Forged-on stopper with absorbing inserts:
cushions the cutting stroke

Product Number	Packaging	↔ Inch mm	Head	Handles	Cutting capacities			⚖️ lbs
					19 HRC Ø Inch Ø mm	40 HRC Ø Inch Ø mm	48 HRC Ø Inch Ø mm	
71 72 460		18 1/4 460	▶◀ grey a-tramentized	multi-component grips	5/16 8	15/64 6	13/64 5	4.59
71 72 610		24 610	▶◀ grey a-tramentized	multi-component grips	23/64 9	5/16 8	9/32 7	5.57
71 72 760		30 760	▶◀ grey a-tramentized	multi-component grips	7/16 11	23/64 9	5/16 8	9.40
71 72 910		35 3/4 910	▶◀ grey a-tramentized	multi-component grips	1/2 13	25/64 10	23/64 9	10.91
71 79 460	Spare cutter head for 71 72 460 complete with screws							
71 79 610	Spare cutter head for 71 72 610 complete with screws							
71 79 760	Spare cutter head for 71 72 760 complete with screws							
71 79 910	Spare cutter head for 71 72 910 complete with screws							

Concrete Mesh Cutter

71
82

The special shape of the mesh cutter head, 71 82 950, enable it to cut structural steel that is lying down flat

- > cutting capacity of steel up to 48 HRC hardness
- > robust cutting edges are induction hardened, cutting edge hardness (approx. 62 HRC)
- > forged-in stopper with comfortable shock-absorber
- > good access due to very flat construction of head and joint area
- > ergonomically angled handles to minimize effort
- > sturdy non-slip two-color dual component handle sleeves
- > precise adjustment (12 positions) by eccentric bolt
- > high cutting performance with minimum effort due to optimum coordination of the cutting edge angle and transmission ratio
- > bolted cutter head, replaceable
- > blade: chrome vanadium heavy-duty steel; forged, multi stage oil-hardened
- > joint: special tool steel, forged
- > handle: steel tube, powder-coated

71 82 950



Product Number	Packaging	↔ Inch mm	Head	Handles	Cutting capacities			⚖️ lbs
					19 HRC Ø Inch Ø mm	40 HRC Ø Inch Ø mm	48 HRC Ø Inch Ø mm	
71 82 950		41 13/32 950	 grey atramentized	multi-component grips	7/16 11	23/64 9	15/64 6	8.95
71 89 950	Spare cutter head for 71 82 950 complete with screws							

Diagonal Cutters

DIN ISO 5749

70

- > the essential cutting tool for all-around use
- > high-quality material and precise workmanship for long service life
- > precision cutting edges for soft and hard wire
- > clean cutting of thin copper wires, even at the cutting edge tips
- > induction hardened cutting edges (approx. 62 HRC)
- > narrow head style for use in confined areas
- > vanadium steel; forged, multi stage oil-hardened



Clean cutting of thin copper wires, also at the cutting edge tips



70 01 180



70 02 180



70 08 180 SBA



⚡ 1000 V ASTM



70 11 110



Product Number	Packaging	↔ Inch mm		Pliers	Head	Handles	Cutting capacities			⚖ lbs
							⊘ Inch Ø mm	⊘ Inch Ø mm	⊘ Inch Ø mm	
70 01 110		4 1/4 110					1/8 3.0	5/64 2.0	3/64 1.2	0.18
70 01 125		5 125	✓	black atramentized	polished3	plastic coated	1/8 3.0	3/32 2.3	1/16 1.5	0.18
70 01 140		5 1/2 140	✓				5/32 4.0	3/32 2.5	5/64 1.8	0.28
70 01 180		7 1/4 180					5/32 4.0	1/8 3.0	3/32 2.5	0.44
70 02 125		5 125					1/8 3.0	3/32 2.3	1/16 1.5	0.26
70 02 140		5 1/2 140	✓	black atramentized	polished	multi-component grips	5/32 4.0	3/32 2.5	5/64 1.8	0.35
70 02 180		7 1/4 180					5/32 4.0	1/8 3.0	3/32 2.5	0.57
70 08 180 SBA	X	7 1/4 180	⚡	1000 V ASTM	polished	insulated, multi-component handles, ASTM-tested	5/32 4.0	1/8 3.0	3/32 2.5	0.58
70 11 110		4 1/4 110	✓	black atramentized	polished	plastic coated	1/8 3.0	5/64 2.0	3/64 1.2	0.20

Diagonal Cutters

DIN ISO 5749

70

The next generation of the KNIPEX classic, with even better features

20% higher cutting force than the previous model, plus longer cutting edges

High cutting force due to optimum cutting geometry and transmission ratio

- > strong precision rivet for even movement and long service life
- > induction hardened cutting edges (approx. 62 HRC)
- > narrow head with long cutting edges: good access in confined areas
- > long tool life and high loading capacity
- > the essential diagonal cutters for diverse use
- > vanadium steel; forged, multi stage oil-hardened in multiple steps



70 01 160



70 02 160



70 08 160

1000 V ASTM



Product Number	Packaging	↔ Inch mm		Pliers	Head	Handles	Cutting capacities			
							⊘ Inch ⊘ mm	⊘ Inch ⊘ mm	⊘ Inch ⊘ mm	⚖ lbs
70 01 160	X	6 1/4 160		black atramentized	polished	plastic coated	5/32 4.0	1/8 3.0	5/64 2.0	0.40
70 02 160		6 1/4 160		black atramentized	polished	multi-component grips	5/32 4.0	1/8 3.0	5/64 2.0	0.47
70 08 160 SBA	X	6 1/4 160		black atramentized	polished	insulated, multi-component handles, ASTM-tested	5/32 4.0	1/8 3.2	5/64 2.0	0.49
70 26 160		6 1/4 160		chrome plated	chrome plated	insulated multi-component grips, VDE-tested	5/32 4.0	1/8 3.0	5/64 2.0	0.51

Flush Cutting Diagonal Pliers for Plastics

DIN ISO 5743

72

- > provides a fully flush cut when cutting tie-wraps, plastic and soft metals
- > for nearly flush cutting of molded plastic components from sprues
- > includes opening spring for easy repetitive work
- > vanadium electric steel; forged, oil-hardened

72 01 160

With elongated cutting edges; improved transmission ratio for 25% better cutting performance



72 01 160



72 02 125



72 11 160
 $\sphericalangle 45^\circ$



72 21 160
 $\sphericalangle 85^\circ$

Product Number	Packaging	\leftrightarrow Inch mm		Head	Handles	\sphericalangle lbs
72 01 140		5 1/2 140				0.28
72 01 160	X	6 1/4 160		polished	plastic coated	0.39
72 01 180		7 1/4 180				0.43
72 02 125		5 125		polished	multi-component grips	0.24
72 11 160	X	6 1/4 160	$\sphericalangle 45^\circ$	polished	plastic coated	0.38
72 21 160		6 1/4 160	$\sphericalangle 85^\circ$	polished	plastic coated	0.39

Diagonal Cutter for fiber optics

DIN ISO 5743

72

51

- > specially developed for cutting fiber optics (glass fiber cables)
- > with elongated cutting edges
- > cutting edges induction hardened
- > includes opening spring for easy repetitive work
- > vanadium steel; forged, multi stage oil-hardened



72 51 160

Product Number	Packaging	\leftrightarrow Inch mm		Head	Handles	\sphericalangle lbs
72 51 160		6 1/4 160		polished	plastic coated	0.38

High Leverage Flush Cutter for soft metal and plastic

72

For easy flush cutting of plastic components and soft metal

- > less effort for cutting thicker workpieces due to high leverage design
- > space for hands and flush cutting due to 20° angled head with joint bar on one side
- > opening spring and locking device are integrated in the handles
- > precision cutting edges, induction hardened (approx. 59 HRC) for soft materials
- > chrome vanadium electric steel, forged, multi stage oil-hardened



20°



View: Back of pliers



Materials are cut flush due to the almost bevel-free precision cutting edge

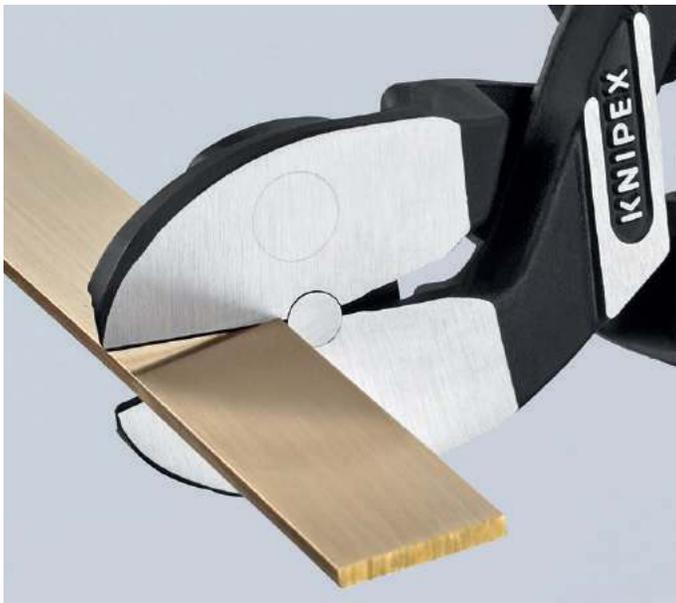

Copper busbars are cut cleanly and flush



Ideal for the flush cutting of plastic sprues with large diameters

Product Number	Packaging	↔ Inch mm		Pliers	Handles	⊘ Inch Ø mm	⚖ lbs
72 62 200	X	8 200	∠20°	black atramentized	with slim multi-component grips	1/4 6.0	0.83



KNIPEX

GERMANY

MADE IN

KNIPEX X-Cut®

Compact Diagonal Cutters, high lever transmission
DIN ISO 5749

73

Powerful, light and universal

Cuts fine strands as well as multi-stranded cables and piano wires

- > box-joint design: high stability and lightweight
- > high cutting performance with minimum effort due to optimum coordination of the cutting edge angle and transmission ratio
- > large opening width for thicker cables
- > cuts all wires precisely, even fine copper wires
- > compact, low weight construction
- > double supported joint axis for heavy-duty work
- > universal usage in the assembly, maintenance and production
- > chrome vanadium heavy-duty steel; forged, multi stage oil-hardened

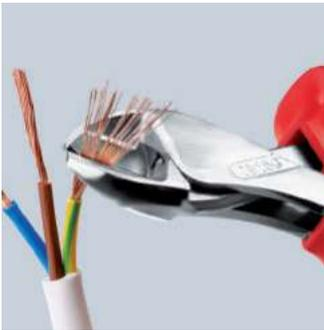

Box-joint design: high stability and lightweight



73 02 160



73 06 160

X-Cut®

40 % less effort required

compared with standard diagonal cutters of the same length.
With double mounted hinged joint.

Product Number	Packaging	↔ Inch mm		Pliers	Head	Handles	Cutting capacities					 lbs
							 Ø Inch Ø mm	 Ø Inch Ø mm	 Ø Inch Ø mm	 Ø Inch Ø mm	 Ø Inch Ø mm	
73 02 160	X	6 1/4 160		black atramentized	polished	multi-component grips	3/16 4.8	5/32 3.8	7/64 2.7	3/32 2.2	15/32 12.0	0.39
73 06 160		6 1/4 160		chrome plated	chrome plated	insulated, multi-component grips, VDE-tested	3/16 4.8	5/32 3.8	7/64 2.7	3/32 2.2	15/32 12.0	0.41

KNIPEX TwinForce®

High Leverage Diagonal Cutter

DIN ISO 5749

73

Superior high leverage diagonal cutter with patented double joint

- > ideal transmission of force due to double-hinged design
- > reliably cuts all types of wire, including steel tape
- > for rough or very fine cutting
- > for comfortable cutting, repetitive cutting or extremely hard cutting jobs
- > high degree of stability and zero backlash due to precisely milled forged-in axle
- > chrome vanadium heavy-duty steel; forged, oil-hardened



73 71 180



73 72 180



NEW for diagonal cutters:

The option to reapply the tool. The KNIPEX TwinForce® cuts even 5/32" (4 mm) thick wire without great effort when reapplied two or three times. Conventional high leverage diagonal cutters either cannot cut these diameters or only with very great effort.

Extremely easy cutting with little strain:

cuts 50% easier than KNIPEX high leverage diagonal cutters of the same size

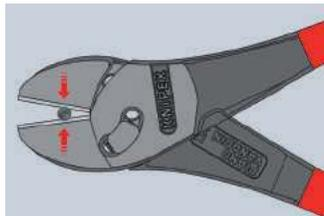

Insert the wires as close to the hinge as possible. In case of cutters with very high transmission, the width of the gap between the cutting edges close to the fulcrum may be less than the thickness of the wire. Wires may slip forward when the cutting starts.

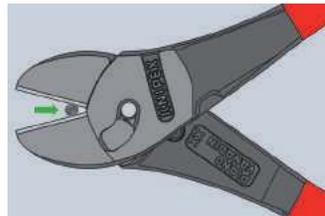

Continue cutting in the same location along the wire. Now cutting is much easier because the wire remains in place closer to the fulcrum.

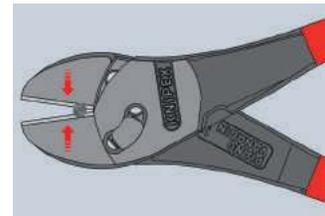

First make a notch in the wire using the KNIPEX TwinForce® until the required hand force increases considerably. Now open the pliers and slide the wire backwards towards the joint.

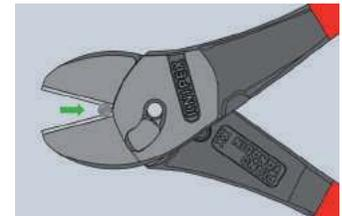

You can repeat this process if necessary.

TwinForce®

Product Number	Packaging	↔ Inch mm	Pliers	Head	Handles	Cutting capacities				⚖ lbs	
						Ø Inch Ø mm	Ø Inch Ø mm	Ø Inch Ø mm	Ø Inch Ø mm		
73 71 180	X	7 1/4 180	✓	black atramentized	polished	plastic coated	7/32 5.5	3/16 4.6	1/8 3.2	1/8 3.0	0.56
73 72 180 BK	X	7 1/4 180	✓	black atramentized	polished	multi-component grips	7/32 5.5	3/16 4.6	1/8 3.2	1/8 3.0	0.62

High Leverage Diagonal Cutters

DIN ISO 5749

74

- > forged-on axle for heavy-duty work
- > for very tough, continuous use
- > high performance with minimum effort due to optimum coordination of the cutting edge angle and transmission ratio
- > precision cutting edges induction hardened (approx. 64 HRC) cut several types of wire including piano wire
- > chrome vanadium heavy-duty steel; forged, multi stage oil-hardened

Style 1

With opening spring; can be activated if required

Style 2

Angled head offers clearance for gripping

10" Length (250 mm)

Suitable for copper conductors up to 16 mm² and aluminum conductors up to 35 mm²

74 02 200 T BKA / 74 02 250 T BKA / 74 22 200 T BKA / 74 22 250 T BKA*

Pliers with integrated tether attachment point for tool drop protection system

20% less effort required

compared to conventional diagonal cutters of the same length.
With forged-on joint axle.



74 12: Opening spring in deactivated position



74 12: Activated opening spring by pressing down with your thumb



74 01 200



74 02 250



74 02 250 T BKA



74 08 200 US

1000V ASTM



74 12 180



74 21 200

$\angle 12^\circ$



With integrated forged joint axle for very tough, continuous use

Product Number	Packaging	↔ Inch mm		Pliers	Head	Handles	Style	Cutting capacities			⚖️ lbs
								◐ Ø Inch Ø mm	◑ Ø Inch Ø mm	● Ø Inch Ø mm	
74 01 140		5 1/2 140					-	1/8 3.1	5/64 2.0	1/16 1.5	0.29
74 01 160	X	6 1/4 160					-	9/64 3.4	3/32 2.5	5/64 2.0	0.42
74 01 180	X	7 1/4 180	🟢	black atramentized	polished	plastic coated	-	5/32 3.8	7/64 2.7	3/32 2.2	0.53
74 01 200	X	8 200					-	11/64 4.2	1/8 3.0	3/32 2.5	0.58
74 01 250	X	10 250					-	3/16 4.6	9/64 3.5	1/8 3.0	0.90
74 02 140		5 1/2 140					-	1/8 3.1	5/64 2.0	1/16 1.5	0.35
74 02 160		6 1/4 160	🟢	black atramentized	polished	multi-component grips	-	9/64 3.4	3/32 2.5	5/64 2.0	0.49
74 02 180		7 1/4 180	🟢				-	5/32 3.8	7/64 2.7	3/32 2.2	0.60
74 02 200	X	8 200					-	11/64 4.2	1/8 3.0	3/32 2.5	0.66
74 02 200 T BKA	X	8 200	🟢	black atramentized	polished	multi-component grips, integrated tether attachment point	-	11/64 4.2	1/8 3.0	3/32 2.5	0.67
74 02 250	X	10 250	🟢	black atramentized	polished	multi-component grips	-	3/16 4.6	9/64 3.5	1/8 3.0	1.00
74 02 250 T BKA	X	10 250	🟢	black atramentized	polished	multi-component grips, integrated tether attachment point	-	3/16 4.6	9/64 3.5	1/8 3.0	1.01
74 08 200 US	X	8 200	🟢 ⚡ 1000 V ASTM	black atramentized	polished	insulated, multi-component handles, ASTM-tested	-	11/64 4.2	1/8 3.0	3/32 2.5	0.68
74 08 250 US	X	10 250					-	3/16 4.6	9/64 3.5	1/8 3.0	1.04
74 12 160		6 1/4 160	🟢	black atramentized	polished	multi-component grips	1	9/64 3.4	3/32 2.5	5/64 2.0	0.48
74 12 180		7 1/4 180	🟢				1	5/32 3.8	7/64 2.7	3/32 2.2	0.60
74 21 180		7 1/4 180					2	5/32 3.8	7/64 2.7	3/32 2.2	0.52
74 21 200	X	8 200	∠12° 🟢	black atramentized	polished	plastic coated	2	11/64 4.2	1/8 3.0	3/32 2.5	0.59
74 21 250	X	10 250					2	3/16 4.6	9/64 3.5	1/8 3.0	0.89
74 22 200	X	8 200	∠12° 🟢	black atramentized	polished	multi-component grips	2	11/64 4.2	1/8 3.0	3/32 2.5	0.67
74 22 200 T BKA	X	8 200	∠12° 🟢	black atramentized	polished	multi-component grips, integrated tether attachment point	2	11/64 4.2	1/8 3.0	3/32 2.5	0.68
74 22 250	X	10 250	∠12° 🟢	black atramentized	polished	multi-component grips	2	3/16 4.6	9/64 3.5	1/8 3.0	1.00
74 22 250 T BKA	X	10 250	∠12° 🟢	black atramentized	polished	multi-component grips, integrated tether attachment point	2	3/16 4.6	9/64 3.5	1/8 3.0	1.01

*Learn more about our tethered tool system on pages 207-211

High Leverage Center Cutters

DIN ISO 5743

74
91

- > forged-on axle for heavy-duty cutting
- > precision cutting edges for soft, hard and piano wire
- > cuts thick wires with less effort than other diagonal cutters of the same length
- > cutting edges are in the center of the cutter head
- > high cutting performance with minimum effort due to optimum coordination of the cutting edge angle and transmission ratio
- > cutting edge hardness (approx. 64 HRC)
- > chrome vanadium heavy-duty steel; forged, multi stage oil-hardened



Cutting edges in the center of the cutter head



74 91 250



Product Number	Packaging	↔ Inch mm	Pliers	Head	Handles	Cutting capacities				⚖️ lbs	
						Ø Inch Ø mm	Ø Inch Ø mm	Ø Inch Ø mm	Ø Inch Ø mm		
74 91 250	X	10 250	✂️	black atramentized	polished	plastic coated	13/64 5.0	13/64 5.0	5/32 3.8	9/64 3.5	0.87

Diagonal Cutters

for electromechanics

DIN ISO 5749

76

- > with sharp, precisely aligned cutting edges for soft, hard wire and piano wire
- > cutting edge hardness (approx. 63 HRC)
- > lap joint
- > vanadium steel; forged, multi stage oil-hardened in multiple steps

76 12 125

Low-friction double spring for gentle and even opening

76 22 125

Without bevel for flush cutting of soft wires;
low-friction double spring for gentle and even opening

76 81 125

Particularly tapered head with small bevel for work in confined areas (cable harnesses, multi-stranded wires)

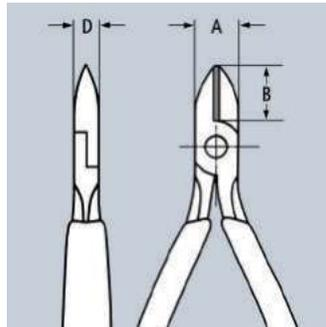

76 01 125



76 12 125



76 22 125



76 81 125



Product Number	Packaging	↔ Inch mm	Pliers	Head	Handles	Cutting capacities				Dimensions			⚖️ lbs	
						Ø Inch Ø mm	Ø Inch Ø mm	Ø Inch Ø mm	Ø Inch Ø mm	A Inch mm	B Inch mm	D Inch mm		
76 01 125		5 125	✂️	black atramentized	polished	plastic coated	1/64 - 1/8 0.4 - 3.0	3/32 2.3	1/16 1.5	1/32 0.6	37/64 14.5	5/8 16.0	23/64 9.0	0.20
76 12 125		5 125	✂️	black atramentized	polished	multi-component grips	1/64 - 3/32 0.4 - 2.5	5/64 1.8	3/64 1.0	1/32 0.6	37/64 14.5	5/8 16.0	23/64 9.0	0.25
76 22 125		5 125	✂️	black atramentized	polished	multi-component grips	1/64 - 3/32 0.4 - 2.5	-	-	-	37/64 14.5	5/8 16.0	23/64 9.0	0.24
76 81 125		5 125	✂️	black atramentized	polished	plastic coated	1/64 - 1/16 0.4 - 1.7	3/64 1.3	1/32 0.8	-	37/64 14.5	5/8 16.0	23/64 9.0	0.19

Electronics Oblique Cutting Nippers

DIN ISO 9654

62
12

- > cutting edges for soft and medium hard wire
- > without bevel; for flush cutting
- > cutting edge hardness (approx. 60 HRC)
- > low-friction double spring for gentle and even opening
- > precision box-joint
- > the polish and a fine film of oil offers effective rust protection – no circuit faults caused by peeling chrome from plated tools
- > ball bearing steel



62 12 120

Product Number	Packaging	↔ Inch mm	⊗ 15° MM	Head	Handles	Cutting capacities		Dimensions				⚖ lbs
						Ø Inch Ø mm	Ø Inch Ø mm	A Inch mm	B Inch mm	D Inch mm	C Inch mm	
62 12 120		4 3/4 120	⊗ 15° MM	polished	multi-component grips	1/64 - 3/64 0.3 - 1.0	1/32 0.7	7/16 11	25/64 10	19/64 7.5	43/64 17	0.21



- > precision pliers for ultra fine cutting work, e.g. in electronics and fine mechanics
- > precision box-joint
- > low-friction double spring for gentle and even opening
- > the mirror polish and fine film of oil offers effective rust protection – no circuit faults caused by peeling chrome from plated tools
- > cutting edge hardness (at least 60 HRC)
- > ball bearing steel, laser-hardened cutting edges

Style 0

End Cutter, with bevel

Style 2

End Cutter, mini-blade with small bevel

Style 3

Oblique End Cutter, short head, with small bevel, 15° angle

Style 4

Oblique End Cutter, short head, with small bevel, 27° angle

Style 5

Oblique End Cutter, short head, without bevel, for flush cutting, 27° angle

Style 6

Oblique End Cutter, mini-blade with small bevel, 65° angle, made of special tool steel, forged, oil-hardened

Style 7

Oblique End Cutter, mini-blade with small bevel, head with recess, 35° angle, made of special tool steel, forged, oil-hardened

Style 1 / 64 11 115

End Cutter, without bevel



64 02 115



64 12 115



64 22 115

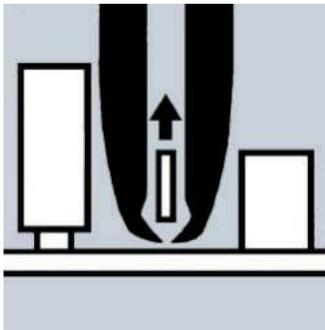

64 22 115

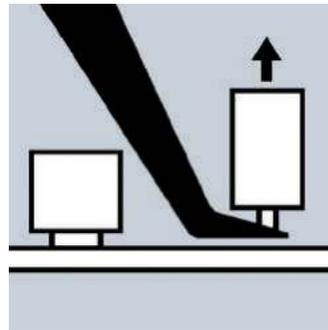

64 62 120



64 32 120



64 72 120

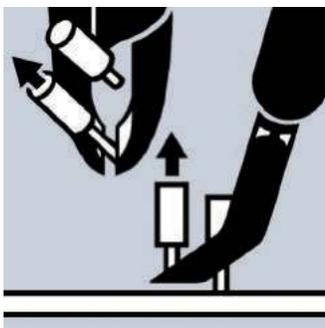

64 72 120

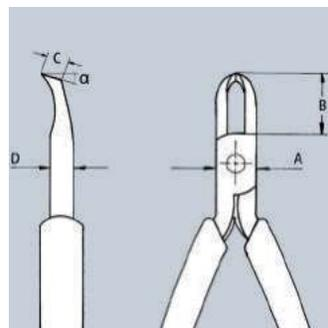

64 72 120



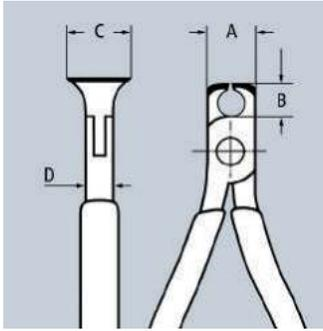

64 01/02/11/12

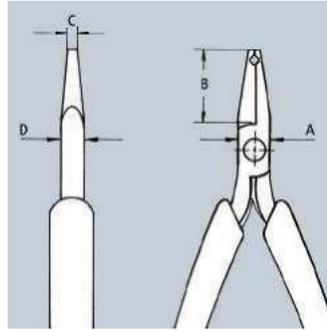

64 22 115

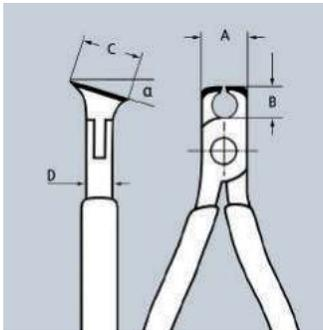

64 32/42/52

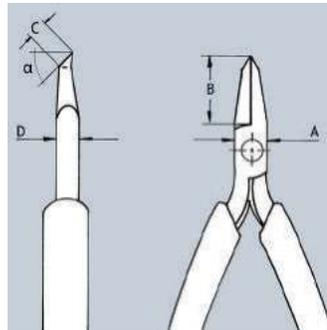

64 62 120



64 42 115
 $\angle 27^\circ$



64 52 115
 $\angle 27^\circ$



64 62 120
 $\angle 65^\circ$

Product Number	Packaging	↔ Inch mm	Head	Handles	Style	Cutting capacities			Dimensions				⚖ lbs	
						Ø Inch Ø mm	Ø Inch Ø mm	Ø Inch Ø mm	A Inch mm	B Inch mm	C Inch mm	D Inch mm		
64 01 115		4 1/2 115	$\angle 90^\circ$	mirror polished	plastic coated	0	5/64 2.0	3/64 1.0	1/64 0.5	7/16 11.0	15/64 6.0	5/8 16.0	19/64 7.5	0.17
64 02 115		4 1/2 115	$\angle 90^\circ$	mirror polished	multi-component grips	0	5/64 2.0	3/64 1.0	1/64 0.5	7/16 11.0	15/64 6.0	5/8 16.0	19/64 7.5	0.21
64 11 115		4 1/2 115	$\angle 90^\circ$	mirror polished	plastic coated	1	1/16 1.4	1/32 0.8	-	7/16 11.0	15/64 6.0	5/8 16.0	9/32 7.0	0.16
64 12 115		4 1/2 115	$\angle 90^\circ$	mirror polished	multi-component grips	1	1/16 1.4	1/32 0.8	-	7/16 11.0	15/64 6.0	5/8 16.0	9/32 7.0	0.21
64 22 115		4 1/2 115	$\angle 90^\circ$	mirror polished	multi-component grips	2	1/32 0.8	-	-	25/64 10.0	51/64 20.2	1/8 3.0	15/64 6.0	0.14
64 32 120		4 3/4 120	$\angle 15^\circ$	mirror polished	multi-component grips	3	1/16 1.5	3/64 1.0	1/64 0.5	7/16 11.0	25/64 10.0	43/64 17.0	9/32 7.0	0.20
64 42 115		4 1/2 115	$\angle 27^\circ$	mirror polished	multi-component grips	4	1/16 1.5	3/64 1.0	1/64 0.5	13/32 10.5	25/64 10.0	15/32 12.0	9/32 7.0	0.15
64 52 115		4 1/2 115	$\angle 27^\circ$	mirror polished	multi-component grips	5	3/64 1.3	-	-	13/32 10.5	25/64 10.0	15/32 12.0	9/32 7.0	0.15
64 62 120		4 3/4 120	$\angle 65^\circ$	mirror polished	multi-component grips	6	1/64 0.5	-	-	3/8 9.5	47/64 18.5	13/64 5.0	15/64 6.0	0.15
64 72 120		4 3/4 120	$\angle 35^\circ$	mirror polished	multi-component grips	7	1/16 1.5	-	-	15/32 12.0	13/64 5.1	13/64 5.0	9/32 7.0	0.21

- > precision pliers for ultra fine cutting work, e.g. in electronics and fine mechanics
- > electrically discharging handles – dissipative
- > precision box-joint
- > low-friction double spring for gentle and even opening
- > the mirror polish and a fine film of oil offers effective rust protection – no circuit faults caused by peeling chrome from plated tools
- > cutting edge hardness (at least 60 HRC)
- > with two-color dual component handles, black/grey
- > ball bearing chrome steel

Style 1
End Cutter, with small bevel

Style 3
Oblique End Cutter, short head, with small bevel, 15° angle

Style 6
Oblique End Cutter, mini-blade with small bevel, 65° angle



64 12 115 ESD
 $\angle 90^\circ$



64 32 120 ESD
 $\angle 15^\circ$

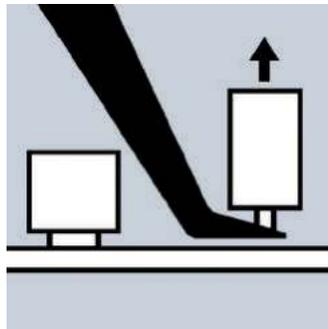

64 62 120 ESD

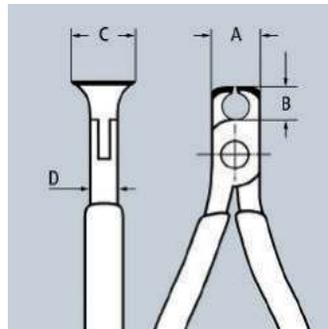

64 12 115 ESD



64 62 120 ESD
 $\angle 65^\circ$

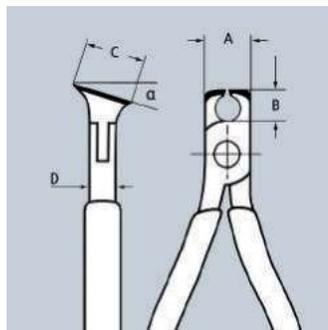

64 32 120 ESD

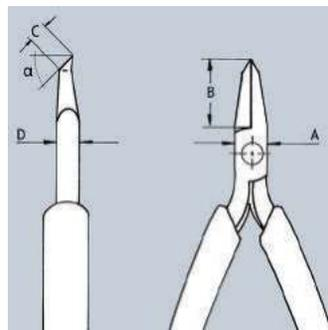

64 62 120 ESD

ESD Pliers (electrostatic discharge)

Electrostatic energy is discharged through the handles in a gradual and controlled manner which protects components endangered by electrostatic discharge in accordance with applicable standards, e.g. IEC TR 61 340-5, DIN EN 61 340-5, SP Method 2472



Product Number	Packaging	↔ Inch mm	\angle 	Head	Handles	Style	Cutting capacities			Dimensions				 lbs
							 Ø Inch Ø mm	 Ø Inch Ø mm	 Ø Inch Ø mm	A Inch mm	B Inch mm	C Inch mm	D Inch mm	
64 02 115 ESD		4 1/2 115	$\angle 90^\circ$	mirror polished	ESD multi-component grips	0	5/64 2.0	3/64 1.0	1/64 0.5	7/16 11.0	15/64 6.0	5/8 16.0	19/64 7.5	0.21
64 12 115 ESD		4 1/2 115	$\angle 90^\circ$	mirror polished	ESD multi-component grips	1	1/16 1.5	3/64 1.0	1/64 0.5	7/16 11.0	15/64 6.0	5/8 16.0	9/32 7.0	0.21
64 32 120 ESD		4 3/4 120	$\angle 15^\circ$	mirror polished	ESD multi-component grips	3	1/16 1.5	3/64 1.0	1/64 0.5	7/16 11.0	25/64 10.0	43/64 17.0	9/32 7.0	0.20
64 62 120 ESD		4 3/4 120	$\angle 65^\circ$	mirror polished	ESD multi-component grips	6	1/64 0.5	-	-	3/8 9.5	47/64 18.5	13/64 5.0	15/64 6.0	0.15

Electronics Diagonal Cutters

DIN ISO 9654

75

- > bolted joint for high precision and stress tolerance
- > for ultra fine cutting work, e.g. in electronics and fine mechanics
- > sharp, ground cutting edges for soft, hard wire and piano wire
- > cutting edge hardness (approx. 64 HRC)
- > low-friction double spring for gentle and even opening
- > high-grade special tool steel; forged, multi stage oil-hardened

Style 0

With bevel

Style 1

With bevel and lead catcher, no uncontrolled loss of cut wire ends

Style 2

With small bevel

Style 3

Particularly narrow head, with bevel



Bolted joint

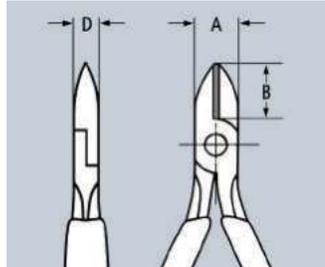

75 02 125



75 12 125



75 22 125



75 52 125

WARNING: This product can expose you to chemicals including Diisononyl Phthalate, which is known to the State of California to cause cancer. For more information go to www.P65Warnings.ca.gov

Product Number	Packaging	↔ Inch mm		Style	Pliers	Handles	Cutting capacities				Dimensions			⚖ lbs
							Ø Inch Ø mm	Ø Inch Ø mm	Ø Inch Ø mm	Ø Inch Ø mm	A Inch mm	B Inch mm	D Inch mm	
75 02 125		5 125		0	burnished	plastic grips	1/64 - 3/64 0.2 - 1.3	3/64 1.0	1/32 0.6	1/64 0.4	13/32 10.5	35/64 14	1/4 6.5	0.18
75 12 125		5 125		1	burnished	plastic grips	1/64 - 3/64 0.2 - 1.3	3/64 1.0	1/32 0.6	1/64 0.4	13/32 10.5	35/64 14	1/4 6.5	0.18
75 22 125		5 125		2	burnished	plastic grips	1/64 - 3/64 0.2 - 1.3	1/32 0.9	1/64 0.4	1/64 0.3	13/32 10.5	35/64 14	1/4 6.5	0.18
75 52 125		5 125		3	burnished	plastic grips	1/64 - 1/32 0.2 - 0.8	1/64 0.5	1/64 0.3	-	13/32 10.5	35/64 14	1/4 6.5	0.18

Electronics Diagonal Cutters

DIN ISO 9654

77

- > for fine cutting work in electronics and fine mechanics
- > sturdy, zero backlash box-joint
- > low-friction double spring for gentle and even opening
- > mirror polish, with a fine film of oil, offers effective rust protection – no circuit faults caused by peeling chrome from plated tools
- > cutting edges induction hardened (approx. 60 HRC)
- > ball bearing steel

77 01 115 / 77 02 130 / 77 01 130
Round head, with bevel; cutting edge hardness approx. 62 HRC

77 02 115 / 77 22 130
Round head, with small bevel; cutting edge hardness approx. 60 HRC

77 12 115
Round head, with bevel and lead catcher – no uncontrolled loss of cut wire ends; cutting edge hardness approx. 62 HRC

77 21 115
Pointed head, without bevel; cutting edge hardness approx. 57 HRC

77 22 115
Round head, without bevel; cutting edge hardness approx. 57 HRC

77 32 115
Pointed head, with small bevel; cutting edge hardness approx. 60 HRC

77 42 115 / 77 42 130
Pointed head, without bevel; cutting edge hardness approx. 57 HRC

77 52 115
Pointed, flat head, with small bevel; cutting edge hardness approx. 60 HRC

77 72 115
Pointed mini-head, with small bevel; cutting edge hardness approx. 60 HRC

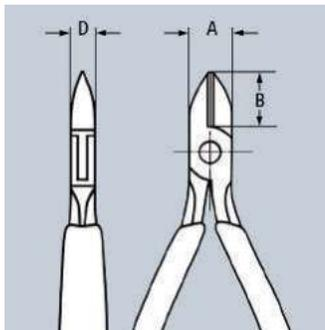

77 01 115
✳️   



77 02 115
✳️   



77 12 115
✳️    



77 41 115
✳️   

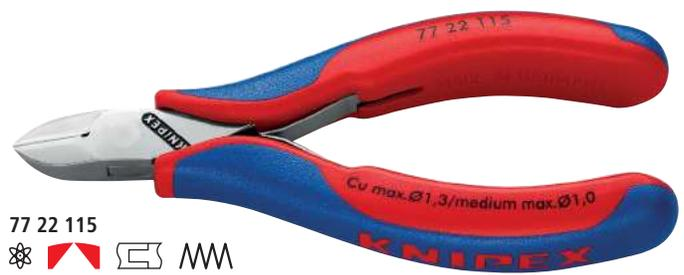

77 22 115
✳️   



77 32 115



77 52 115



77 42 115



77 72 115

Product Number	Packaging	↔ Inch mm		Head	Handles	Cutting capacities			Dimensions			 lbs
						 Ø Inch Ø mm	 Ø Inch Ø mm	 Ø Inch Ø mm	A Inch mm	B Inch mm	D Inch mm	
77 01 115		4 1/2 115		mirror polished	plastic coated	1/64 - 1/16 0.3 - 1.6	3/64 1.2	1/64 0.3	7/16 11.0	35/64 14.0	19/64 7.5	0.15
77 01 130		5 1/4 130		mirror polished	plastic coated	1/64 - 5/64 0.3 - 2.0	1/16 1.5	1/32 0.8	19/32 15.0	23/32 18.3	3/8 9.5	0.24
77 02 115		4 1/2 115		mirror polished	multi-component grips	1/64 - 1/16 0.3 - 1.6	3/64 1.2	1/64 0.3	7/16 11.0	35/64 14.0	19/64 7.5	0.18
77 02 130		5 1/4 130		mirror polished	multi-component grips	1/64 - 5/64 0.3 - 2.0	1/16 1.5	1/32 0.8	19/32 15.0	23/32 18.3	3/8 9.5	0.30
77 11 115		4 1/2 115		mirror polished	single-component grips	1/64 - 1/16 0.3 - 1.6	3/64 1.2	1/64 0.3	7/16 11.0	35/64 14.0	19/64 7.5	0.18
77 12 115		4 1/2 115		mirror polished	multi-component grips	1/64 - 1/16 0.3 - 1.6	3/64 1.2	1/64 0.3	35/64 14.0	7/16 11.0	19/64 7.5	0.18
77 21 115 N		4 1/2 115		mirror polished	single-component grips	1/64 - 3/64 0.3 - 1.3	3/64 1.0	-	7/16 11.0	33/64 10.3	9/32 7.0	0.11
77 21 130		5 1/4 130		mirror polished	single-component grips	1/64 - 1/16 0.3 - 1.6	3/64 1.2	-	19/32 15.0	23/32 18.3	3/8 9.5	0.30
77 22 115		4 1/2 115		mirror polished	multi-component grips	1/64 - 3/64 0.3 - 1.3	3/64 1.0	-	7/16 11.0	35/64 14.0	9/32 7.0	0.18
77 22 130		5 1/4 130		mirror polished	multi-component grips	1/64 - 5/64 0.3 - 2.0	1/16 1.5	-	19/32 15.0	23/32 18.3	23/64 9.0	0.27
77 32 115		4 1/2 115		mirror polished	multi-component grips	1/64 - 3/64 0.3 - 1.3	3/64 1.0	1/64 0.5	7/16 11.0	35/64 14.0	19/64 7.5	0.18
77 41 115		4 1/2 115		mirror polished	plastic coated	1/64 - 3/64 0.3 - 1.3	1/32 0.8	-	35/64 14.0	1/2 13.0	19/64 7.5	0.18
77 42 115		4 1/2 115		mirror polished	multi-component grips	1/64 - 3/64 0.3 - 1.3	1/32 0.8	-	7/16 11.0	35/64 14.0	19/64 7.5	0.18
77 42 130		5 1/4 130		mirror polished	multi-component grips	1/64 - 1/16 0.3 - 1.6	3/64 1.3	-	19/32 15.0	23/32 18.3	3/8 9.5	0.18
77 52 115		4 1/2 115		mirror polished	multi-component grips	1/64 - 3/64 0.3 - 1.0	1/32 0.8	1/64 0.5	7/16 11.0	35/64 14.0	19/64 7.5	0.17
77 72 115		4 1/2 115		mirror polished	multi-component grips	1/64 - 1/32 0.3 - 0.8	-	-	3/8 9.5	13/32 10.5	15/64 6.0	0.15

- > for fine cutting work in electronics and fine mechanics
- > electrically discharging handles – dissipative
- > sturdy, zero backlash box-joint
- > low-friction double spring for gentle and even opening
- > the mirror polish with a fine film of oil, offers effective rust protection – no circuit faults caused by peeling chrome from plated tools
- > induction hardened cutting edges (approx. 60 HRC)
- > ball bearing steel

77 02 115 ESD

Round head, with small bevel; cutting edge hardness approx. 60 HRC

77 12 115 ESD

Round head, with bevel and lead catcher - no uncontrolled loss of cut wire ends; cutting edge hardness approx. 62 HRC

77 22 115 ESD

Round head, without bevel; cutting edge hardness approx. 57 HRC

77 32 115 ESD

Pointed head, with small bevel; cutting edge hardness approx. 60 HRC

77 42 115 ESD

Pointed head, without bevel; cutting edge hardness approx. 57 HRC

77 52 115 ESD

Pointed, flat head, with small bevel; cutting edge hardness approx. 60 HRC

77 72 115 ESD

Pointed mini-head, with small bevel; cutting edge hardness approx. 60 HRC



77 02 115 ESD



77 12 115 ESD



77 22 115 ESD



77 32 115 ESD

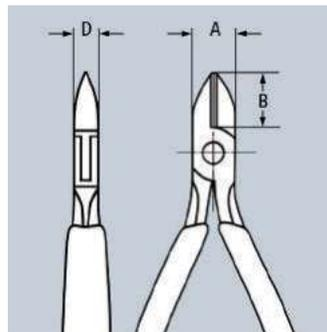

ESD Pliers (electrostatic discharge)

Electrostatic energy is discharged through the handles in a gradual and controlled manner which protects components endangered by electrostatic discharge in accordance with applicable standards, e.g. IEC TR 61 340-5, DIN EN 61 340-5, SP Method 2472





77 42 115 ESD



77 52 115 ESD



77 72 115 ESD

Product Number	Packaging	↔ Inch mm		Head	Handles	Cutting capacities			Dimensions			 lbs
						 Ø Inch Ø mm	 Ø Inch Ø mm	 Ø Inch Ø mm	A Inch mm	B Inch mm	D Inch mm	
77 02 115 ESD		4 1/2 115		mirror polished	ESD multi-component grips	1/64 - 1/16 0.3 - 1.6	3/64 1.2	1/64 0.3	7/16 11.0	35/64 14.0	19/64 7.5	0.16
77 12 115 ESD		4 1/2 115		mirror polished	ESD multi-component grips	1/64 - 1/16 0.3 - 1.6	3/64 1.2	1/32 0.6	7/16 11.0	35/64 14.0	19/64 7.5	0.18
77 22 115 ESD		4 1/2 115		mirror polished	ESD multi-component grips	1/64 - 3/64 0.3 - 1.3	3/64 1.0	-	7/16 11.0	35/64 14.0	19/64 7.5	0.15
77 32 115 ESD		4 1/2 115		mirror polished	ESD multi-component grips	1/64 - 3/64 0.3 - 1.3	3/64 1.0	1/64 0.5	7/16 11.0	35/64 14.0	19/64 7.5	0.17
77 42 115 ESD		4 1/2 115		mirror polished	ESD multi-component grips	1/64 - 3/64 0.3 - 1.3	1/32 0.8	-	7/16 11.0	35/64 14.0	19/64 7.5	0.17
77 52 115 ESD		4 1/2 115		mirror polished	ESD multi-component grips	1/64 - 3/64 0.3 - 1.0	1/32 0.8	1/64 0.5	7/16 11.0	35/64 14.0	19/64 7.5	0.17
77 72 115 ESD		4 1/2 115		mirror polished	ESD multi-component grips	1/64 - 1/32 0.3 - 0.8	-	-	7/16 11.0	35/64 14.0	19/64 7.5	0.15

Electronics Diagonal Cutters

with inserted carbide metal cutting edges

DIN ISO 9654

77
H

- > for extreme demands on cutting pliers caused by hard or tough materials, e.g. piano, nickel, tungsten and diode wire, which are used more frequently in the electronics and aerospace industries
- > precision carbide metal cutting edges soldered into forged blanks
- > sturdy, zero backlash box-joint
- > hardness of the carbide cutting edges (approx. 80 – 83 HRC)
- > pliers with carbide metal cutting edges have a substantially longer service life than with conventional cutting edges
- > constantly reliable cutting results due to the avoidance of cutter deformations
- > high cost savings due to longer service life of the pliers

77 32 120 H

Pointed head with chamfer; with small bevel

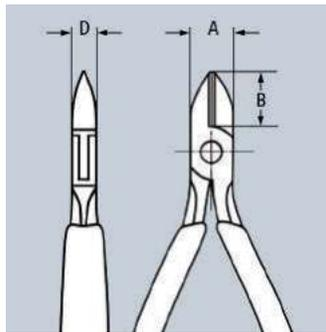
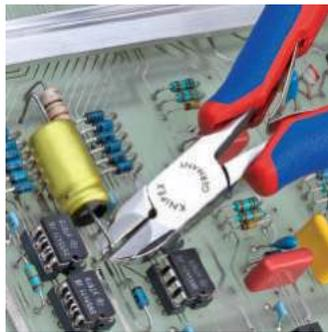

77 02 120 H



77 32 120 H



Inserted Carbide Cutting Edges

Precision carbide metal cutting edges soldered into forged blanks

Product Number	Packaging	↕ Inch mm	Icon	Head	Handles	Cutting capacities				Dimensions			⚖ lbs
						Ø Inch Ø mm	Ø Inch Ø mm	Ø Inch Ø mm	Ø Inch Ø mm	A Inch mm	B Inch mm	D Inch mm	
77 02 120 H		4 3/4 120	Icon	mirror polished	multi-component grips	5/64	3/64	1/32	1/64	7/16	9/16	19/64	0.19
						2.0	1.0	0.6	0.2	11	14.3	7.5	
77 02 135 H		5 1/4 135	Icon	mirror polished	multi-component grips	5/64	1/16	3/64	1/32	19/32	45/64	3/8	0.26
						2.0	1.6	1.2	0.8	15	18	9.5	
77 32 120 H		4 3/4 120	Icon	mirror polished	multi-component grips	1/16	1/32	1/64	1/64	7/16	9/16	19/64	0.17
						1.6	0.6	0.2	0.2	11	14.3	7.5	

Electronics Diagonal Cutters ESD

with inserted carbide metal cutting edges

DIN ISO 9654

77
H

- > for extreme demands on cutting pliers caused by hard or tough materials, e.g. piano, nickel, tungsten and diode wire, which are used more frequently in the electronics and aerospace industries
- > precision carbide metal cutting edges soldered into forged blanks
- > sturdy, zero backlash box-joint
- > hardness of the carbide cutting edges (approx. 80 – 83 HRC)
- > pliers with carbide metal cutting edges have a substantially longer service life than those with conventional cutting edges
- > constantly reliable cutting results due to the avoidance of cutter deformations
- > high cost savings due to longer service life of the pliers
- > electrically discharging handles – dissipative (ESD version only)

77 32 120 H ESD

Pointed head with chamfer; with small bevel

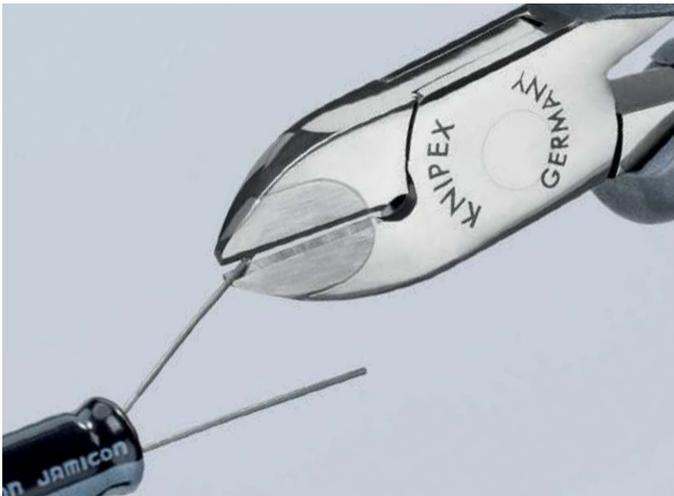
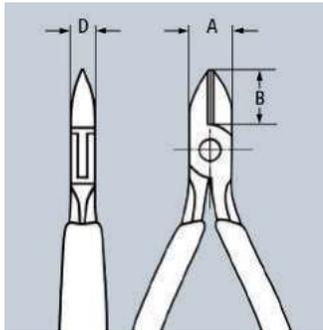

77 02 120 H ESD



77 02 135 H ESD



ESD Pliers (electrostatic discharge)

Electrostatic energy is discharged through the handles in a gradual and controlled manner which protects components endangered by electrostatic discharge in accordance with applicable standards, e.g. IEC TR 61 340-5, DIN EN 61 340-5, SP Method 2472



Product Number	Packaging	↔ Inch mm	Icons	Head	Handles	Cutting capacities				Dimensions			⚖ lbs
						Ø Inch Ø mm	Ø Inch Ø mm	Ø Inch Ø mm	Ø Inch Ø mm	A Inch mm	B Inch mm	D Inch mm	
77 02 120 H ESD		4 3/4 120	⚡ ⚙ ⚡	mirror polished	ESD multi-component grips	5/64 2.0	3/64 1.0	1/32 0.6	1/64 0.2	7/16 11.0	9/16 14.3	19/64 7.5	0.19
77 02 135 H ESD		5 1/4 135	⚡ ⚙ ⚡	mirror polished	ESD multi-component grips	5/64 2.0	1/16 1.6	3/64 1.2	1/32 0.8	19/32 15.0	45/64 18.0	3/8 9.5	0.26
77 32 120 H ESD		4 3/4 120	⚡ ⚙ ⚡	mirror polished	ESD multi-component grips	1/16 1.6	1/32 0.6	1/64 0.2	1/64 0.2	7/16 11.0	9/16 14.3	19/64 7.5	0.17

- > precision pliers for ultra fine cutting work in electronics and fine mechanics
- > ground, very sharp cutting edges without bevel for flush cutting
- > precision shaped tips cut wires resting on a board from 1/64" (0.2 mm) dia.
- > joint with stainless steel rivet
- > extremely smooth movement for minimum operator fatigue
- > includes opening spring for easy repetitive work

78 03 125 / 78 23 125

Cutting edge hardness approx. 54 HRC; INOX – stainless steel

78 13 125

With lead catcher – no uncontrolled loss of cut wire ends; cutting edge hardness approx. 54 HRC; INOX – stainless steel

78 31 125

With narrow head; cutting edge hardness approx. 60 HRC; special tool steel, burnished

78 41 125

With lead catcher – no uncontrolled loss of cut wire ends; with narrow head; cutting edge hardness approx. 60 HRC; special tool steel, burnished

78 61 125

Suitable for cutting glass fiber cables (fiber optics); cutting edge hardness approx. 64 HRC; special tool steel, multi stage oil-hardened

78 71 125

With lead catcher – no uncontrolled loss of cut wire ends; cutting edge hardness approx. 64 HRC; special tool steel, burnished

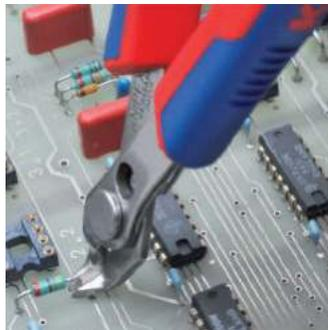

78 03 125
✂  



78 13 125
✂   



78 23 125
✂ $\angle 60^\circ$  



78 31 125
✂  



78 41 125
✂   

Models for hard wire

78 81 125

Precision ground cutting edges with very small bevel suitable for hard wire; cutting edge hardness approx. 64 HRC; special tool steel, burnished

78 91 125

Precision ground cutting edges with very small bevel suitable for hard wire; with lead catcher – no uncontrolled loss of cut wire ends; cutting edge hardness approx. 64 HRC; special tool steel, burnished

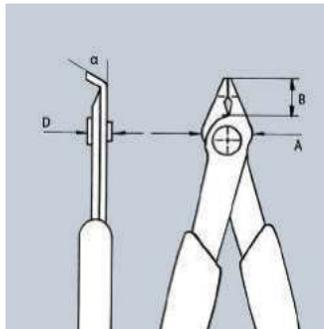
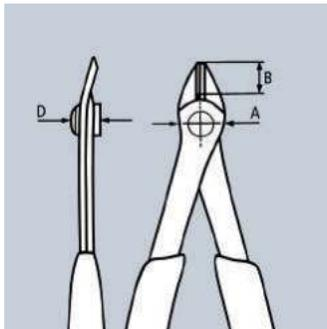
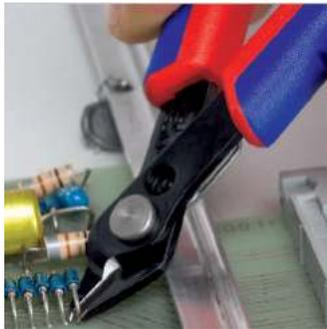

78 61 125



78 71 125



78 81 125



78 91 125

Product Number	Packaging	↔ Inch mm	Pliers	Head	Handles	Cutting capacities			Dimensions			⚖️ lbs
						☉ Ø Inch Ø mm	☉ Ø Inch Ø mm	☉ Ø Inch Ø mm	A Inch mm	B Inch mm	D Inch mm	
78 03 125		5 125		polished	multi-component grips	1/64 - 1/16 0.2 - 1.6	3/64 1.0	-	17/32 13.5	23/64 9.0	19/64 7.5	0.13
78 13 125		5 125		polished	multi-component grips	1/64 - 1/16 0.2 - 1.6	3/64 1.0	-	17/32 13.5	23/64 9.0	19/64 7.5	0.14
78 23 125	X	5 125		polished	multi-component grips	1/64 - 3/64 0.2 - 1.0	1/64 0.2	-	17/32 13.5	7/32 5.5	19/64 7.5	0.12
78 31 125		5 125		burnished	multi-component grips	1/64 - 3/64 0.2 - 1.0	-	-	17/32 13.5	23/64 9.0	19/64 7.5	0.13
78 41 125		5 125		burnished	multi-component grips	1/64 - 3/64 0.2 - 1.0	-	-	17/32 13.5	23/64 9.0	19/64 7.5	0.14
78 61 125	X	5 125		burnished	multi-component grips	1/64 - 1/16 0.2 - 1.6	3/64 1.2	-	17/32 13.5	23/64 9.0	19/64 7.5	0.13
78 71 125		5 125		burnished	multi-component grips	1/64 - 1/16 0.2 - 1.6	3/64 1.2	-	17/32 13.5	23/64 9.0	19/64 7.5	0.14
78 81 125		5 125		burnished	multi-component grips	5/64 - 1/16 1.2 - 1.6	3/64 1.2	1/64 0.2	17/32 13.5	23/64 9.0	19/64 7.5	0.14
78 91 125		5 125		burnished	multi-component grips	5/64 - 1/16 1.2 - 1.6	3/64 1.2	1/64 0.2	17/32 13.5	23/64 9.0	19/64 7.5	0.14

- > precision pliers for ultra fine cutting work in electronics and fine mechanics
- > electrically discharging handles – dissipative (ESD versions only)
- > ground, very sharp cutting edges without bevel for flush cutting
- > precision shaped tips cut wires resting on a board from 1/64" (0.2 mm) dia.
- > joint with stainless steel rivet
- > extremely smooth movement for minimum operator fatigue
- > includes opening spring for easy repetitive work

78 03 125 ESD

Cutting edge hardness approx. 54 HRC; INOX – stainless steel

78 13 125 ESD

With lead catcher – no uncontrolled loss of cut wire ends; cutting edge hardness approx. 54 HRC; INOX – stainless steel

78 61 125 ESD

Cutting edge hardness approx. 64 HRC; special tool steel, burnished

78 71 125 ESD

With lead catcher – no uncontrolled loss of cut wire ends; cutting edge hardness approx. 64 HRC; special tool steel, burnished



78 03 125 ESD
⚠ ⚡ ⚠ ⚠



78 13 125 ESD
⚠ ⚡ ⚠ ⚠



78 61 125 ESD
⚠ ⚡ ⚠ ⚠



78 71 125 ESD
⚠ ⚡ ⚠ ⚠

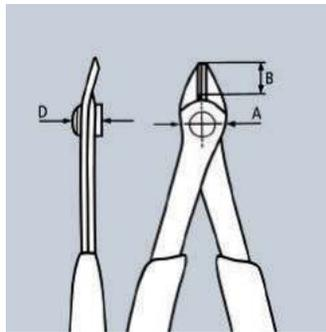

ESD Pliers (electrostatic discharge)

Electrostatic energy is discharged through the handles in a gradual and controlled manner which protects components endangered by electrostatic discharge in accordance with applicable standards, e.g. IEC TR 61 340-5, DIN EN 61 340-5, SP Method 2472



Product Number	Packaging	↔ Inch mm	⚠ ⚡ ⚠ ⚠	Head	Handles	Cutting capacities		Dimensions			⚖ lbs
						⊘ Inch ⊘ mm	⊘ Inch ⊘ mm	A Inch mm	B Inch mm	D Inch mm	
78 03 125 ESD		5 125	⚠ ⚡ ⚠ ⚠	polished	ESD multi-component grips	1/64 - 1/16 0.2 - 1.6	3/64 1.0	17/32 13.5	23/64 9.0	19/64 7.5	0.13
78 13 125 ESD		5 125	⚠ ⚡ ⚠ ⚠	polished	ESD multi-component grips	1/64 - 1/16 0.2 - 1.6	3/64 1.0	17/32 13.5	23/64 9.0	19/64 7.5	0.14
78 61 125 ESD		5 125	⚠ ⚡ ⚠ ⚠	burnished	ESD multi-component grips	1/64 - 1/16 0.2 - 1.6	3/64 1.2	17/32 13.5	23/64 9.0	19/64 7.5	0.12
78 71 125 ESD		5 125	⚠ ⚡ ⚠ ⚠	burnished	ESD multi-component grips	1/64 - 1/16 0.2 - 1.6	3/64 1.2	17/32 13.5	23/64 9.0	19/64 7.5	0.14

Now available in a 5 1/2" version. The added 1/2" length is for greater stability and cutting performance.

- > precision ground cutting edges without bevel for flush cutting the finest of wires e.g. in electronics and precision engineering
- > precisely shaped tips also cut adjacent wires from 1/64" (0.20 mm) diameter
- > opening spring and opening limiter user-friendly handle width
- > extremely smooth movement for minimum operator fatigue

78 03 140 / 78 03 140 ESD

Durable and stainless, made from INOX surgical steel, cutting edges hardened to 54 HRC

78 61 140 / 78 61 140 ESD

Heavy-duty, made from burnished special tool steel, cutting edges induction hardened (approx. 64 HRC)

78 03 140 ESD / 78 61 140 ESD

Allows electrostatic energy to discharge through the handles protecting components from electrostatic discharge



78 03 140



78 61 140 ESD



5 1/2" (140 mm) length: stronger and extremely versatile



For flush cutting, e.g. to shorten cable ties



Shear cut blade design for precise cutting

Product Number	Packaging	↔ Inch mm		Head	Handles	⊙ Ø Inch Ø mm	⊙ Ø Inch Ø mm	A Inch mm	B Inch mm	D Inch mm	⚖ lbs
78 03 140		5 1/2 140	▲	polished	multi-component grips	1/64 - 1/8 0.2 - 2.1	1/16 1.2	39/64 15.5	31/64 12.5	23/64 13.5	0.17
78 03 140 ESD		5 1/2 140	▲	polished	ESD multi-component grips	1/64 - 1/8 0.2 - 2.1	1/16 1.2	39/64 15.5	31/64 12.5	23/64 13.5	0.17
78 61 140		5 1/2 140	▲ ⚠		multi-component grips	1/64 - 1/8 0.2 - 2.1	1/16 1.2	39/64 15.5	31/64 12.5	23/64 13.5	0.17
78 61 140 ESD		5 1/2 140	▲ ⚠		ESD multi-component grips	1/64 - 1/8 0.2 - 2.1	1/16 1.2	39/64 15.5	31/64 12.5	23/64 13.5	0.17

- > precision pliers for ultra fine cutting work in electronics and fine mechanics
- > very precisely ground and sharp cutting edges with very small bevels for precise cutting work on small electronic components
- > cutting edge hardness (approx. 64 HRC)
- > approx. 20% lighter than conventional electronics pliers
- > bolted joint with carefully manufactured joint surfaces for even, low-friction movement throughout the entire opening range
- > double spring for a gentle and even opening
- > ergonomically optimized handle covers
- > ball bearing chrome steel; forged, multi stage oil-hardened

79 02 120
Mini-head

79 02 125
Round head

79 12 125
Specifically for cutting through hard wire and piano wire

79 22 120
Mini-head

79 22 125
Round head

79 32 125
Pointed head

79 42 125
Pointed head

79 52 125
Pointed head; with lead catcher – no uncontrolled loss of cut wire ends

79 62 125
Pointed head; with lead catcher – no uncontrolled loss of cut wire ends



Cut with
79 42 125
(without bevel)

Cut with
79 42 125 Z
(flush cut)

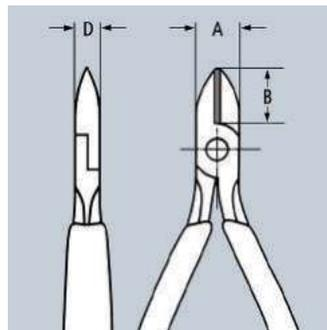

79 02 120
✂️



79 02 125
✂️



79 22 120
✂️



79 22 125
✂️



79 32 125
✂️

The Subtle Difference

KNIPEX precision electronics pliers are made of high-quality ball bearing steel and processed with the highest degree of care. Each opening movement is gentle and even without backlash. Each work step proceeds reliably and precisely. This makes work much easier for professionals.



79 42 125



79 42 125 Z

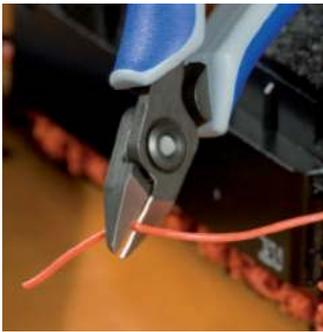

Product Number	Packaging	↔ Inch mm					Pliers	Head	Handles	Cutting capacities				Dimensions			⚖ lbs
										⊘ Inch Ø mm	⊘ Inch Ø mm	⊘ Inch Ø mm	⊘ Inch Ø mm	A Inch mm	B Inch mm	D Inch mm	
79 02 120		4 3/4 120					burnished	polished	multi-component grips	1/64 - 1/16 0.2 - 1.4	3/64 1.0	1/64 0.2	-	23/64 9.0	1/4 6.5	1/4 6.5	0.13
79 02 125		5 125					burnished	polished	multi-component grips	1/64 - 5/64 0.2 - 1.2	3/64 1.3	1/32 0.7	-	7/16 11.0	25/64 10.0	1/4 6.5	0.13
79 12 125		5 125					burnished	polished	multi-component grips	1/64 - 5/64 0.3 - 1.2	3/64 1.3	3/64 1.0	1/64 0.2	7/16 11.0	25/64 10.0	1/4 6.5	0.13
79 22 120		4 3/4 120					burnished	polished	multi-component grips	1/64 - 3/64 0.1 - 1.3	1/32 0.8	-	-	23/64 9.0	1/4 6.5	1/4 6.5	0.13
79 22 125		5 125					burnished	polished	multi-component grips	1/64 - 5/64 0.1 - 1.2	3/64 1.0	-	-	7/16 11.0	25/64 10.0	1/4 6.5	0.13
79 32 125		5 125					burnished	polished	multi-component grips	1/64 - 1/16 0.2 - 1.5	3/64 1.1	1/64 0.2	-	7/16 11.0	7/16 11.0	1/4 6.5	0.13
79 42 125		5 125					burnished	polished	multi-component grips	1/64 - 1/16 0.1 - 1.5	1/32 0.8	-	-	7/16 11.0	7/16 11.0	1/4 6.5	0.13
79 42 125 Z		5 125					burnished	polished	multi-component grips	up to 1/64 up to 0.2	-	-	-	7/16 11.0	7/16 11.0	1/4 6.5	0.13
79 52 125		5 125					burnished	polished	multi-component grips	1/64 - 1/16 0.2 - 1.7	1/32 0.9	1/64 0.5	-	7/16 11.0	7/16 11.0	1/4 6.5	0.13
79 62 125		5 125					burnished	polished	multi-component grips	1/64 - 1/16 0.1 - 1.7	1/32 0.8	-	-	7/16 11.0	7/16 11.0	1/4 6.5	0.13

Precision Electronics Diagonal Cutters

ESD

DIN ISO 9654

79

Electrically discharging handles – dissipative

- > precision pliers for ultra fine cutting work in electronics and fine mechanics
- > very precisely ground and sharp cutting edges with very small bevels for precise cutting work on small electronic components
- > cutting edge hardness (approx. 64 HRC)
- > approx. 20% lighter than conventional electronics pliers
- > bolted joint with particularly carefully manufactured joint surfaces for even, low-friction movement throughout the entire opening range
- > double spring for a gentle and even opening
- > ergonomically optimized handle covers
- > ball bearing chrome steel; forged, multi stage oil-hardened

79 02 120 ESD

Mini-head

79 02 125 ESD

Round head

79 12 125 ESD

Specifically for cutting through hard wire and piano wire

79 22 120 ESD

Mini-head

79 22 125 ESD

Round head

79 32 125 ESD

Pointed head

79 42 125 ESD

Pointed head

79 52 125 ESD

Pointed head; with lead catcher – no uncontrolled loss of cut wire ends

79 62 125 ESD

Pointed head; with lead catcher – no uncontrolled loss of cut wire ends

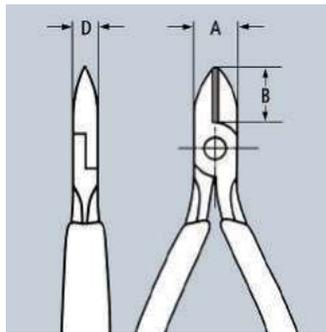

79 02 120 ESD



79 02 125 ESD



79 22 120 ESD



79 22 125 ESD



79 32 125 ESD



79 42 125 ESD



Sets of pliers can be found on page 203



ESD Pliers (electrostatic discharge)

Electrostatic energy is discharged through the handles in a gradual and controlled manner which protects components endangered by electrostatic discharge in accordance with applicable standards, e.g. IEC TR 61 340-5, DIN EN 61 340-5, SP Method 2472



Product Number	Packaging	↔ Inch mm		Pliers	Head	Handles	Cutting capacities				Dimensions			⚖ lbs
							⊘ Inch ⊘ mm	⊘ Inch ⊘ mm	⊘ Inch ⊘ mm	⊘ Inch ⊘ mm	A Inch mm	B Inch mm	D Inch mm	
79 02 120 ESD		4 3/4 120		burnished	polished	ESD multi-component grips	1/64 - 1/16 0.2 - 1.4	3/64 1.0	1/32 0.6	-	23/64 9.0	1/4 6.5	1/4 6.5	0.13
79 02 125 ESD		5 125		burnished	polished	ESD multi-component grips	1/64 - 5/64 0.2 - 2.0	3/64 1.3	1/32 0.7	-	7/16 11.0	25/64 10.0	1/4 6.5	0.13
79 12 125 ESD		5 125		burnished	polished	ESD multi-component grips	1/64 - 5/64 0.3 - 2.0	3/64 1.3	3/64 1.0	1/64 0.2	7/16 11.0	25/64 10.0	1/4 6.5	0.13
79 22 120 ESD		4 3/4 120		burnished	polished	ESD multi-component grips	1/64 - 3/64 0.1 - 1.3	1/32 0.8	-	-	23/64 9.0	1/4 6.5	1/4 6.5	0.13
79 22 125 ESD		5 125		burnished	polished	ESD multi-component grips	1/64 - 5/64 0.1 - 2.0	3/64 1.0	-	-	7/16 11.0	25/64 10.0	1/4 6.5	0.13
79 32 125 ESD		5 125		burnished	polished	ESD multi-component grips	1/64 - 1/16 0.2 - 1.5	3/64 1.1	1/64 0.2	-	7/16 11.0	7/16 11.0	1/4 6.5	0.13
79 42 125 ESD		5 125		burnished	polished	ESD multi-component grips	1/64 - 1/16 0.1 - 1.5	1/32 0.8	-	-	7/16 11.0	7/16 11.0	1/4 6.5	0.13
79 42 125 Z ESD		5 125		burnished	polished	ESD multi-component grips	up to 1/64 up to 0.2	-	-	-	7/16 11.0	7/16 11.0	1/4 6.5	0.13
79 52 125 ESD		5 125		burnished	polished	ESD multi-component grips	1/64 - 1/16 0.2 - 1.7	1/32 0.9	1/64 0.5	-	7/16 11.0	7/16 11.0	1/4 6.5	0.13
79 62 125 ESD		5 125		burnished	polished	ESD multi-component grips	1/64 - 1/16 0.1 - 1.7	1/32 0.8	-	-	7/16 11.0	7/16 11.0	1/4 6.5	0.13

Pipe and Connector Pliers

for traps, tube fittings and connectors

81

For pipes, and connectors up to 3 5/32" (80 mm) diameter
 Fine push-button adjustment for the perfect fit on different sized workpieces

- > ideal for tightening and loosening screw connections, plastic pipe fittings and round nuts
- > soft jaw version is an ideal tool for cannon plugs in aviation and electrical connections in high performance automotive, truck and trailer applications
- > for gentle loosening of hoses on nozzles
- > 25 adjustment positions
- > robust, heavy-duty box-joint design
- > ergonomic handle geometry
- > chrome vanadium electric steel; forged, oil-hardened

81 01 250

With serrated gripping jaws; up to 3 5/32" (80 mm) dia.

81 11 250

With exchangeable plastic jaws for sensitive surfaces; up to 3" (75 mm) dia.



81 01 250



81 11 250

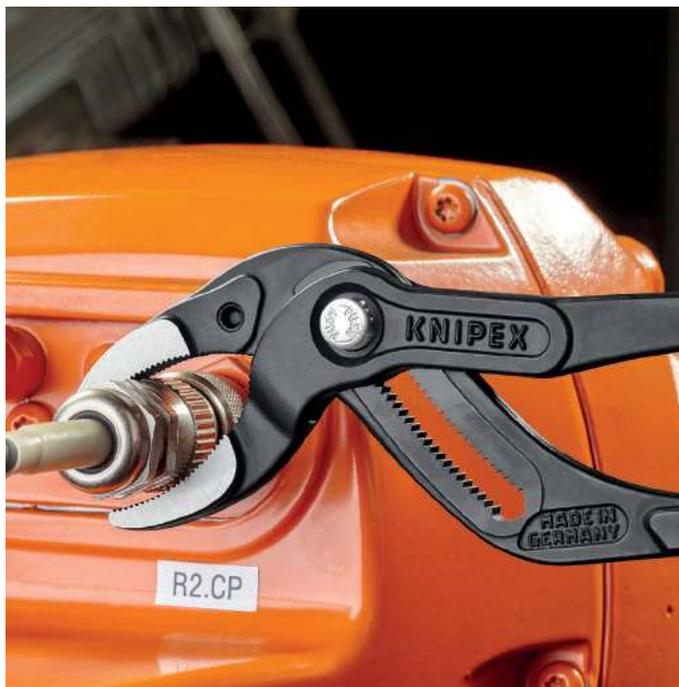

Product Number	Packaging	↔ Inch mm		Pliers	Handles	Capacity Ø Inch Ø mm	Adjustment positions	⚖️ lbs
81 01 250	X	10 250		black atramentized	non-slip plastic coated	1 - 3 5/32 25 - 80	25	0.76
81 11 250	X	10 250		black atramentized	non-slip plastic coated	3/8 - 3 10 - 75	25	0.76
81 19 250	1 pair of plastic jaws for 81 11 250							

Pipe Wrenches 90°

DIN 5234

83
1

- > Swedish pattern
- > 90° angled jaws
- > jaws with offset teeth in opposite directions for a strong grip
- > induction hardened teeth for long life
- > i-beam handle design
- > captive adjusting nut
- > red powder-coated, jaws bright ground
- > chrome vanadium electric steel; forged, multi stage oil-hardened



83 10 015

∠90°

Product Number	Packaging	↔ Inch mm		Pliers	 ∅ Inch ∅ mm	 Inch	 lbs
83 10 010		12 1/4 310	∠90°	red powder-coated	1 21/32 42	1	1.74
83 10 015		16 1/2 420			2 3/64 60	1 1/2	3.08
83 10 020		22 560			2 3/4 70	2	5.37
83 10 030		25 1/2 650			4 3/8 110	3	7.44
83 10 040		29 1/2 750			5 1/8 130	4	10.56

Pipe Wrenches 45°

DIN 5234

83
2

- > Swedish pattern
- > 45° angled jaws
- > jaws with offset teeth in opposite directions for a strong grip
- > induction hardened teeth for long life
- > i-beam handle design
- > captive adjusting nut
- > red powder-coated, jaws bright ground
- > chrome vanadium electric steel; forged, multi stage oil-hardened



83 20 015

∠45°

Product Number	Packaging	↔ Inch mm		Pliers	 ∅ Inch ∅ mm	 Inch	 lbs
83 20 010		12 1/2 320	∠45°	red powder-coated	1 21/32 42	1	1.74
83 20 015		17 430			2 3/64 60	1 1/2	3.13
83 20 020		22 1/2 570			2 3/4 70	2	5.5

Pipe Wrenches S-Type

DIN 5234

83
3

- > slim, s-type jaw
- > jaws with offset teeth in opposite directions for a strong grip
- > induction hardened teeth for long life
- > three-point gripping on pipes, self-locking
- > i-beam handle design
- > captive adjusting nut
- > red powder-coated, jaws bright ground
- > chrome vanadium electric steel; forged, multi stage oil-hardened



83 30 015



Product Number	Packaging	↔ Inch mm		Pliers	⊘ Ø Inch Ø mm	⊘ Inch	⚖ lbs
83 30 005		9 1/2 245		red powder-coated	1 3/8 35	1/2	1.04
83 30 010		12 1/2 320			1 21/32 42	1	1.86
83 30 015		16 1/2 420			2 3/64 60	1 1/2	3.31
83 30 020		21 1/4 540			2 3/4 70	2	5.68
83 30 030		26 3/4 680			4 3/4 120	3	9.33

Pipe Wrenches S-Type

with rapid adjustment

83
6

- > time-saving, precise adjustment of the opening width at the press of a button directly on the workpiece
- > less effort required due to self-locking action
- > no unintentional shifting of the pliers
- > pinch guard prevents operators' fingers being pinched
- > maximum load capacity due to completely hardened handles
- > high-wear resistance due to the induction hardened teeth
- > chrome vanadium electric steel; forged, multi stage oil-hardened



83 60 010



83 61 010



Product Number	Packaging	↔ Inch mm		Pliers	Handles	⊘ Ø Inch Ø mm	⊘ Inch	⚖ lbs
83 60 010		13 330		red powder-coated		1 21/32 42	1	1.96
83 60 015		16 1/2 420				2 3/64 60	1 1/2	3.30
83 61 010		13 330		grey powder-coated	plastic coated	1 21/32 42	1	2.11
83 61 015		16 1/2 420				2 3/64 60	1 1/2	3.24
83 61 020		22 560				2 3/4 70	2	5.47

Cycle Pliers

DIN ISO 5743

84

- > for very narrow screw connections
- > special tool steel; forged, oil-hardened

84 11 200
Straight head

84 21 200
20° angled head



84 11 200



84 21 200
 $\angle 20^\circ$

Product Number	Packaging	\leftrightarrow Inch mm		Pliers	Head	Handles	Recess Ø Inch Ø mm	Head thickness Inch mm	 lbs
84 11 200		8 200		black atramentized	polished	plastic coated	15/64 / 25/64 6 / 10	9/64 3.5	0.39
84 21 200		8 200	$\angle 20^\circ$	black atramentized	polished	plastic coated	15/64 / 25/64 6 / 10	9/64 3.5	0.40

KNIPEX SmartGrip®

Water Pump Pliers with automatic adjustment
DIN ISO 8976

85

- > ideal for frequent changeovers to workpieces of different sizes
- > automatic adjustment for one-hand operation both for right-handed and left-handed use
- > good access to the workpiece due to the slim dimensions in the head and joint area and flush joint bolt
- > self-locking on pipes and nuts: no slipping off the workpiece and low handforce required
- > gripping surfaces with special hardened teeth, teeth hardness (approx. 61 HRC): low wear and reliable gripping
- > box-joint design: high stability because of double guide
- > pinch guard prevents operators' fingers being pinched
- > locking lever for space saving transport with reliable closed handles
- > chrome vanadium electric steel; forged, multi stage oil-hardened



85 01 250 US

Adjustment to the workpiece is automatic with the KNIPEX SmartGrip®! Just grip the pliers handles and squeeze – it's that easy!



Product Number	Packaging	\leftrightarrow Inch mm	Pliers	Head	Handles	 Ø Inch Ø mm	 Inch mm	 lbs
85 01 250 US		10 250	grey atramentized	polished	non-slip plastic coated	1 1/4 32	1 13/32 36	0.82

Removing spring hose clamps has never been easier. These Hose Clamp Pliers have rotatable tips, making them maneuverable from different angles and easier to use in confined areas.

7 1/4" version is perfect for smaller engines up to 2"

10" version can be used on a variety of clamps up to 2 3/4"

- > rotatable tips for securely gripping the clamps in all positions
- > jaw inserts can also be rotated under load
- > extremely good leverage which allows clamps to be opened and moved easily without great effort
- > slim head design, narrow head width, and rotatable grip inserts make this an ideal tool especially in confined areas
- > detach hoses gently using the serrated jaw behind the tips
- > chrome vanadium electric steel; forged, oil-hardened



85 51 180 A



85 51 250 A



A single pair of pliers for various sizes of clamps up to 2 3/4" diameter. Rotating jaw inserts enable them to adapt to any position while still guaranteeing that clamps are securely positioned in the pliers.

APPLICATION AREAS CARS/TRUCKS

Air suction, cooling, charge air, water return, thermostat, fuel, heating



Product Number	Packaging	↔ Inch mm		Pliers	Handles	Gripping capacity Ø Inch	Adjustment positions	⚖️ lbs
85 51 180 A	X	7 1/4 180		grey atramentized	non-slip plastic coated	2	15	0.39
85 51 250 A	X	10 250				2 3/4	25	0.75
85 59 250 A	Spare part grip insert assortment for 85 51 180 A / 85 51 250 A / 85 51 250 AF							

Spring Hose Clamp Pliers

with locking device

85
51

The locking device keeps the clamp open and stays locked in position without the need to grip and hold onto the pliers until the user is ready to move the clamp.

One-hand release

- > rotatable tips for securely gripping the clamps in all positions
- > jaw inserts can also be rotated under load
- > extremely good leverage which allows clamps to be opened and moved easily without great effort
- > slim head design, narrow head width, and rotatable grip inserts make this an ideal tool especially in confined areas
- > detach hoses gently using the serrated jaw behind the tips
- > chrome vanadium electric steel; forged, oil-hardened



85 51 250 AF

Product Number	Packaging	↔ Inch mm		Pliers	Handles	Gripping capacity Ø Inch	Adjustment positions	⚖ lbs
85 51 250 AF	X	10 250		grey atramentized	non-slip plastic coated	2 3/4	19	0.77
85 59 250 A	Spare part grip insert assortment for 85 51 250 A / 85 51 250 AF							

Hose Clamp Pliers

for Click Clamps

85
51

Opening and closing Click Clamps does not require a special skill; it requires a special tool. No need to replace the OEM clamp with a screw clamp, these pliers will not harm the clamps they're compressing, allowing them to be reused over and over again.

- > rotating tips for reliably gripping of clamps in any position
- > high leverage allows clamps to be opened and closed again comfortably and easily without a great deal of effort
- > for easy working on fuel hoses, vacuum pipes with suction nozzles and many other applications
- > detach hoses gently using the serrated jaw behind the tips
- > slim head design, narrow head width, and rotatable grip inserts make this an ideal tool especially in confined areas
- > chrome vanadium electric steel; forged, oil-hardened



85 51 180 C



85 51 250 C



Hose clamp without limit stop



Hose clamp with limit stop



Serrated gripping jaws for easy loosening of tight hoses



Rotating tips

Product Number	Packaging	↔ Inch mm		Pliers	Handles	Diameter Ø inch Ø mm	Adjustment positions	⚖ lbs
85 51 180 C	X	7 1/4 180		grey atramentized	non-slip plastic coated	1 3/4 45	12	0.38
85 51 250 C	X	10 250				2 3/4 70	15	0.75
85 59 250 C	Spare part grip insert assortment for 85 51 180 C / 85 51 250 C							

Pliers Wrenches

Pliers and a wrench in a single tool

DIN ISO 5743

86

Replaces a full set of inch and metric open end wrenches

Smooth jaws for damage free installation of plated fittings – working directly on chrome!

- > adjustable tightening tool
- > excellent for gripping, holding, pressing and bending applications
- > zero backlash jaw surface pressure prevents damage to edges of sensitive components
- > adjustment at the touch of a button directly on the workpiece
- > parallel jaws allow infinitely variable gripping of all widths to the specified maximum size
- > reliable catching of the hinge bolt: no unintentional shifting
- > the action of the jaws allows bolted connections to be tightened and released quickly using the ratchet principle
- > lever transmission greater than 10 - 1 for strong gripping power
- > chrome vanadium electric steel; forged, oil-hardened

Length 5"

Mini pliers wrench for precision mechanics; particularly suitable for working on small bolted connections; very good access in very confined spaces

Length 6"

Ideal multipurpose wrench in pocket size; indispensable companion in emergency tool kit

Length 7 1/4"

With narrow gripping jaws – for fastening/loosening situations requiring a slim tool

Length 10"

NOW with 2" capacity, lightweight, thinner head and adjustment scale for presetting the adjustment point

86 05 180 T BKA / 86 05 250 T BKA*

Pliers with integrated tether attachment point for tool drop protection system

86 43 250 US

15° angled pliers handle provides space for counter screw connections or bolted fittings on surfaces

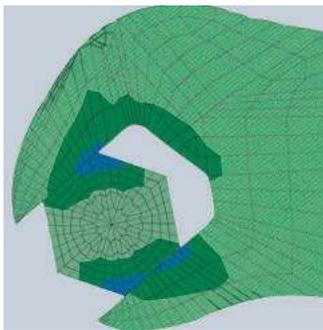

Pliers wrench: zero backlash contact pressure, no damage to edges

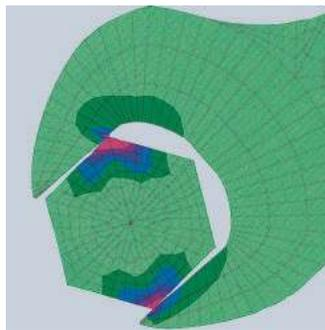

Conventional open end wrench: edge pressure causes surface damage on edges of nuts and bolts



10" Version: opening width lasered onto the pliers head (metric on the front and imperial on the back)

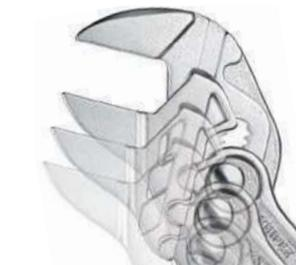

Fast adjustment by pushing a button



86 03 125



86 03 150



86 03 180



86 05 250



86 05 250 T



86 03 300



86 01 250



86 06 250 US



86 43 250 US



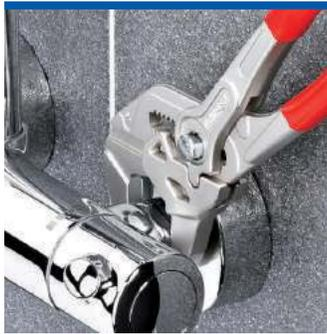

Working on plated fittings without damaging the surface



Replaces a full set of inch and metric open end wrenches



Ideal for bending work



Opening width lasered onto the pliers head (metric on the front and imperial on the back)

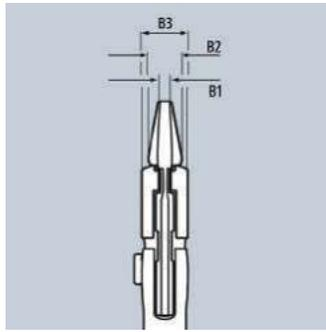

The smooth jaws grip all parallel surfaces in the capacity range with a high degree of pressure if necessary and open up almost unlimited application possibilities for the pliers wrench: e.g. for tightening locknuts, exerting pressure to activate the adhesive power of contact adhesives, edge breaking in tile work, snapping cable ties, utilization as a small vice.

Product Number	Packaging	↔ Inch mm		Pliers	Handles	 Inch mm	Adjustment positions	Dimensions			 lbs
								B1 Inch mm	B2 Inch mm	B3 Inch mm	
86 01 250	X	10 250		black atramentized	non-slip plastic coating	2 52	19	5/16 8.0	5/16 8.0	35/64 14.0	1.00
86 02 250	X	10 250		black atramentized	multi-component grips	2 52	19	5/16 8.0	5/16 8.0	35/64 14.0	1.03
86 03 125	X	5 125		chrome plated	plastic coated	7/8 23	11	1/8 3.0	13/64 5.0	3/8 9.5	0.23
86 03 150	X	6 150				1 27	14	3/16 4.7	9/32 7.0	13/32 10.5	0.39
86 03 180	X	7 1/4 180				1 3/8 35	13	13/64 5.0	5/16 8.0	15/32 12.0	0.56
86 03 250	X	10 250				2 52	19	5/16 8.0	5/16 8.0	35/64 14.0	1.18
86 03 300	X	12 300				2 3/8 60	22	3/8 9.5	3/8 9.5	19/32 15.0	1.61
86 05 150		6 150						multi-component grips	1 27	14	3/16 4.7
86 05 180	X	7 1/4 180			multi-component grips	1 3/8 35	13	13/64 5.0	5/16 8.0	15/32 12.0	0.61
86 05 180 T BKA	X	7 1/4 180		chrome plated	multi-component grips, integrated tether attachment point	1 3/8 35	13	13/64 5.0	5/16 8.0	15/32 12.0	0.66
86 05 250	X	10 250			slim multi-component grips	2 52	19	5/16 8.0	5/16 8.0	35/64 14.0	1.26
86 05 250 T BKA	X	10 250			multi-component grips, integrated tether attachment point	2 52	19	5/16 8.0	5/16 8.0	35/64 14.0	1.35
86 06 250 US	X	10 250	 ⚠ 1000V	chrome plated	insulated with multi-component grips, VDE-tested	2 52	19	5/16 8.0	5/16 8.0	35/64 14.0	1.14
86 43 250 US	X	10 250	 ∠15°	chrome plated	plastic coated	1 3/4 46	19	5/16 8.0	5/16 8.0	35/64 14.0	1.19

*Learn more about our tethered tool system on pages 207-211

Pliers Wrench XL

Pliers and a wrench in a single tool
DIN ISO 5743

86
03

The unique installation tool now in 16" (400 mm) length
For opening widths up to 3 3/8" (85 mm)

- > excellent for gripping, holding, pressing and bending applications
- > optimized adjustment to the workpiece with hand-friendly position of grips
- > reliable catching of the hinge bolt: no unintentional shifting
- > lever transmission greater than 10 – 1 for strong gripping power
- > adjustable tightening tool
- > replaces diverse, expensive, large open end wrenches up to 3 3/8"
- > parallel jaws allow infinitely variable gripping of all widths to the specified maximum size
- > smooth jaws, for gentle installation of quality union joints made from brass, red brass or stainless steel
- > zero backlash jaw surface pressure prevents damage to edges of sensitive components
- > the action of the jaws allows bolted connections to be tightened and released quickly using the ratchet principle
- > adjustment at the touch of a button directly on the workpiece
- > chrome vanadium electric steel; forged, oil-hardened



86 03 400 US

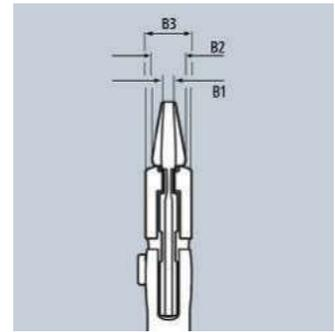

Open end wrenches with fixed opening widths are expensive, especially when used for large union joints. The KNIPEX Pliers Wrench XL, with its adjustable jaw opening up to AF 3 3/8" (85 mm), offers enormous savings potential.

Product Number	Packaging	↔ Inch mm	Pliers	Handles	 Inch mm	Adjustment positions	Dimensions			 lbs
							B1 Inch mm	B2 Inch mm	B3 Inch mm	
86 03 400 US		16 400	chrome plated	plastic coated	3 3/8 85	25	31/64 12.5	5/8 16	25/32 20	3.22

adjustable tightening tool – replaces diverse, expensive, large open end wrenches

parallel jaws give a more solid grip; its design allows flexible adjustment up to a maximum size of 3 3/8"

smooth jaws, for damage free installation of quality union joints made from brass, red brass, stainless steel or chrome plated material

zero backlash jaw pressure prevents damage to edges of sensitive components

the ratchet type principle allows quick and easy tightening and release of bolted connections

push-button for adjustment on the workpiece





Cobra®

- > adjustment at the touch of a button directly on the workpiece
- > fine adjustment for optimum adaptation to different size workpieces and a comfortable gripping position
- > self-locking on pipes and nuts: no slipping off the workpiece and low handforce required
- > gripping surfaces with special hardened teeth, teeth hardness (approx. 61 HRC): low wear and reliable gripping
- > box-joint design: high stability because of double guide
- > reliable catching of the hinge bolt: no unintentional shifting
- > pinch guard prevents operators' fingers being pinched
- > chrome vanadium electric steel; forged, multi stage oil-hardened

87 02 250 / 87 02 250 T BKA

With slim, two-color multi-component sleeves for better handling and easier transport

87 02 180 T BKA / 87 02 250 T BKA / 87 02 300 T BKA*

Pliers with integrated tether attachment point for tool drop protection system



87 01 125
 



87 01 150
 



87 01 180
 



87 01 250
 



87 01 300
 



87 02 250
 



87 02 250 T BKA
 



Fine adjustment by pushing a button: fast and comfortable



Fast and firm adjustment directly on the workpiece



Square



Hex



Round



Flat

KNIPEX Cobra® – the High-Tech Water Pump Pliers

No more time-consuming test-adjusting of the correct opening size. Just position the upper jaw to the workpiece, push button and slide close the lower jaw, ingeniously simple.

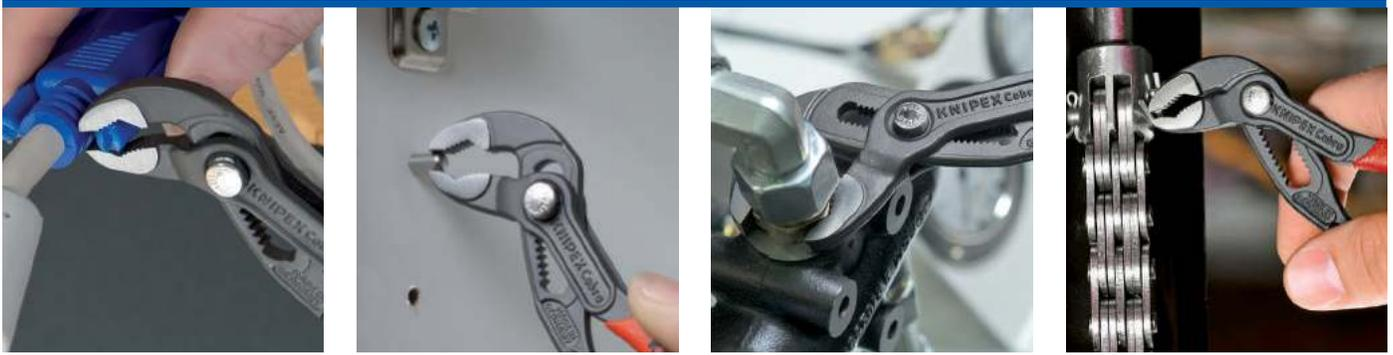

Teeth set against the direction of rotation have a self-clamping effect and prevent slipping off the workpiece

The Original Push-Button Pliers

Product Number	Packaging	↔ Inch mm		Pliers	Head	Handles	 Ø Inch Ø mm	 Inch mm	Adjustment positions	 lbs
87 01 125	X	5 125		grey atramentized	polished	non-slip plastic coated	1 1/16 27	1 1/16 27	13	0.19
87 01 150	X	6 150					1 1/4 32	1 3/16 30	11	0.32
87 01 180	X	7 1/4 180		grey atramentized	polished	non-slip plastic coated	1 1/2 42	1 27/64 36	18	0.40
87 01 250	X	10 250					2 50	1 3/4 46	25	0.74
87 01 300	X	12 300		grey atramentized	polished	non-slip plastic coated	2 3/4 70	2 3/64 60	30	1.22
87 02 180	X	7 1/4 180		grey atramentized	polished	multi-component grips	1 1/2 42	1 27/64 36	18	0.43
87 02 180 T BKA	X	7 1/4 180		grey atramentized	polished	multi-component grips, integrated tether attachment point	1 1/2 42	1 27/64 36	18	0.48
87 02 250	X	10 250		grey atramentized	polished	slim multi-component grips	2 50	1 3/4 46	25	0.81
87 02 250 T BKA	X	10 250		grey atramentized	polished	slim multi-component grips, integrated tether attachment point	2 50	1 3/4 46	25	0.81
87 02 300	X	12 300		grey atramentized	polished	multi-component grips	2 3/4 70	2 3/64 60	30	1.33
87 02 300 T BKA	X	12 300		grey atramentized	polished	multi-component grips, integrated tether attachment point	2 3/4 70	2 3/64 60	30	1.40

*Learn more about our tethered tool system on pages 207-211

KNIPEX Cobra® XL/XXL

Pipe Wrenches and High-Tech Water Pump Pliers

DIN ISO 5743

87
0

- > greater gripping capacity and lighter weight than comparable pipe gripping wrenches
- > fast push-button adjustment directly on the workpiece, no unintentional slipping of the joint
- > fine adjustment for optimum adaptation to different size workpieces and a comfortable gripping position
- > self-locking on pipes and nuts: no slipping off the workpiece and low handforce required
- > gripping surfaces with special hardened teeth, teeth hardness (approx. 61 HRC): low wear and reliable gripping
- > box-joint design: high stability because of double guide
- > pinch guard prevents operators' fingers being pinched
- > chrome vanadium electric steel; forged, multi stage oil-hardened

Cobra®

The KNIPEX Cobra® XL and XXL offer the power and comfort of water pump pliers while being lighter in weight and having a greater gripping capacity than comparable pipe wrenches. The Cobra® XL can grip a 3 1/2" pipe coupling and weighs 50% less than 2" pipe wrenches, which have a much lower gripping capacity. With its compact length of 16" (400 mm), the Cobra XL is perfect for the plumber's toolbox.

The Cobra® XXL with its capacity of up to 4 1/2" only weighs as much as a 2" pipe wrench. It's 22" size makes it the biggest pliers around!



Fine adjustment by pushing a button: fast and comfortable



Fast and firm adjustment directly on the workpiece



87 01 400 US



87 01 560 US



Product Number	Packaging	↔ Inch mm		Pliers	Head	Handles	○ Ø Inch Ø mm	⬡ Inch mm	Adjustment positions	⚖ lbs
87 01 400 US	X	16 400		grey atramentized	polished	plastic coated	3 1/2 90	3 3/4 95	27	2.62
87 01 560 US	X	22 560		grey atramentized	polished	plastic coated	4 1/2 115	4 3/4 120	20	6.06

KNIPEX Cobra®...matic

High-Tech Water Pump Pliers
DIN ISO 8976

87
1

All features of the KNIPEX Cobra® 87 01 250 along with these special features:

- > automatic adjustment at the touch of a button directly on the workpiece
- > the securely positioned spring ensures that the pliers close automatically once the push-button is activated (one-hand operation!)
- > chrome vanadium electric steel; forged, multi stage oil-hardened



87 11 250



Product Number	Packaging	↔ Inch mm		Pliers	Head	Handles	⊘ Ø Inch Ø mm	⬡ Inch mm	Adjustment positions	⚖ lbs
87 11 250	X	10 250		grey atramentized	polished	non-slip plastic coated	2 50	1 13/16 46	25	0.75
87 19 250	Spare spring for 87 11 250									

KNIPEX Cobra® QuickSet

High-Tech Water Pump Pliers
DIN ISO 8976

87
2

Fully open, push, grab!

Fast adjustment on the workpiece by sliding the pliers handle

- > combines the proven, reliable locking of the hinge bolt with an additional push function which makes it easier to work in very confined and inaccessible areas
- > adjustment directly on the workpiece by sliding the pliers handle
- > reliable locking of the hinge bolt with the first workload. The gripping width of the pliers is then fixed and can only be adjusted by pressing the button
- > the pliers stay locked in place and can only be readjusted by pressing the button and resetting
- > chrome vanadium electric steel; forged, multi stage oil-hardened



87 21 250



87 21 300



87 22 250



Press the button – open pliers completely



Position top jaw and simply slide and close pliers



The push-button stays locked in place once the handles are squeezed

Proven Cobra® functions

- > self-locking on pipes and nuts: no slipping off the workpiece and low handforce required
- > fine adjustment for optimum adaptation to different size workpieces and a comfortable handle width

Product Number	Packaging	↔ Inch mm		Pliers	Head	Handles	⊘ Ø Inch Ø mm	⬡ Inch mm	Adjustment positions	⚖ lbs
87 21 250	X	10 250		grey atramentized	polished	non-slip plastic coated	2 50	1 3/4 46	25	0.74
87 21 300	X	12 300					2 3/4 70	2 3/64 60		
87 22 250	X	10 250		grey atramentized	polished	slim multi-component grips	2 50	1 3/4 46	25	0.81

KNIPEX Cobra® Insulated

High-Tech Water Pump Pliers, Insulated
DIN ISO 8976 IEC 60900 DIN EN 60900

87
26

- > adjustment by shifting the jaw directly on to the workpiece: fast, secure and comfortable handling
- > opening at the touch of a button apart from the workpiece
- > fine adjustment for optimum adaptation to different workpiece sizes and comfortable gripping position
- > good access to the workpiece due to slim size in the head and joint area
- > self-locking on pipes and nuts: no slipping off the workpiece and low handforce required
- > gripping surfaces with special hardened teeth, teeth hardness (approx. 61 HRC): low wear and reliable gripping
- > box-joint design: high stability because of double guide
- > pinch guard prevents operators' fingers being pinched
- > chrome vanadium electric steel; forged, multi stage oil-hardened

The adjustment action to adapt to the workpiece is easy and reliable with the KNIPEX Cobra® Insulated: place the upper gripping jaw of the opened pliers on the workpiece, push pliers to close, done!



87 28 250 US

⚡ 1000 V ASTM 



Quick adjustment to the workpiece without using a push-button



Just push the pliers handle to adjust

Product Number	Packaging	↔ Inch mm		Pliers	Head	Handles	⊘ Inch ⊘ mm	⊘ Inch mm	Adjustment positions	⚖ lbs
87 28 250 US	X	10 250	⚡ 1000 V ASTM 	grey atramentized	polished	insulated multi-component grips, ASTM-tested	2 50	1 3/4 46	24	0.88

KNIPEX Raptor™ Pliers

DIN ISO 5743

87
4

- > for inch and metric nuts and screws with widths across flats from 3/8" - 1 1/4" (10 - 32 mm); self-locking in the range from 11/16" (17 mm): no slipping off the workpiece
- > reliable and tight gripping of rounded, rusty or overly painted nuts and screws
- > ideal for work on vehicle brake systems
- > quick tightening of nuts and bolts using ratchet action
- > adjustment at the touch of a button directly on the workpiece, one-hand operation
- > fine adjustment for optimum adaptation to different size workpieces and a comfortable gripping position
- > box-joint design: high stability because of double guide
- > reliable catching of the hinge bolt: no unintentional shifting
- > favorable lever action: optimum transmission of force
- > pinch guard prevents operators' fingers being pinched
- > replaces a set of wrenches, ideal for tightening locknuts
- > chrome vanadium electric steel; forged, multi stage oil-hardened



87 41 250



The Raptor Pliers combines the convenience of the comfortable push-button adjustment on the workpiece and the function of an all-purpose tightening tool. Jaw gripping with zero backlash prevents slipping on the bolt head or rounding edges.

Even rusty or thick coated bolted connections which have no surfaces capable of being gripped reliably by a conventional wrench can be managed by the exceptionally powerful closing gripping jaws of this wrench.

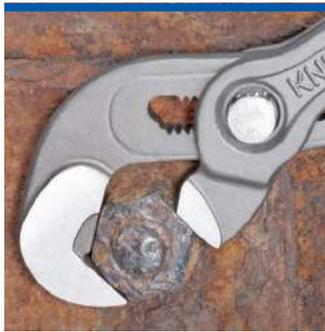

Grips rusted nuts with rounded edges



Self-locking: no slipping off workpieces; less effort required



Raptor™ Pliers as the second spanner for tightening locknuts



Fine adjustment by pushing a button: fast and comfortable

Product Number	Packaging	↔ Inch mm		Pliers	Head	Handles	⬡ Inch mm	Adjustment positions	⚖ lbs
87 41 250	X	10 250		grey atramentized	polished	non-slip plastic coated	3/8 - 1 1/4 10 - 32	15	0.72

KNIPEX Cobra® ES

High-Tech Water Pump Pliers, extra-slim
DIN ISO 8976

87
5

- > ideal for service and maintenance, equipment repair, automotive and general industry
- > long, narrow jaws
- > good access to the workpiece due to very slim construction of head and joint area
- > grips flat material due to three-point rest
- > adjustment at the touch of a button directly on the workpiece
- > fine adjustment for optimum adaptation to different size workpieces and a comfortable gripping position
- > self-locking on pipes and nuts: no slipping off the workpiece and low handforce required
- > box-joint design: high stability because of double guide
- > reliable catching of the hinge bolt: no unintentional shifting
- > favorable lever action: optimum transmission of force
- > pinch guard prevents operators' fingers being pinched
- > chrome vanadium electric steel; forged, multi stage oil-hardened



Fine adjustment by pushing a button: fast and comfortable



Slim head and joint area (compared to conventional water pump pliers)



Optimum access to the workpiece. Ideal for service and maintenance, equipment repair, automotive and general industry



Grips nuts up to 1 3/8" (34 mm) across flats



87 51 250

Product Number	Packaging	↔ Inch mm		Pliers	Head	Handles	⊘ Inch mm	⬡ Inch mm	Max. parallel opening width Inch mm	Max. gripping depth Inch mm	Adjustment positions	⚖ lbs
87 51 250	X	10 250		grey atramentized	polished	non-slip plastic coated	1 1/4 32	1 3/8 34	1 1/2 37	1 5/8 42	19	0.72

KNIPEX Alligator®

Water Pump Pliers

DIN ISO 8976

88

More output and comfort compared to conventional water pump pliers of the same length: offers 9 adjustment positions for 30% more gripping capacity

- > good access to the workpiece due to slim size in the head and joint area
- > self-locking on pipes and nuts: no slipping off the workpiece and low handforce required
- > gripping surfaces with special hardened teeth, teeth hardness (approx. 61 HRC): low wear and reliable gripping
- > box-joint design: high stability because of double guide
- > robust construction; particularly suitable for outdoor work
- > pinch guard prevents operators' fingers being pinched
- > chrome vanadium electric steel; forged, multi stage oil-hardened

88 02 250 / 88 02 250 T BKA

Slim, two-color multi-component sleeves for better handling and easier transport

88 02 250 T BKA / 88 02 300 T BKA*

Pliers with integrated tether attachment point for tool drop protection system



Self-clamping on pipes and nuts: no slipping off the workpiece. Less handforce is required since handles do not need to be squeezed. Simply put pressure on the upper handle for a powerful grip.



88 01 180
 



88 01 250
 



88 02 250
 



88 02 250 T BKA
 



88 07 300
   



88 08 250 US
  

Alligator®



Product Number	Packaging	↕ Inch mm		Pliers	Head	Handles	∅ Inch ∅ mm	∅ Inch mm	Adjustment positions	⚖ lbs
88 01 180	X	7 1/4 180					1 1/2 42	1 27/64 36	9	0.40
88 01 250	X	10 250		black atramentized	polished	non-slip plastic coated	2 50	1 13/16 46	9	0.75
88 01 300	X	12 300					2 3/4 70	2 3/64 60	9	1.19
88 02 180	X	7 1/4 180		black atramentized	polished	multi-component grips	1 1/2 42	1 27/64 36	9	0.47
88 02 250	X	10 250		black atramentized	polished	slim multi-component grips	2 50	1 13/16 46	9	0.83
88 02 250 T BKA	X	10 250		black atramentized	polished	slim multi-component grips, integrated tether attachment point	2 50	1 13/16 46	9	0.88
88 02 300	X	12 300		black atramentized	polished	multi-component grips	2 3/4 70	2 3/64 60	9	1.30
88 02 300 T BKA	X	12 300		black atramentized	polished	multi-component grips, integrated tether attachment point	2 3/4 70	2 3/64 60	9	1.39
88 07 300		12 300		chrome plated	polished	plastic dipped insulated, VDE-tested	2 3/4 70	2 3/64 60	9	1.46
88 08 250 US	X	10 250		black atramentized	polished	insulated, multi-component handles, ASTM-tested	1 31/32 50	1 13/16 46	9	0.87

*Learn more about our tethered tool system on pages 207-211

KNIPEX Alligator® XL

Pipe Wrench and Water Pump Pliers

DIN ISO 5743

88

The classic model in 16" (400 mm) length

Robust construction; particularly suitable for outdoor work

- > good access to the workpiece due to slim size in the head and joint area
- > pinch guard prevents operators' fingers being pinched
- > gripping surfaces with special hardened teeth, teeth hardness (approx. 61 HRC): low wear and reliable gripping
- > self-locking on pipes and nuts: no slipping off the workpiece and low handforce required
- > box-joint design: high stability because of double guide
- > robust adjustment mechanism, dirt resistant, easy to clean; particularly suitable for outdoor work
- > 11-notch adjustment positioning with optimized adjustment to the workpiece and user-friendly handle position
- > gripping capacity up to 3 1/2"
- > chrome vanadium electric steel; forged, multi stage oil-hardened

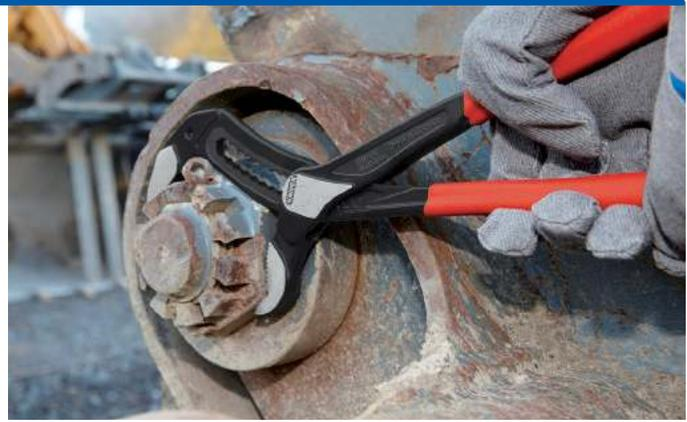

88 01 400



The KNIPEX Alligator® XL offers the performance and comfort of a water pump pliers while being 50% lighter in weight and having a greater gripping capacity (3 1/2") than comparable pipe wrenches.

With their handy length of 16" there is a place for KNIPEX Alligator® XL in every tool box.

Robust pliers for very hard applications

gripping surfaces with special hardened teeth, teeth hardness (approx. 61 HRC): low wear and stable gripping

self-locking on pipes and nuts: no slipping off the workpiece and low handforce required

box-joint design: high stability because of the double guide

robust adjustment mechanism, dirt resistant, easy to clean; particularly suitable for outdoor work

11-notch adjustment for optimized adjustment to the workpiece and a comfortable handle position



Product Number	Packaging	↔ Inch mm		Pliers	Head	Handles	∅ Inch ∅ mm	∅ Inch ∅ mm	Adjustment positions	⚖ lbs
88 01 400	X	16 400		black atramentized	polished	non-slip plastic coated	3 1/2 90	3 3/4 95	11	2.62



KNIPEX

MADE IN GERMANY

KNIPEX ALLIGATOR

selbst

Water Pump Pliers

Slip joint
DIN ISO 8976

89

- > easy, convenient engagement in 5 different positions
- > tongue and groove slip joint, self-locking on pipes and nuts
- > pinch guard prevents operators' fingers being pinched
- > gripping surfaces with special hardened teeth, teeth hardness (approx. 62 HRC): low wear for secure grip
- > chrome vanadium electric steel; forged, multi stage oil-hardened



89 01 250



Product Number	Packaging	↔ Inch mm		Pliers	Head	Handles	∅ Inch ∅ mm	Inch mm	⚖ lbs
89 01 250		10 250		black atramentized	polished	non-slip plastic coated	1 5/16 34	1 27/64 36	0.75

Mini Water Pump Pliers

Slip joint
DIN ISO 8976

90

- > easy, convenient engagement in 4 different positions
- > tongue and groove slip joint
- > all strain removed from the joint screw, hence no wear on the pivot
- > chrome vanadium electric steel; forged, oil-hardened



90 01 125



Product Number	Packaging	↔ Inch mm		Pliers	Head	Handles	∅ Inch ∅ mm	Inch mm	⚖ lbs
90 01 125		5 125		black atramentized	polished	non-slip plastic coated	11/16 17	35/64 14	0.23

Pipe Cutter

for flexible pipes and flexible hoses

90

20

- > for cutting thin walled pipes (conduit plastic pipes) and flexible hoses with fabric reinforcement of plastic and rubber up to 1" (25 mm) exterior dia. (not suitable for cutting cables)
- > with opening spring and locking lever
- > tool body: plastic, fiberglass-reinforced
- > blades: special tool steel, oil-hardened, interchangeable



90 20 185

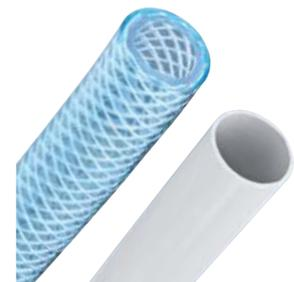

With replaceable blade

Product Number	Packaging	↔ Inch mm		Handles	Cutting capacities ∅ Inch ∅ mm	⚖ lbs
90 20 185		7 1/4 185		tough fiberglass reinforced plastic	1 25	0.40
90 29 185	Spare blade for 90 20 185					

Pipe Cutter

for composite pipes and protective tubes

90
25



Composite pipes of 1/2" – 1" (12–25 mm) dia. are cut cleanly and without deformation



Clean cut of corrugated conduit 3/4" – 1 3/8" (18–35 mm) dia.

- > for cutting composite pipes with a diameter of 1/2" – 1" (12 - 25 mm) and for cutting corrugated conduit pipes with a diameter of 3/4" – 1 3/8" (18 - 35 mm)
- > a calibration arbor can be fitted for Geberit composite pipes with 29/64" and 38/64" (11.5 and 15.0 mm) dia.
- > tool body: high-grade chrome vanadium electric steel, oil-hardened
- > blades: special tool steel, oil-hardened, interchangeable



90 25 20
MM

PATENTED

Product Number	Packaging	↔ Inch mm	Tool	Handles	Cutting capacities composite pipes Ø Inch Ø mm	Cutting capacities protective pipes Ø Inch Ø mm	Blade length Inch mm	⚖ lbs
90 25 20		8 1/4 210	MM	galvanized multi-component grips	1/2 - 1 12 - 25	3/4 - 1 3/8 18 - 35	1 25	0.73
90 29 01	Spare blade for 90 25 20							
90 29 02	1 pair of spare blades for 90 25 20							
90 29 15	Calibration arbor for 90 25 20							

Pipe Cutter

for plastic conduit pipes (electrical installation work)

94
10



- > for clean cutting of plastic pipes (e.g. plastic clad pipes) with a 15/64" – 1 3/8" (6-35 mm) dia.
- > not suitable for cutting cables
- > blade is replaceable and can be retracted in any position
- > low force requirement due to special blade geometry and optimum transmission
- > minimum operator fatigue due to ergonomic handle design and ratchet blade feed in stages
- > housing: die-cast aluminum, red lacquered
- > blade: special tool steel; oil-hardened



94 10 185
MM

Product Number	Packaging	↔ Inch mm	Body	Cutting capacities Ø Inch Ø mm	Cutting edge length Inch mm	⚖ lbs	
94 10 185		7 1/4 185	MM	die-cast aluminum body, red lacquered	15/64 - 1 3/8 6.0 - 35.0	1 3/8 35	1.29
94 19 185	Spare blade for 94 10 185						
94 19 185 02	Torsion spring for 94 10 185						

Pipe Cutter

for composite and plastic pipes

90
25

- > for cutting thick walled plastic and composite pipes from 1 – 1 37/64" (26 - 40 mm) dia.
- > cuts pipes according to the ratchet principle in several strokes
- > self-adapting pipe support positions pipes of various diameters correctly for a rectangular cut
- > tool body: high-grade chrome vanadium electric steel, oil-hardened
- > blades: special tool steel, oil-hardened, interchangeable



Clean cut of thick-walled plastic and composite pipes



Not suitable for thin-walled conduit pipes. Please use article number 90 20 185 for these



90 25 40
 PATENTED

Product Number	Packaging	↔ Inch mm	tool	Handles	Cutting capacities Ø Inch Ø mm	Cutting edge length Inch mm	⚖ lbs
90 25 40		8 1/4 210	 galvanized	multi-component grips	1 - 1 37/64 26 - 40	1 37/64 40	1.10
90 29 40	Spare blade for 90 25 40						

Punch Lock Riveters

90
4

- > to join metal section sheets used in dry walling with a lock seam
- > for U- and C-shaped sections with max 3/64" (5/64 x 1/64) metal (1.2 mm; 2 x 0.6 mm)
- > minimal handforce required due to optimum lever transmission
- > pliers body: special tool steel, rolled, oil-hardened



Setting the pliers for connection of two metal section sheets



The punching tool is pressed through the metal section sheets

90 42 250
For one-hand operation

90 42 250



90 42 340



Product Number	Packaging	↔ Inch mm	Pliers	Handles	Max. Capacity Inch mm	⚖ lbs
90 42 250		10 250	 burnished	multi-component grips	3/64 (5/64 x 1/64) 1.2 (2 x 0.6)	1.49
90 42 340		13 25/64 340	burnished	multi-component grips	3/64 (5/64 x 1/64) 1.2 (2 x 0.6)	1.96
90 49 340	Spare punch for 90 42 340					
90 49 340 M	Spare die for 90 42 340					

Sheet Metal Nibbler

90
55

- > for cutting iron, copper or aluminum plate up to max. 3/64" (1.2 mm) thickness, plastic up to max. 5/64" (2.0 mm) thickness
- > materials are cut without deformation
- > clean cut edges
- > with chip breaker
- > easy handling
- > cutting width: 7/64" (2.7 mm)
- > tool body: special tool steel, rolled, oil-hardened
- > blades: special tool steel, oil-hardened, interchangeable



Notching and chip breaking in a single pass

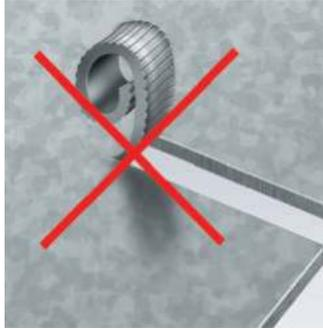

Notching without chip breaking



90 55 280



WARNING: This product can expose you to chemicals including Nickel, which is known to the State of California to cause cancer. For more information go to www.P65Warnings.ca.gov

Product Number	Packaging	↔ Inch mm		Tool	Handles	⚖ lbs
90 55 280		11 280		nickel plated	multi-component grips	1.02
90 59 280	Spare blade for 90 55 280					

Notching Pliers

90
61

- > special pliers for notching out recesses in plastic ledges and plastic casing boxes for electric and sanitary installation
- > notches can be enlarged by initial and final cut
- > clean cut edges
- > easy handling
- > with opening spring, opening limiter and locking lever
- > pliers body: special tool steel, rolled, oil-hardened



90 61 20

 (PATENTED)



The KNIPEX Notching Pliers produce the most common notches in plastic ledges and cable ducts in a simple, fast and clean way. No time-consuming sawing out or nibbling and no additional work required.

Product Number	Packaging	↔ Inch mm		Pliers	Handles	Capacity	⚖ lbs
90 61 16		10 250		burnished	plastic grips	5/8 x 1 1/4 Inch 16 x 32 mm	0.89
90 61 20		10 250				25/32 x 1 9/64 Inch 20 x 29 mm	0.91

Revolving Punch Pliers

90
7

- > for punching holes in leather, textiles and plastic material
- > with six rotating punches: 5/64", 3/32", 1/8", 9/64", 5/32", 13/64" (2.0/2.5/3.0/3.5/4.0/5.0 mm) dia.
- > with opening spring and locking lever
- > powder-coated for reliable protection against rust
- > pliers body and punches: special tool steel, oil-hardened



Interchangeable punches



90 70 220
MM

Product Number	Packaging	↔ Inch mm		Pliers	Finish	⚖ lbs
90 70 220	X	8 3/4 220	MM	red powder-coated	powder-coated	0.55

Tile Nibbling Pincer

Parrot beak pincer

91
0

- > enlarges holes in tiles and forms tile edges
- > special tool steel; forged, oil-hardened



91 00 200

Product Number	Packaging	↔ Inch mm	Pliers	Head	⚖ lbs
91 00 200		8 200	black atramentized	polished	0.35

Work without cutting-off machine, particularly for fine strips.
For less mess, dust, noise and effort.

For the precise cutting (breaking) of tiles and porcelain stoneware after scoring with a tile cutter

Ideal for long and thick tiles

- > parallel jaws evenly distribute force that is 10x your strength
- > a precise cut of floor or wall tiles after scoring with a tile cutter
- > replaceable plastic positioning jaw tilts for a clean break line and optimum protection of the tiles against damage
- > chrome vanadium electric steel, forged, oil-hardened



91 13 250



Product Number	Packaging	↔ Inch mm		Pliers	Handles	Adjustment positions	⚖ lbs
91 13 250		10 250		chrome plated	plastic coated	17	1.29
91 19 250 01	Spare jaw for 91 13 250						

Glass Breaking Pincer

DIN ISO 5743

- > for breaking glass on a scored line
- > special tool steel; forged, oil-hardened



91 31 180



Product Number	Packaging	↔ Inch mm		Pliers	Head	Handles	Jaw width Inch mm	⚖ lbs
91 31 180		7 1/4 180		black atramentized	polished	plastic coated	15/16 24	0.52

Glass Nibbling Pincers

DIN ISO 5743

91

- > for breaking off narrow strips of glass to a scored line
- > for finishing off glass edges to required profile
- > special tool steel; forged, oil-hardened



91 51 160

91 71 160

Narrow version, with opening spring

Product Number	Packaging	↔ Inch mm		Pliers	Head	Handles	Jaw width Inch mm	⚖ lbs
91 51 160		6 1/4 160		black atramentized	polished	plastic coated	3/8 9.5	0.33
91 71 160		6 1/4 160		black atramentized	polished	plastic coated	5/32 4.0	0.31

Flat Nose Grozing Pliers

DIN ISO 5743

91

6

- > with soft gripping jaws
- > for trimming glass edges, e. g. when making leaded glass windows
- > special tool steel; forged, oil-hardened



91 61 160

Product Number	Packaging	↔ Inch mm		Pliers	Head	Handles	Jaw width Inch mm	⚖ lbs
91 61 160		6 1/4 160		black atramentized	polished	plastic coated	3/8 9.5	0.31

Hog Ring Pliers

91

92

- > for the professional replacement of automotive upholstery to the seat frame compatible with all popular upholstery rings or hog rings
- > recessed groove located in the jaws securely hold the hog rings in the proper position before they are crimped
- > closing spring holds the pliers closed which allows for the ring to be securely positioned before being compressed
- > high transmission ratio allows for easy compression of the hog rings
- > multi-component grips for added hand comfort
- > durable and strong
- > special tool steel; forged, oil-hardened



91 92 180



Reliable use for repairs to car seats, e.g. to renew seat cover, replace sensor or seat heating mats

Product Number	Packaging	↔ Inch mm		Pliers	Handles	⚖ lbs
91 92 180		7 1/4 185		mirror-polished	multi-component grips	0.43

- > smooth gripping surfaces
- > non-reflective matte finish

92 02 53

For SMD-technology*; angled tips, width approx. 3/64" (1 mm); gripping surfaces matte finish for optimum grip; Chrome nickel steel: stainless, anti-magnetic (18/10), very popular electronics quality



92 02 53
 $\angle 45^\circ$

92 02 54

For SMD-technology*; angled tips, width approx. 3/64" (1 mm) dia.; with integrated profile for reliable gripping of cylindrical components of approx. 1/32" (0.6 mm) dia.; gripping surfaces matte finished for optimum grip; Chrome nickel steel: stainless, anti-magnetic (18/10), very popular electronics quality



92 02 54
 $\angle 45^\circ$

92 02 55

Gripping jaws 9/64" (3.5 mm) wide, for cylindrical components of 1/8" (0.8 mm) dia.; serrated handles; stainless, anti-magnetic and acid-proof



92 02 55
 \square

92 12 52

Bent tips; extra strong tips; stainless, anti-magnetic



92 12 52
 $\angle 85^\circ$

Product Number	Packaging	\leftrightarrow Inch mm		Finish	\triangle lbs
92 02 53		4 3/4 120	$\angle 45^\circ$	stainless, anti-magnetic	0.04
92 02 54		4 3/4 120	$\angle 45^\circ$	stainless, anti-magnetic	0.03
92 02 55		4 1/2 115	\square	stainless, anti-magnetic, acid-proof	0.04
92 12 52		4 3/4 120	$\angle 85^\circ$	stainless, anti-magnetic	0.04

* SMD-Technology: technique for soldering surface mounted components on printed circuit boards without using holes

- > chrome nickel steel: stainless, anti-magnetic (18/10), very popular electronics quality
- > ESD coating: non-reflective black, with a surface resistance of approx. 10⁵ Ohm
- > tips non-reflective brushed
- > gripping surfaces matte finish for optimum grip

92 08 78 ESD

For SMD-technology*; bent tips; smooth gripping surfaces

92 08 79 ESD

Shaped to grip horizontal cylindrical components of 3/64" (1 mm) dia.; Smooth gripping surfaces; serrated handles

92 28 69 ESD

Straight tips; strong tip; smooth gripping surfaces

92 28 70 ESD

Straight tips; fine tip; smooth gripping surfaces

92 28 71 ESD

Needle-pointed tips; straight tips; smooth gripping surfaces

92 28 72 ESD

Solid; long tips; straight tips; smooth gripping surfaces

92 38 75 ESD

Sickle-shaped tips; smooth gripping surfaces

92 58 74 ESD

Round tips, approx. 5/64" (2 mm) wide; straight tips; smooth gripping surfaces

92 78 77 ESD

Round tips, approx. 9/64" (3.5 mm) wide; straight tips; serrated gripping surfaces; serrated handles

92 88 73 ESD

Rectangular tips, approx. 1/32" (0.9 mm) wide; gripping surfaces with fine transverse serration



92 08 78 ESD



92 08 79 ESD



92 28 69 ESD



92 28 70 ESD



92 28 71 ESD



92 28 72 ESD



92 38 75 ESD



92 58 74 ESD



92 78 77 ESD



92 88 74 ESD



Product Number	Packaging	↔ Inch mm		Finish	⚖ lbs
92 08 78 ESD		4 3/4 120		stainless, anti-magnetic, electrically dissipative	0.04
92 08 79 ESD		4 3/4 120		stainless, anti-magnetic, electrically dissipative	0.04
92 28 69 ESD		5 1/8 130		stainless, anti-magnetic, electrically dissipative	0.04
92 28 70 ESD		4 1/4 110		stainless, anti-magnetic, electrically dissipative	0.03
92 28 71 ESD		4 1/4 110		stainless, anti-magnetic, electrically dissipative	0.04
92 28 72 ESD		5 1/4 135		stainless, anti-magnetic, electrically dissipative	0.05
92 38 75 ESD		4 3/4 120		stainless, anti-magnetic, electrically dissipative	0.04
92 58 74 ESD		4 3/4 120		stainless, anti-magnetic, electrically dissipative	0.04
92 78 77 ESD		5 3/4 145		stainless, anti-magnetic, electrically dissipative	0.06
92 88 73 ESD		5 1/8 130		stainless, anti-magnetic, electrically dissipative	0.04

* SMD-Technology: technique for soldering surface mounted components on printed circuit boards without using holes

Precision Tweezers with pointed shape

92

- > for fine mounting work
- > straight tips
- > smooth gripping surfaces
- > particularly slim tips

92 22 04

Non-reflective matte finish; gripping surfaces matte finish for optimum grip; Chrome nickel steel: stainless, anti-magnetic (18/10), very popular electronics quality

92 22 06

Non-reflective matte finish; gripping surfaces matte finish for optimum grip; Chrome nickel steel: stainless, anti-magnetic (18/10), very popular electronics quality

92 22 07

Non-reflective matte finish; stainless, anti-magnetic and acid-proof

92 23 05

TITANIUM; electrically conductive; lightweight; non-reflective matte finish; stainless, anti-magnetic and acid-proof

92 24 01

Mirror finish nickel plated and polished



92 22 04



92 22 06



92 22 07



92 23 05



92 24 01



Product Number	Packaging	↔ Inch mm		Finish	⚖ lbs
92 22 04		5 1/8 130	✳️ ◻	stainless, anti-magnetic	0.04
92 22 06		4 3/4 120	✳️ ◻	stainless, anti-magnetic	0.04
92 22 07		4 1/2 115	✳️ ◻	stainless, anti-magnetic, acid-proof	0.03
92 23 05		4 3/4 120	✳️ ◻	TITANIUM, anti-magnetic, acid-proof, stainless	0.02
92 24 01		4 3/4 120	✳️ ◻	chrome plated	0.04

Precision Tweezers with needle-pointed shape

92

- > for ultra fine mounting work
- > extra fine tips
- > smooth gripping surfaces
- > stainless, anti-magnetic
- > non-reflective matte finish

92 22 12

Straight tips

92 22 13

Solid; straight tips; stainless, anti-magnetic and acid-proof

92 32 29

Sickle-shaped tips; Chrome nickel steel: stainless, anti-magnetic (18/10), very popular electronics quality; gripping surfaces matte finish for optimum grip

92 34 28

Bent tips



92 22 12



92 22 13



92 32 29



92 34 28



Product Number	Packaging	↔ Inch mm		Finish	⚖ lbs
92 22 12		4 105	✳️ ◻	stainless, anti-magnetic	0.03
92 22 13		4 3/4 120	✳️ ◻	stainless, anti-magnetic, acid-proof	0.06
92 32 29		4 3/4 120	✳️ ∠45° ◻	stainless, anti-magnetic	0.04
92 34 28		4 105	✳️ ∠45° ◻	stainless, anti-magnetic	0.03

Precision Tweezers

with dowel pin, pointed shape

92

- > universal application
- > narrow tips
- > gripping surfaces with fine transverse serration
- > serrated handles

92 22 35

Straight tips; non-reflective matte finish; stainless, anti-magnetic and acid-proof

92 24 34

Straight tips; chrome plated

92 34 36

Bent tips; chrome plated

92 34 37

Bent tips; black non-reflective lacquered

92 22 35



92 24 34



92 34 36



92 34 37



Product Number	Packaging	↔ Inch mm		Finish	⚖ lbs
92 22 35		6 155		stainless, anti-magnetic, acid-proof	0.05
92 24 34		6 155		chrome plated	0.05
92 34 36		6 155		chrome plated	0.05
92 34 37		6 155		black lacquered	0.05

Precision Tweezers Insulated

IEC 60900 DIN EN 60900

92

- > insulated and tested according to IEC 60900 : ASTM F1505
- > plastic dipped insulated
- > nickel plated
- > spring steel, high-strength

92 27 61

For ultra fine mounting work; extra fine tips; straight tips; gripping surfaces matte finish for optimum grip

92 27 62

Straight tips; gripping surfaces with fine transverse serration

92 37 64

Bent tips; gripping surfaces with fine transverse serration

92 67 63

Straight tips; serrated gripping surfaces

92 27 61



92 27 62



92 37 64



92 67 63



Product Number	Packaging	↔ Inch mm		Finish	⚖ lbs
92 27 61		5 1/8 130		plastic dipped insulated, VDE-tested	0.07
92 27 62		6 150		plastic dipped insulated, VDE-tested	0.08
92 37 64		6 150		plastic dipped insulated, VDE-tested	0.08
92 67 63		5 3/4 145		plastic dipped insulated, VDE-tested	0.10

Precision Tweezers

with blunt shape

92

- > universal application
- > straight tips
- > wide, round tips
- > serrated handles

92 44 42

Jewelers tweezer; round tips, approx. 5/64" (2 mm) wide; gripping jaws with fine cross-hatched serration (cross cut); nickel plated

92 64 43

Round tips, approx. 1/8" (3 mm) wide; gripping surfaces with fine transverse serration; chrome plated

92 64 44

Round tips, approx. 9/64" (3.5 mm) wide; gripping surfaces with fine transverse serration; chrome plated

92 70 46

Round tips, approx. 9/64" (3.5 mm) wide; gripping surfaces with fine transverse serration; black non-reflective lacquered

92 72 45

Round tips, approx. 9/64" (3.5 mm) wide; serrated gripping surfaces; non-reflective matte finish; stainless, anti-magnetic and acid-proof



92 44 42



92 64 43



92 64 44



92 70 46



92 72 45



Product Number	Packaging	↔ Inch mm		Finish	⚖ lbs
92 44 42		5 1/2 140		nickel plated	0.05
92 64 43		4 3/4 120		chrome plated	0.04
92 64 44		5 3/4 145		chrome plated	0.06
92 70 46		5 3/4 145		black lacquered	0.06
92 72 45		5 3/4 145		stainless, anti-magnetic, acid-proof	0.06

Precision Tweezers

round slim shape

92

- > round tips, approx. 5/64" (2 mm) wide
- > smooth gripping surfaces
- > chrome nickel steel: stainless, anti-magnetic and acid-proof



92 52 23



Product Number	Packaging	↔ Inch mm		Finish	⚖ lbs
92 52 23		4 3/4 120		stainless, anti-magnetic, acid-proof	0.04

Plastic Tweezers

92

- > trapezoid shaped tips, approx. 9/64" (3.5 mm) wide
- > serrated gripping surfaces
- > serrated handles
- > tweezers body: solid plastic, temperature-resistant up to 266° F



92 69 84



Product Number	Packaging	↔ Inch mm		Finish	⚖ lbs
92 69 84		5 1/4 130		plastic	0.02

Precision Tweezers

rectangular blunt

92

- > mounting tweezer
- > rectangular tips, approx. 1/32" (0.9 mm) wide
- > gripping surfaces with fine transverse serration
- > chrome plated
- > spring steel, high-strength



92 84 18



Product Number	Packaging	↔ Inch mm		Finish	⚖ lbs
92 84 18		5 125		chrome plated	0.04

Crossover Tweezers

92

- > for holding small parts without finger pressure
- > for efficient clamping
- > chrome plated
- > spring steel, high-strength



92 94 91



92 94 91

Trapezoid shaped, straight tips; gripping surfaces with fine transverse serration; serrated handles

92 95 90

Narrow, bent tips; gripping surfaces with fine transverse serration; handles with plastic attachment



92 95 89



92 95 89

Narrow, straight tips; gripping surfaces with fine transverse serration; handles with plastic attachment



92 95 90



Product Number	Packaging	↔ Inch mm		Finish	⚖ lbs
92 94 91		6 1/4 160		chrome plated	0.08
92 95 89		6 1/4 160		chrome plated	0.07
92 95 90		6 1/4 160		chrome plated	0.07

Cutter for ribbon cable

94
15

- > for crush-free cutting of ribbon cable up to 2 13/64" (56 mm) width
- > exchangeable cutting base with fence angle for rectangular cuts
- > with opening spring and locking lever
- > tool body: tool steel, rolled, oil-hardened
- > blade: standard trapezoidal blade, replaceable



94 15 215



WARNING: This product can expose you to chemicals including Diisononyl Phthalate, which is known to the State of California to cause cancer. For more information go to www.P65Warnings.ca.gov

Product Number	Packaging	↔ Inch mm		Tool	Handles	Blade length Inch mm	⚖ lbs
94 15 215		8 1/2 215		chrome plated	plastic coated	2 13/64 56	0.76
94 19 215	10 spare blades for 94 15 215 / 94 35 215						

Mitre Shears for plastic and rubber sections

94
3

- > for crush-free cutting of plastic, rubber and soft timber sections; also for ribbon cable up to 2 13/64" (56 mm) width
- > exchangeable cutting base with fence angle for 45°-cuts and markings for 60°, 75°, and 90°-cuts
- > with opening spring and locking lever
- > tool body: special tool steel, rolled, oil-hardened
- > blade: standard trapezoid shaped blade, replaceable



94 35 215



WARNING: This product can expose you to chemicals including Diisononyl Phthalate, which is known to the State of California to cause cancer. For more information go to www.P65Warnings.ca.gov

Product Number	Packaging	↔ Inch mm		Tool	Handles	Blade length Inch mm	⚖ lbs
94 35 215		8 1/2 215		chrome plated	plastic coated	2 13/64 56	0.86
94 19 215	10 spare blades for 94 15 215 / 94 35 215						

Vinyl Shears

for cable ducts

95
02

- > for cutting and shortening cable ducts and for plastic material up to 5/32" (4.0 mm) thickness
- > special lever transmission
- > very effective blade geometry
- > tool body: high-grade chrome vanadium electric steel, oil-hardened
- > blade: special tool steel; oil-hardened



95 02 21
 PATENTED

95 02 21: Blade length 4 1/4" (110 mm) for cutting wide cable ducts

Product Number	Packaging	↔		Tool	Handles	Cutting capacities		Blade length		⚖ lbs
		Inch	mm			Inch	mm	Inch	mm	
95 02 21		11	275	 burnished	multi-component grips	5/32	4.0	4 1/4	110	1.47

Anvil Shears

for cutting soft material such as rubber and leather

94

- > includes opening spring and locking device
- > cutting capacity for round material up to 1" (25 mm)
- > cuts flat material up to 1.50" (40 mm) max. width
- > tool body constructed of rolled and oil-hardened tool steel



94 55 200

Part Number	↔		Pliers	Handles	Cutting Capacity	⚖ lbs
	inch	mm				
94 55 200	8	200	chrome plated	plastic coated	soft material - rubber, leather and hoses	0.64
95 59 200 01	Spare blade for 94 55 200					

Shears for KEVLAR® fibers

95
03



- > only for cutting fibers of KEVLAR® in optical fiber cables, not recommended for other materials
- > precision ground blades with serration prevent the fibers from slipping and guarantees a clean cut
- > riveted precision joint, for low-friction movement and smooth and even cutting of the thin KEVLAR® fibers
- > hard chrome plated, ground surface
- > shears body: chrome vanadium electric steel, oil-hardened
- > user-friendly handles: plastic, impact-resistant



95 03 160 SB

KEVLAR® is a registered trademark of E. I. du Pont de Nemours and Company

Product Number	Packaging	↔ Inch mm	Shears	Handles	⚖ lbs
95 03 160 SB		6 1/4 160	chrome plated	plastic coated	0.15

Combination Shears

95
05

- > for cutting cardboard, plastics, aluminum, brass and copper foils
- > not suitable for steel wire or iron sheets
- > precision ground, hardened blades
- > with opening spring and locking device
- > pinch guard prevents operators' fingers being pinched
- > adjustable bolted joint
- > shears body: surgical steel, stainless, air-hardened
- > handles: plastic, impact-resistant

95 05 185

Angled shape – for easy execution of long cuts;
ergonomically shaped plastic handles

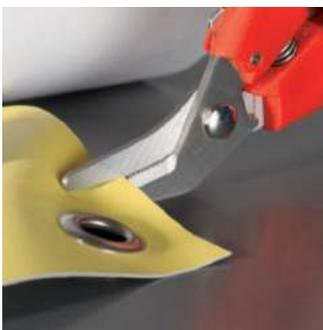

95 05 140
MM



95 05 185
∠40° MM



95 05 190
MM

WARNING: This product can expose you to chemicals including lead, which is known to the State of California to cause cancer. For more information go to www.P65Warnings.ca.gov

Product Number	Packaging	↔ Inch mm	Head	Handles	⚖ lbs
95 05 140		5 1/2 140	MM	plastic coated	0.15
95 05 185		7 1/4 185	∠40° MM	plastic coated	0.25
95 05 190		7 1/2 190	MM	plastic coated	0.26

Precision ground blades with fine serration for a clean, non-slip cut
Cutting edge with integrated cable cutter
With plastic belt case

- > universal shears for electricians
- > handles with multi-component grips, fiberglass-reinforced
- > cutting edges made from stainless steel, hardness of cutting edges 56 HRC

95 05 10 SB

With crimp area for end sleeves (ferrules) up to 6.0 mm²

95 05 155 SBA

WARNING: This product can expose you to chemicals including lead, which is known to the State of California to cause cancer. For more information go to www.P65Warnings.ca.gov

95 05 10 SB



Product Number	Packaging	↔ Inch mm	Head	Handles	Capacity mm ²	⚖ lbs
95 05 155 SBA	X	6 1/8 155	polished	multi-component grips, fiberglass-reinforced	-	0.24
95 05 10 SB	X	6 1/4 160	polished	multi-component grips, fiberglass-reinforced	6.0	0.31

Cable Shears

- > not suitable for steel wire and hard drawn copper conductors
- > precision ground, hardened blades
- > no crushing, slight deformation of the cable only
- > pinch guard prevents operators' fingers being pinched
- > adjustable bolted joint
- > shears body: surgical steel, stainless, vacuum-hardened
- > handles: plastic, impact-resistant

95 05 165

Cuts cables up to 25/64" diameter (10 mm, 24 mm²); with opening spring and locking device; blades made of stainless steel; oil-hardened and tempered

95 06 230

For copper conductors single wire up to 5/8" (16 mm²), stranded up to 1/0 AWG (50 mm²), fine stranded up to 2/0 (70 mm²) and aluminum conductors multi wire up to 70 mm²; easy cutting with one-hand operation due to high transmission ratio; stainless – surgical grade – steel, oil-hardened and tempered



95 05 165
⚡ ⚡ ⚡ ⚡



95 06 230
⚡ 1000V ⚡ ⚡ ⚡ ⚡

Product Number	Packaging	↔ Inch mm	Head	Handles	Cutting capacities			⚖ lbs	
					⚡ Ø Inch Ø mm	⚡ mm ²	AWG		
95 05 165		6 1/2 165	⚡ ⚡ ⚡ ⚡	polished	plastic coated	25/64 10	24	6	0.25
95 06 230		9 1/4 230	⚡ 1000V ⚡ ⚡ ⚡ ⚡	polished	plastic insulated, VDE-tested	5/8 16	50	solid - 1/0 stranded - 2/0	0.60

- > for cutting copper and aluminum cables, single and multi-stranded wire
- > not suitable for steel wire and hard drawn copper conductors
- > precision ground, hardened blades
- > clean and smooth cut without crushing and deformation
- > easy cutting with one-hand operation
- > pinch guard prevents operators' fingers being pinched
- > adjustable bolted joint, self-locking
- > high-grade special tool steel; forged, oil-hardened

Style 2

Internal opening spring, protected and captive

Style 4

Multifunctional tool for working on NYM cable from 3 x 1.5 mm² to 5 x 2.5 mm² (cutting, stripping insulation); universal stripping area for both solid conductor cross-sections; reliable alignment of the cable in the stripping area due to V-shaped blade geometry

95 12 165 T BKA*

Pliers with integrated tether attachment point for tool drop protection system



Cut performed with a Diagonal Cutter: high effort required, inaccurate cut, considerable deforming and crushing of the cable



Cut performed with a Cable Shear: easy, clean cut without any deformation of the cable



The locking device keeps shears with spring inside the joint closed



95 11 165



95 12 165



95 12 165 T BKA



95 18 165 US
1000 V ASTM



95 21 165



95 41 165

Product Number	Packaging	↔ Inch mm	Icons	Tool	Handles	Style	Cutting capacities			⚖ lbs
							⊕ Ø Inch Ø mm	⊕ mm ²	AWG	
95 11 165	X	6 1/2 165	⊕ ⊕	burnished	plastic coated	1	19/32 15	50	1/0	0.49
95 12 165	X	6 1/2 165	⊕ ⊕	burnished	multi-component grips	1	19/32 15	50	1/0	0.55
95 12 165 T BKA	X	6 1/2 165	⊕ ⊕	burnished	multi-component grips, integrated tether attachment point	1	19/32 15	50	1/0	0.56
95 18 165 US	X	6 1/2 165	⚠ 1000 V ASTM ⊕	burnished	insulated, multi-component grips, ASTM-tested	1	19/32 15	50	1/0	0.58
95 21 165	X	6 1/2 165	⊕ ⊕	burnished	plastic coated	2	19/32 15	50	1/0	0.50
95 22 165		6 1/2 165	⊕ ⊕	burnished	multi-component grips	2	19/32 15	50	1/0	0.56
95 41 165		6 1/2 165	⊕ ⊕	burnished	plastic coated	4	15/32 12	35	1/0	0.49

*Learn more about our tethered tool system on pages 207-211

Cable Shears

with twin cutting edge

95
1

- > for cutting copper and aluminum cables
- > not suitable for steel wire and hard drawn copper conductors
- > precision ground, hardened blades
- > clean and smooth cut without crushing and deformation
- > by dividing the cutting actions into initial cut (insulating sheath in the front cutting area) and final cut (conductor in the back cutting area), cables up to 25/32" (20 mm) dia. can be cut in one-hand operation
- > less effort required due to favorable lever ratio and optimized cutting-edge geometry
- > pinch guard prevents operators' fingers being pinched
- > adjustable bolted joint, self-locking
- > high-grade special tool steel; forged, oil-hardened



Initial cut: using the front cutting edge to cut the insulating sheath on larger cable diameters leaves an ergonomic handle opening width.



Final cut: after cutting the sheath in the front profile the conductors are cut in the rear area.



95 11 200
PATENTED



95 12 200
PATENTED



95 18 200 SBA
1000 V ASTM PATENTED

The twin cutting edge allows a comfortable handle position in all cutting situations inside the specified cutting capacity.

Product Number	Packaging	↔ Inch mm		Tool	Handles	Cutting capacities		AWG	⚖ lbs
						⊘ Inch ⊘ mm	⊘ mm ²		
95 11 200	X	8 200	⊕ ⚡	burnished	plastic coated	25/32 20	70	2/0	0.65
95 12 200	X	8 200	⊕ ⚡	burnished	multi-component grips	25/32 20	70	2/0	0.74
95 18 200 SBA	X	8 200	⊕ ⚡ ⚠ 1000 V ASTM	burnished	insulated, multi-component grips, ASTM-tested	25/32 20	70	2/0	0.75

Cable Shears

95

Short design, length only 20" (500 mm)
Lightweight, high leverage

- > for cutting copper and aluminum cables, single and multi-stranded wire
- > not suitable for steel wire and wire ropes
- > precision ground, hardened blades
- > clean and smooth cut without crushing and deformation
- > less effort required due to favorable lever ratio and special blade geometry
- > pinch guard prevents operators' fingers being pinched
- > adjustable bolted joint
- > cutter head: vanadium electric steel, forged, oil-hardened
- > handle shank: aluminum tube, high-strength



Large cutting capacity: max. 1 1/16"
(27 mm) dia. / 150 mm²



95 12 500
⚡ ⚠



95 17 500
⚡ 1000 V ⚠ ⚡ ⚠ ⚡ ⚠

Product Number	Packaging	↔ Inch mm	⚡ ⚠	Head	Handles	Cutting capacities		AWG	⚖ lbs
						⚡ Ø Inch Ø mm	⚡ mm ²		
95 12 500		20 500	⚡ ⚠	polished	multi-component grips	1 1/16 27	150	5/0	2.49
95 17 500		20 500	⚡ 1000 V ⚠ ⚡ ⚠	polished	plastic dipped insulated, VDE-tested	1 1/16 27	150	5/0	3.26

Cable Shears

95

- > for cutting copper and aluminum cables, single and multi-stranded wire
- > not suitable for steel wire and wire ropes
- > precision ground, hardened blades
- > clean and smooth cut without crushing and deformation
- > favorable lever ratio due to toggle lever
- > pinch guard prevents operators' fingers being pinched
- > adjustable bolted joint
- > bolted cutter head, replaceable
- > blade head: high-grade chrome vanadium electric steel, forged, oil-hardened
- > handle: steel tube



95 27 600
⚡ 1000 V ⚠ ⚡ ⚠ ⚡ ⚠

Product Number	Packaging	↔ Inch mm	⚡ ⚠	Head	Handles	Cutting capacities		AWG	⚖ lbs
						⚡ Ø Inch Ø mm	⚡ mm ²		
95 27 600		23 1/2 600	⚡ 1000 V ⚠ ⚡ ⚠	polished	plastic dipped insulated, VDE-tested	1 1/16 27	150	5/0	5.08
95 29 600	Spare cutter head for 95 27 600								

- > for cutting copper and aluminum cables, single and multi-stranded wire
- > not suitable for steel wire and wire ropes
- > precision ground, hardened blades
- > clean and smooth cut without crushing and deformation
- > one-hand operation using ratchet principle
- > minimal handforce required due to very high transmission ratio
- > two-stage ratchet drive for easy cutting
- > simple handling as a result of lightweight and compact design – can be used even in confined areas
- > pinch guard prevents operators' fingers being pinched
- > high-grade special tool steel; forged, oil-hardened



95 31 250 SBA



95 31 280 SBA



95 36 250 SBA



95 31 280: Large cutting capacity:
max. 2" (52 mm) dia. / 380 mm²



Ratchet principle and two-stage ratchet drive
for easier cutting



95 31 250/280: Fixed handle with support area as an aid to position the pliers when cutting

Product Number	Packaging	↔ Inch mm		Tool	Handles	Cutting capacities			⚖ lbs
						⊕ Ø Inch Ø mm	⊕ mm ²	MCM	
95 31 250 SBA	X	10 250	⊕ MM ⊕	black lacquered	multi-component grips	1 1/4 32	240	500	1.49
95 31 280 SBA	X	11 280	⊕ MM ⊕	black lacquered	multi-component grips	2 3/64 52	380	750	1.70
95 36 250 SBA	X	10 250	⚠ 1000V ⊕ ⊕ ⊕ MM ⊕	black lacquered	insulated, multi-component grips, VDE-tested	1 1/4 32	240	500	1.24
95 36 280 SBA	X	11 280	⚠ 1000V ⊕ ⊕ ⊕ MM ⊕	black lacquered	insulated, multi-component grips, VDE-tested	2 3/64 52	380	750	1.64
95 39 250	Movable spare blade for 95 31 250 / 95 36 250								
95 39 280	Movable spare blade for 95 31 280 / 95 36 280								

Cable Shears

with ratchet action and telescopic handles

95
32

Cable shears with adjustable telescopic handles allow angular positioning

- > for cable diameters up to 1 1/2" (38 mm), handles can be positioned at an angle to set the optimum handle width, great for work in confined areas
- > comfortable work due to ratchet action and lightweight
- > heavy-duty telescopic handles made of oval aluminum tubing; extendable up to 30" (770 mm) for maximum leverage on large cable diameters; retractable down to 22" (570 mm) for minimum space requirements during transport
- > replaceable cutting head
- > extensive cutting range up to 1 1/2" (38 mm) dia. or 550 MCM (280 mm²) in copper and aluminum cables
- > easier, neater cut due to optimized cutting edge geometry
- > adjustable bolted joint
- > cutting head: special quality, high-grade tool steel, oil-hardened
- > handles: high-strength oval aluminum tubing



95 32 038

Handles are adjustable in length and angular position for easier work. Set the handle length to the optimum position for powerful cutting; put the handles at an angle for a comfortable gripping position.



Setting of a favorable handle width



After the first partial cut, the handles open by ratchet action



Thorough cut of the cable by repeat cutting and opening actions

WARNING: This product can expose you to chemicals including Diisononyl Phthalate, which is known to the State of California to cause cancer. For more information go to www.P65Warnings.ca.gov

Product Number	Packaging	↔ Inch mm	Head	Handles	Cutting capacities			
					⊕ Ø Inch Ø mm	⊕ mm ²	MCM	⚖ lbs
95 32 038		22 7/16 570	⊕ burnished	multi-component grips	1 1/2 38	280	550	4.49

Cable Cutters

with ratchet action and telescopic handles

95
32

- > for copper and aluminum cables, single and multi-stranded wire – also with hard rubber, plastic sheet metal sheath
- > not suitable for steel wire and wire ropes
- > minimal handforce required for cutting due to optimum transmission ratio
- > high cutting capacity due to two-handed operation and ratchet action
- > the blade can be opened in any cutting position
- > adjust the handle length to adapt to each individual job and move it to the shorter length for easy transport
- > blade: special-quality high-grade tool steel, oil-hardened
- > handles: high-strength oval aluminum tubing



95 32 060



WARNING: This product can expose you to chemicals including Diisononyl Phthalate, which is known to the State of California to cause cancer. For more information go to www.P65Warnings.ca.gov

95 32 060

Tool length: 23 5/8" - 31 1/2" (600 - 800 mm)

95 32 100

Tool length: 25 1/2" - 33 7/8" (650 - 850 mm)

Product Number	Packaging	↔ Inch mm	Head	Handles	Cutting capacities			MCM	⚖ lbs
					⊘ Inch Ø mm	⊘ mm ²			
95 32 060		23 5/8 - 31 1/2 600 - 800	⊕ burnished	multi-component grips	2 3/64 60	740	1400	8.47	
95 32 100		25 1/2 - 33 7/8 650 - 850 mm			3 15/16 100	960	1900	10.98	
95 39 720	Movable spare blade for 95 32 060								
95 39 870	Movable spare blade for 95 32 100								



Cable Cutters (ratchet action)

for steel wire armored cable (SWA-Cable)

95

Cuts through steel wire armored cable with a diameter of up to 45 mm / 380 mm² (e.g. 4 x 95 mm²) using one or two-handed operation

- > simple handling due to lightweight (1.82 lbs) and compact design (315 mm length) – can also be used in confined areas
- > precision ground blades and induction hardened cutting edges cut smoothly and neatly without crushing
- > innovative high leverage three-stage ratchet-drive
- > flange on the handle can be used as a support surface when cutting larger diameters
- > high-grade special tool steel, forged, oil-hardened
- > not suitable for cutting ACSR cable and wire rope!



Precision milled and induction hardened cutting edge

95 36 315 A
 ⚡ 1000 V ⚠️ ⚙️ ⚙️

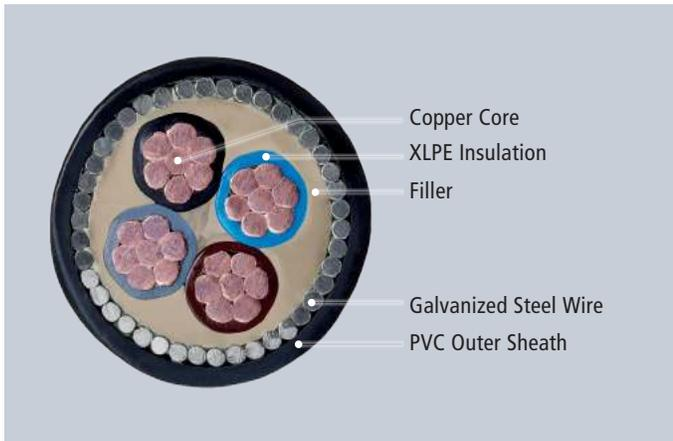

Cross-section of a steel wire armored cable



Product Number	↔ Inch mm	⚡	Tool	Handles	Cutting capacity		MCM	⚖️ lbs
					⊘ mm	mm ²		
95 32 315 A	12 13/32 315	⚡	black lacquered	multi-component grips	45	380	750	1.80
95 36 315 A	12 13/32 315	⚡ 1000 V ⚠️ ⚙️ ⚙️	black lacquered	insulated multi-component grips, VDE-tested	45	380	750	1.80
95 39 315 A 01	Pivot cutter repair kit							
95 39 315 A 02	Fixed cutter repair kit							

Cable Cutters

with ratchet principle, 3-stage

95
3

Sturdy, easy to use and stable Innovative ratchet drive

- > Manual ratchet-action cable cutter for one-hand and two-handed operation for cutting copper and aluminum cables with diameters of up to 2 23/64" (60 mm)
- > easy handling due to light weights (1.82 lbs) and compact construction (12 1/2" / 320 mm length) – suitable for use in confined areas
- > cuts through copper and aluminum cables with diameters of up to 2 23/64" (60 mm) in one-hand and two-handed operation
- > hardened cutting edges, precisely ground, cut smoothly and neatly without crushing
- > for cutting copper and aluminum single conductors as well as multi-stranded cables (not suitable for steel wire and wire ropes)
- > innovative 3-stage ratchet-drive with high leverage for easy cutting in one-hand and two-handed operation
- > flange on the handle can be used as a support surface when cutting larger diameters
- > high-grade special tool steel; forged, oil-hardened



95 32 320



The innovative three gear drive permits three operating modes

- > Fast working with full lift of handles and one-hand operation when cutting through insulation material
- > Powerfully sliding the sickle knife forward when cutting through the stranded conductor with two hands through use of the central lifting area (handle opening of between 1/3 and 2/3 of total range)
- > Powerfully pushing the sickle knife forward with one hand to cut through the stranded conductor through use of the first third of the handle lift with one or two hands

First manual ratchet-action cable cutter for one-hand and two-handed operation for cutting copper and aluminum cables with diameters of up to 2 23/64" (60 mm)!

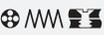
Product Number	Packaging	↔ Inch mm		Tool	Head	Handles	Cutting capacities		MCM	⚖ lbs
							∅ Inch	∅ mm ²		
95 32 320		12 1/2 320		black atramentized	polished	multi-component grips	2 3/64 60	600	1200	1.82
95 36 320		12 1/2 320		black atramentized	polished	insulated, multi-component grips, VDE-tested	2 3/64 60	600	1200	1.83
95 39 320 01	Pivot cutter repair kit for 95 32 320 and 95 36 320									
95 39 320 02	Fixed cutter repair kit for 95 32 320 and 95 36 320									

ACSR Cable Cutter

with ratchet action for cables with a steel core

95
3

Handy, compact and sturdy
Extremely robust design



Enormous power with a weight of just 2.87 lbs (1300 g)



- > cuts ACSR 795 kcmil and AAC up to 1 1/4" (32 mm)
- > cutters with precision cut and induction hardened cutting edges
- > two-stage ratchet drive for easy cutting
- > less physical effort due to very high transmission ratio
- > fixed handle with support area for laying down the pliers when cutting
- > locking mechanism for transporting with safely closed handles
- > high-grade special tool steel; forged, multi stage oil-hardened



95 32 340 SR US



Product Number	Packaging	↔ Inch mm		Tool	Handles	Cutting capacities		⚖ lbs
						AAC (All Aluminum Conductor) Ø Inch Ø mm	ACSR (Aluminum Conductor Steel Reinforced) kcmil	
95 32 340 SR US	X	13 25/64 340		burnished	multi-component grips	1 1/4 32	795	2.87

Bowden Cable Cutter

95
6

- > for Bowden cables and soft wire rope up to 1/8" (3.0 mm) dia. (also V2A)
- > smooth and clean cutting due to special shape of the cutting edges
- > sickle shape cutting edges surround the material and prevent the wire rope fanning out
- > minimal handforce required due to very high transmission ratio
- > with opening spring and locking lever
- > induction hardened cutting edges
- > high-grade special tool steel; forged, multi stage oil-hardened



95 61 150 US



Product Number	Packaging	↔ Inch mm		Shears	Head	Handles	Cutting capacities		⚖ lbs
							Ø Inch Ø mm		
95 61 150 US	X	6 150		black atramentized	polished	plastic coated	1/8 3		0.48

Wire Rope Shears

forged

95
6

Double function: clean cutting, precise crimping

- > with two crimping dies for end caps on Bowden cable sheaths and ferrules for wire rope
- > comfortable work due to slim design and internal opening spring
- > bolted joint for precise blade guidance, readjustable
- > high leverage for reduced effort
- > cutting edge hardness (approx. 64 HRC)
- > chrome vanadium heavy-duty steel; forged, manifold oil-hardened



Crimping of the ferrules onto the traction cable



Crimping of the end caps on the Bowden cable sheath

Precise guidance through a bolted joint



95 61 190



95 62 190



95 62 190 T BKA*

Pliers with integrated tether attachment point for tool drop protection system

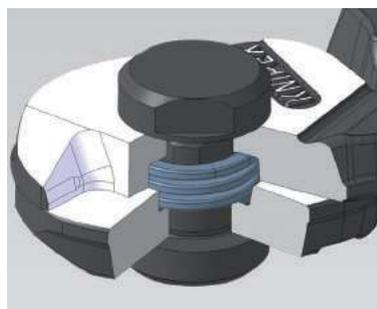

Internal opening spring

Transport lock and opening limiter



Crimp profiles

> Cuts all wire ropes without splaying, including those that are extremely strong
> Not for electrical end ferrules

Product Number	Packaging	↔ Inch mm	Icons	Head	Handles	Cutting capacities				⚖ lbs
						Ø Inch Ø mm	Ø Inch Ø mm	Ø Inch Ø mm	Ø Inch Ø mm	
95 61 190	X	7 1/2 190	⊕ ⊗ ○ ● 🔒 ⚡	polished	plastic coated	9/32 7.0	13/64 5.0	5/32 4.0	3/32 2.5	0.69
95 62 190	X	7 1/2 190	⊕ ⊗ ○ ● 🔒 ⚡	burnished	multi-component grips	9/32 7.0	13/64 5.0	5/32 4.0	3/32 2.5	0.69
95 62 190 T BKA	X	7 1/2 190	⊕ ⊗ ○ ● 🔒 ⚡	burnished	multi-component grips, integrated tether attachment point	9/32 7.0	13/64 5.0	5/32 4.0	3/32 2.5	0.83

Wire Rope Cutter

95

Compact size, lightweight, high performance level
 High transmission joint design makes cutting 20% easier
 Box joint design for greater stability

- > for cutting high-strength wire ropes up to up to 5/32" (4 mm) and cable 3/16" (6 mm)
- > at just 6 1/4" (160 mm) length this tool is considerably more powerful than many larger wire rope cutters
- > included thumb lock and opening spring
- > ball bearing steel for a long service life
- > induction hardened cutting edges
- > cuts cleanly and evenly without wire ends splaying or fanning out



95 62 160



Product Number	Packaging	↔ Inch mm		Head	Handles	⊕ Ø Inch Ø mm	⊙ Ø Inch Ø mm	⚖ lbs
95 62 160	X	6 1/4 160	⊕ ⊙ ⊗ ⊞	polished	multi-component grips	3/16 6.0	5/32 4.0	0.38

Cable Cutters for Wire Rope and ACSR

95

- > for ACSR, wire ropes, steel rods, copper and aluminum cables
- > suitable for cutting overhead cables with strain relief wire
- > angular cutting blades prevent fanning out
- > optimum transmission ratio for high cutting performance
- > bolted cutter head, replaceable
- > lightweight
- > cutter head: high-grade special tool steel, multi stage oil-hardened
- > handles: aluminum, high-strength

95 81 600
 With reinforced cutter head for higher performance, also cuts piano wire



95 71 600



95 77 600

⚠ WARNING: This product can expose you to chemicals including Diisononyl Phthalate, which is known to the State of California to cause cancer. For more information go to www.P65Warnings.ca.gov

Product Number	Packaging	↔ Inch mm		Head	Handles	Cutting capacities				AWG	⚖ lbs
						⊕ mm ²	⊙ Ø Inch Ø mm	◐ Ø Inch Ø mm	● Ø Inch Ø mm		
95 71 445		17 1/2 445	⊕ ⊙ ⊗ ⊞	polished	plastic grips	95	25/64 10	9/32 7	-	3/0	2.39
95 71 600		23 5/8 600	⊕ ⊙ ⊗ ⊞	polished	plastic grips	150	35/64 14	23/64 9	-	5/0	3.84
95 77 600		23 5/8 600	⚡ 1000V ⊕ ⊙ ⊗ ⊞	polished	plastic dipped insulated, VDE-tested	150	35/64 14	23/64 9	-	5/0	5.02
95 81 600		23 5/8 600	⊕ ⊙ ⊗ ⊞	polished	plastic grips	150	5/8 16	25/64 10	11/64 4.5	5/0	4.97

95 79 445	Spare cutter head for 95 71 445
95 79 600	Spare cutter head for 95 71 600 / 95 77 600
95 89 600	Spare cutter head for 95 81 600

- > for cutting cables, stripping wire and crimping insulated and non-insulated terminals, connectors and plug-type connectors
- > with threaded holes for cutting copper and brass screws threaded 7/64", 1/8", 9/64", 5/32" and 13/64" (M2.6, M3, M3.5, M4 and M5)
- > bolted joint for higher stability and smooth movement
- > special steel; high-strength



97 21 215



Product Number	Packaging	↔ Inch mm			Pliers	Handles	Applications	Capacity mm ²	Number of crimping positions	 lbs
97 21 215		9 1/4 235			black lacquered	multi-component grips	Insulated terminals + cable connectors	0.75 - 6.0	3	0.63
97 21 215 B		9 230			black lacquered	multi-component grips	Non-insulated open plug-type connectors (plug width 6.3 mm)	0.5 - 2.5	3	0.63
97 21 215 C		9 230			black lacquered	multi-component grips	Non-insulated terminals + cable connectors	0.5 - 6.0	3	0.63
97 21 215 SB	X	9 1/4 235			black lacquered	multi-component grips	Insulated terminals + cable connectors	0.75 - 6.0	3	0.63
97 22 240		9 1/2 240			black lacquered	multi-component grips	Insulated terminals + cable connectors	0.75 - 6.0	3	0.67
							Non-insulated open plug-type connectors (plug width 6.3 mm)	0.5 - 2.5		

- > just one tool for the most common crimping applications
- > crimping dies change quickly and easily without any additional tool
- > secure and protected storage of the interchangeable dies in a round magazine
- > comfortable, powerful crimping pliers
- > same reliable crimping results as with fixed crimping dies
- > repetitive, high crimping quality due to precision dies and integral lock (self-releasing mechanism)
- > chrome vanadium electric steel in special quality; oil-hardened
- > round magazine: plastic, fiberglass-reinforced



1. Changing position: service lever opens out for parallel jaw positioning



2. Changing the crimp die: unlock the magazine position, take the crimp dies out of the pliers



3. Fold in the service lever and press the pliers – ready for use again



97 33 01



97 33 01

Crimping Pliers with round magazine and three interchangeable crimping dies for:

- > non-insulated open plug-type connectors (4.8 + 6.3 mm width) from 1/64-15/64" (0.5 - 6.0 mm²)
- > insulated terminals, plug connectors and butt connectors from 1/64-15/64" (0.5 - 6.0 mm²)
- > insulated and non-insulated ferrules (end sleeves) from 1/64-15/64" (0.25 - 6 mm²)

Now also for insulated and non-insulated end sleeves (ferrules) 10, 16, 25 mm²
Universal indent crimping die for non-insulated connectors

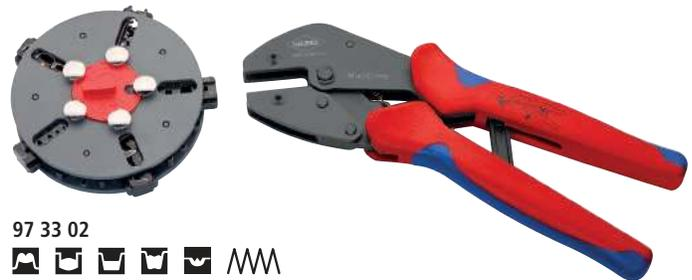

97 33 02



97 33 02

Crimping Pliers with round magazine and five interchangeable dies for:

- > non-insulated open plug-type connectors (plug width 4.8 + 6.3 mm) from 1/64-15/64" (0.5 - 6.0 mm²)
- > insulated terminals, plug connectors and butt connectors from 1/64-15/64" (0.5 - 6.0 mm²)
- > - insulated and non-insulated ferrules (end sleeves) from 1/64-15/64" (0.25 - 6 mm²)
- > insulated and non-insulated ferrules (end sleeves) with 10 / 16 / 25 mm² and for non-insulated crimp terminals
- > tube and compression cable lugs in accordance with DIN 46234 and DIN 46235
- > non-insulated crimp, butt and press connectors in accordance with DIN 46341 and DIN 46267

Compact and lightweight crimping pliers for connectors.
One tool does the job of five.



Magazine for crimp dies can be carried on a belt

Clearly visible marking on the crimping dies with pictograms

WARNING: This product can expose you to chemicals including Diisononyl Phthalate, which is known to the State of California to cause cancer. For more information go to www.P65Warnings.ca.gov

Product Number	Packaging	↕ Inch mm			Applications	Capacity mm ²	⚖ lbs			
97 33 01		10 250			Non-insulated open plug-type connectors (plug width 4.8 + 6.3 mm)	0.5 - 6.0	1.33			
		-						Insulated terminals, plug connectors and butt connectors	0.5 - 6.0	-
		-						Insulated and non-insulated end sleeves (ferrules)	0.25 - 0.75 / 1 - 1.5 / 2.5 / 4 / 6	-
97 33 02		10 250			Non-insulated open plug-type connectors (plug width 4.8 + 6.3 mm)	0.5 - 6.0	1.92			
		-						Insulated terminals, plug connectors and butt connectors	0.5 - 6.0	-
		-						Insulated and non-insulated end sleeves (ferrules)	0.25 - 0.75 / 1 - 1.5 / 2.5 / 4 / 6	-
		-						Insulated and non-insulated end sleeves (ferrules)	10 / 16 / 25	-
		-						Non-insulated crimp terminals, tube and compression cable lugs in accordance with DIN 46234 and DIN 46235 and non-insulated crimp, butt and press connectors in accordance with DIN 46341 and DIN 46267	0.5 - 10.0	-

Crimp System Pliers

for exchangeable crimping dies

97
43

- > just one tool for almost 1,000 crimping applications
- > parallel crimping die movement
- > repetitive, high crimping quality due to precision dies and integral lock (self-releasing mechanism)
- > crimping pressure has been set precisely (calibrated) in the factory
- > optimum transmission of force due to lever action for fatigue-reduced operation
- > comfortable handle design
- > different locators for precise positioning of the connectors
- > additional crimp dies available upon request
- > chrome vanadium electric steel in special quality; oil-hardened



97 43 200 with crimping dies 97 49 06 for insulated terminals, plug connectors and butt connectors



97 43 200 with crimping dies 97 49 09 for ferrules (end sleeves)

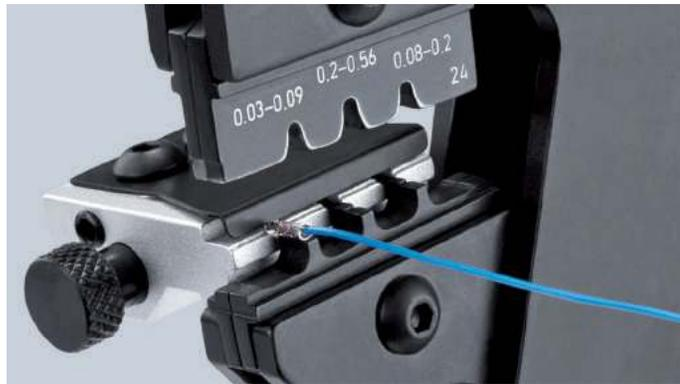

97 43 400 Crimp System Pliers with crimp dies 97 49 24 and locator 97 49 93 for D-Sub plugs



97 43 200
MM



97 43 200 A
MM

97 43 200

In a plastic case; foam insert with recesses for crimping dies and locators; with service tool (hexagonal key), screws and nuts; without crimping dies

97 43 200 A

Pliers without crimping dies, without case

97 43 05

With attached crimping dies for non-insulated open plug-type connectors (4.8 and 6.3 mm connector width)

97 43 06

With attached crimping dies for insulated terminals and plug connectors

WARNING: This product can expose you to chemicals including Diisononyl Phthalate, which is known to the State of California to cause cancer. For more information go to www.P65Warnings.ca.gov

Product Number	Packaging	↔ Inch mm			Pliers	Handles	Applications	Capacity mm ²	Number of crimping positions	⚖ lbs
97 43 05		8 200			burnished	multi-component grips	Crimp System Pliers for non-insulated open plug-type connectors (4.8 and 6.3 mm connector width)	0.5 - 6.0	3	1.33
97 43 06		8 200			burnished	multi-component grips	Crimp System Pliers for insulated terminals and plug connectors	0.5 - 6.0	3	1.35
97 43 200		8 200	-		burnished	multi-component grips	See crimp die profile table	-	-	1.25
97 43 200 A		8 200	-		burnished	multi-component grips	See crimp die profile table	-	-	1.26

Crimping Dies

for Crimp System Pliers

(1,000 special crimping dies upon request)

97
49

Product Number	Packaging		Applications	Cable type	Capacity mm ²	Capacity SW mm Inch mm	Sleeves Ø Inch Ø mm	Number of crimping positions	 lbs
97 49 04			Non-insulated open plug-type connectors (plug width 2.8 + 4.8 mm)	-	0.1 - 2.5	-	-	4	0.09
97 49 05			Non-insulated open plug-type connectors (plug width 4.8 + 6.3 mm)	-	0.5 - 6.0	-	-	3	0.10
97 49 06			Insulated terminals, plug connectors + butt connectors	-	0.5 - 6.0	-	-	3	0.10
97 49 08			Insulated and non-insulated ferrules (end sleeves)	-	0.25 - 6.0	-	-	5	0.11
97 49 09			Insulated and non-insulated ferrules (end sleeves)	-	10 / 16 / 25	-	-	3	0.11
97 49 15			Lug connectors and non-insulated open plug-type connectors (plug width 6.3 mm)	-	1.25-2.5 + 3.0-6.0	-	-	2 + 1	0.12
97 49 16			Insulated terminals + cable connectors	-	10.0 - 16.0	-	-	2	0.10
97 49 18			Twin ferrules (end sleeves) for two flexible conductors	-	2x6 / 2x10 / 2x16	-	-	3	0.11
97 49 19			Insulated and non-insulated ferrules (end sleeves)	-	35 - 50	-	-	2	0.10
97 49 20			F-connectors for TV and satellite connections	-	-	9/32; 21/64; 5/16 7.0; 8.4; 8.1	19/64; 3/8; 3/8 7.7; 9.5; 9.5	3	0.11
97 49 23			Non-insulated terminals + cable connections	-	16 + 25	-	-	2	0.10
97 49 24			D Sub; HD 20; HDE plug	-	0.03 - 0.56	-	-	3	0.09
97 49 30			Non-insulated crimp connectors in accordance with DIN 46267	-	1.5 - 4.0	-	-	3	0.08
97 49 35			Spark plug connectors and distributors	-	1	-	-	5	0.12
97 49 40			Coax connectors RG 58, 59, 62, 71, 223	RG 58, 59, 62, 71, 223	--	7/32; 1/4; 1/16 5.4; 6.48; 1.72	1/4; 19/64; 5/64 6.4; 7.6; 2.1	3	0.13
97 49 44			Rolled contacts	-	0.14 - 1.5	-	-	3	0.10

Crimping Dies

for Crimp System Pliers

(1,000 special crimping dies upon request)

97
49

Product Number	Packaging		Applications	Cable type	Capacity mm ²	Capacity SW mm Inch mm	Sleeves Ø Inch Ø mm	Number of crimping positions	⚖ lbs
97 49 50			 Coax connectors/ car phone RG 58, 74, 188, 316	RG 58, 174, 188, 316	-	1/8; 11/64; 7/32; 1/16; 3/64; 1/32 3.25; 4.52; 5.4; 1.72; 1.07; 0.72	5/32; 7/32; 1/4; 5/64; 3/64; 1/32 3.9; 5.4; 6.4; 2.1; 1.3; 0.95	6	0.11
97 49 54			 Modular plugs	-	0.5 - 2.5	-	-	4	0.11
97 49 60			 Turned contacts (HTS + Harting)	-	0.14 - 4.0	-	-	4	0.12
97 49 62			 Solar connectors (Huber + Suhner)	-	2.5 + 4.0	-	-	3	0.09
97 49 64			 ABS connectors in motor vehicles	-	1.0 - 6.0	-	-	2	0.11
97 49 69 1			 Solar cable connectors gesis® solar PST 40 (Wieland)	-	1.5 - 2.5	-	-	2	0.10
97 49 69 2			 Solar cable connectors gesis® solar PST 40 (Wieland)	-	4.0 - 10.0	-	-	3	0.10
97 49 70			 Western plugs	-	4,6,8-poles RJ 10 / 11 / 12 / 45	-	-	3	0.11
97 49 74			 Unshielded plugs	-	4,6,8-poles RJ 10 / 11 / 12 / 45	-	-	3	0.10
97 49 76			 Shielded Stewart plugs	-	-	-	-	2	0.11
97 49 81			 Fiber optic connectors, e.g. Harting	-	-	1/8; 3/16; 1/4 3.0; 4.95; 6.5	9/64; 15/64; 19/64 3.5; 6.0; 7.5	3	0.12
97 49 82			 Fiber optic connectors, e.g. Telegärtner	-	-	1/8; 9/64; 11/64 3.25; 3.65; 4.52	9/64; 5/32; 7/32 3.6; 4.0; 5.4	3	0.11
97 49 83			 Fiber optic connectors, e.g. FSMA-;ST-; SC- + STSC-/K-connectors	-	-	9/64; 11/64; 13/64 3.65; 4.2; 5.0	11/64; 7/32; 15/64 4.3; 5.4; 6.0	3	0.11
97 49 84			 Fiber optic connectors, e.g. Huber/Suhner	-	-	5/32; 11/64; 3/16 3.8; 4.3; 4.95	11/16; 13/64; 15/64 4.5; 5.2; 6.0	3	0.11
97 49 87			 Fiber optic connectors, e.g. FSMA-;ST- and MIC-connectors	-	-	11/32 8.7	3/8 9.5	1	0.10
97 49 90	Locator for 97 49 60 (HTS+Harting)								
97 49 93	Locator for 97 49 24 (D-Sub-plugs)								
97 49 94	Locator for 97 49 04								
97 49 95	Locator for 97 49 05								

Special profiles available upon request

Locators

for crimping pliers and profiles

97

97 59 65 2

Locator that is universally adjustable (in length and diameter) for the repeatable exact alignment of turned contacts in crimping pliers; can be set to all commercially available turned contacts in the four-mandrel crimping pliers' capacity range.



97 59 65 2

Locator 97 59 65 2 for four-mandrel crimping pliers, adjustable in length and diameter for various plugs

Product Number	Packaging	Applications	⚖️ lbs
97 49 65 1		Locator for 97 49 65 (solar connectors MC 3)	0.19
97 49 66 1		Locator for 97 49 66 (solar connectors MC 4)	0.16
97 49 68 1		Locator for 97 49 68 (solar connectors Solarlok)	0.16
97 59 65 2		Universal Locator for 97 52 65 / 97 52 65 DG	0.35

Crimping Pliers

with side cutter for Scotchlok™ connectors

97
50

- > for crimping plastic-insulated telecommunication or signal cables using the U-contact principle in single Scotchlok connectors
- > no stripping necessary, U-shaped elements make the connection
- > induction hardened cutting edges
- > includes opening spring for easy repetitive work
- > vanadium electric steel; forged, oil-hardened



97 50 01

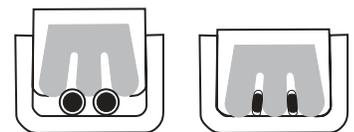

Before

After

Scotchlok™ is a registered trademark for 3M

Product Number	Packaging	↔ Inch mm	Type of Connector	Head	Handles	Applications	Capacity Ø Inch Ø mm	⚖️ lbs
97 50 01		6 1/8 155		MM	polished	plastic coated	Scotchlok single connector 1/64 - 3/64 0.4 - 1.1	0.31

- > professional tool for cutting and stripping unshielded ribbon telephone cables
- > for crimping 6- and 8-pole Western plugs type RJ 11/12 (3/8" / 9.65 mm width) and type RJ 45 (15/32" / 11.68 mm width)
- > exact crimping process due to parallel crimping
- > repetitive, high crimping quality due to integral lock (self-releasing mechanism)
- > length cutter and dismantling knife for ribbon cables 1/4" and 1/2" (6 and 12 mm) length
- > additional stripping device for round cables
- > chrome vanadium electric steel in special quality; oil-hardened
- > 97 51 12 is for crimping 4-, 6- and 8-pole Western plugs type RJ 10 (7.65 mm width), type RJ 11/12 (9.65 mm width) and type RJ 45 (11.68 mm width)



97 51 10



97 51 12



Product Number	Packaging	↔ Inch mm	Type of Connector	Pliers	Handles	Capacity	Number of crimping positions	⚖ lbs
97 51 10		7 1/2 190		burnished	multi-component grips	RJ 11/12 (6-poles) 3/8" (9.65 mm) RJ 45 (8-poles) 15/32" (11.68 mm)	2	0.67
97 51 12		8 200		burnished	multi-component grips	RJ 10 (4-poles) 7.65 mm RJ 11/12 (6-poles) 3/8" (9.65 mm) RJ 45 (8-poles) 15/32" (11.68 mm)	3	1.18
97 59 06	4 spare blades for 97 51 10							
97 59 12	Spare set of blades for 97 51 12							



KNIPLEX

97 52 36

MADE IN GERMANY

0.5-5.0mm² / AWG 20-10

© 2018

Crimping Pliers

for two-handed operation

97
52

- > for solder-free electrical connections
- > the lever transmission reduces the handforce up to 30% compared with regular crimping pliers
- > repetitive, high crimping quality due to precision dies and integral lock (self-releasing mechanism)
- > crimping pressure has been set precisely (calibrated) in the factory
- > two-handed operation for easy crimping of large conductor diameters
- > easy handling as a result of well-balanced center of gravity, angled head and ergonomically shaped handles
- > chrome vanadium electric steel in special quality; oil-hardened



First step: place the connector into the correct crimping position. Squeeze handles slightly to secure connector inside die



Second step: insert wire into connector and squeeze handles to complete crimp



Third step: handles are long enough for two-handed operation. Handles will release automatically when the crimp is complete



Product Number	↔ Inch mm			Pliers	Handles	Applications	Capacity mm ²	AWG	Number of crimping positions	⚖ lbs
97 52 04	10 250			burnished	non-slip plastic grips	Non-insulated open plug-type connectors (plug width 2.8 + 4.8 mm)	0.1 - 2.5	26 - 14	4	1.24
97 52 05	10 250			burnished	non-slip plastic grips	Non-insulated open plug-type connectors (plug width 4.8 + 6.3 mm)	0.5 - 6.0	22 - 8	3	1.26
97 52 06	10 250			burnished	non-slip plastic grips	Insulated terminals, plug connectors + butt connectors	0.5 - 6.0	22 - 8	3	1.25
97 52 08	10 250			burnished	non-slip plastic grips	Insulated and non-insulated ferrules (end sleeves)	0.25 - 6.0	24 - 8	5	1.25
97 52 09	10 250			burnished	non-slip plastic grips	Insulated and non-insulated ferrules (end sleeves)	10 / 16 / 25	8 / 6 / 4	3	1.26
97 52 10	10 250			burnished	non-slip plastic grips	COAX-, BNC- and TNC-connectors	-	-	3	1.27
97 52 13	10 250			burnished	non-slip plastic grips	Non-insulated crimp terminals, tube and compression cable lugs in accordance with DIN 46234 and DIN 46235 and non-insulated crimp, butt and press connectors in accordance with DIN 46341 and DIN 46267	0.5 - 10.0	22 - 8	4	1.23
97 52 19	10 250			burnished	non-slip plastic grips	Insulated and non-insulated ferrules (end sleeves)	35 - 50	2 and 0 (1/0)	2	1.25
97 52 23	10 250			burnished	non-slip plastic grips	Non-insulated terminals + cable connectors	16 + 25	6 and 4	2	1.25

Crimping Pliers

with short design

97
52

- > repetitive, high crimping quality due to precision dies and integral lock (self-releasing mechanism)
- > crimping pressure has been set precisely (calibrated) in the factory
- > optimum transmission of force due to toggle lever for fatigue-reduced operation
- > 20° angled head, lightweight and compact design
- > chrome vanadium electric steel in special quality; oil-hardened

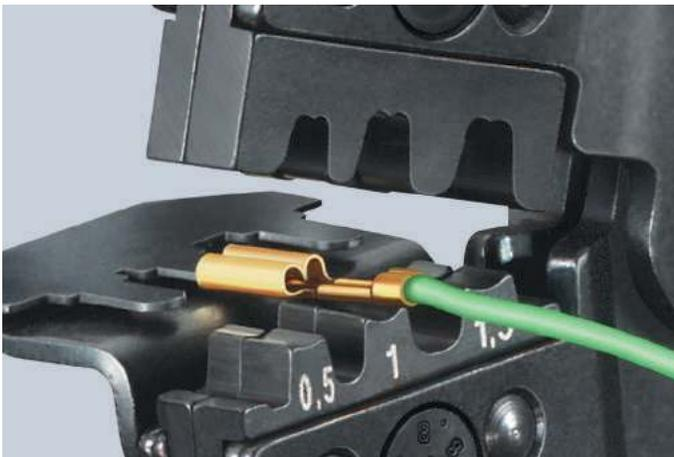

97 52 14



WARNING: This product can expose you to chemicals including Diisononyl Phthalate, which is known to the State of California to cause cancer. For more information go to www.P65Warnings.ca.gov

97 59 14

> Locator for non-insulated open plug-type connectors

Product Number	Packaging	↔ Inch mm		Pliers	Handles	Applications	Capacity mm ²	AWG	Number of crimping positions	⚖ lbs	
97 52 14		7 1/2 195			burnished	multi-component grips	Non-insulated open plug- type connectors (plug width 2.8 + 4.8 mm)	0.10 - 1.5	26 - 16	4	0.85
97 52 20		7 1/2 195			burnished	multi-component grips	COAX-, BNC- and TNC-connectors RG 58/59/62/71/223	-	-	3	0.84

97 59 14 Locator for 97 52 14 short design

- > repetitive, high crimping quality due to precision dies and integral lock (self-releasing mechanism)
- > crimping pressure has been set precisely (calibrated) in the factory
- > optimum transmission of force due to toggle lever for fatigue-reduced operation
- > good handling due to favorable handle position, low weight, short design and ergonomically shaped handles
- > chrome vanadium electric steel in special quality; oil-hardened



97 52 37

WARNING: This product can expose you to chemicals including Diisononyl Phthalate, which is known to the State of California to cause cancer. For more information go to www.P65Warnings.ca.gov



97 52 30
 



97 52 33
 



97 52 34
 



97 52 36
 



97 52 38
 

Product Number	↔ Inch mm			Pliers	Handles	Applications	Capacity mm ²	AWG	Number of crimping positions	⚖ lbs
97 52 30	8 3/4 220			burnished	multi-component grips	Non-insulated crimp connectors in accordance with DIN 46267	1.5 - 4.0	16 - 12	3	1.06
97 52 33	8 3/4 220	 		burnished	multi-component grips	Non-insulated crimp terminals, tube and compression cable lugs in accordance with DIN 46234 and DIN 46235 and non-insulated crimp, butt and press connectors in accordance with DIN 46341 and DIN 46267	0.5 - 10.0	22 - 8	4	1.06
97 52 34	8 3/4 220			burnished	multi-component grips	Non-insulated open plug-type connectors (plug width 2.8 + 4.8 mm)	0.1 - 2.5	26 - 14	4	1.07
97 52 35	8 3/4 220			burnished	multi-component grips	Non-insulated open plug-type connectors (plug width 4.8 + 6.3 mm)	0.5 - 6.0	22 - 10	3	1.08
97 52 36	8 3/4 220	 		burnished	multi-component grips	Insulated terminals, plug connectors + butt connectors	0.5 - 6.0	22 - 10	3	1.08
97 52 37	8 3/4 220			burnished	multi-component grips	Heat shrinkable sleeve connectors	0.5 - 6.0	22 - 10	3	1.05
97 52 38	8 3/4 220	 		burnished	multi-component grips	Insulated and non-insulated ferrules (end sleeves)	0.25 - 6.0	24 - 10	5	1.09
97 52 50	8 3/4 220			burnished	multi-component grips	COAX-, BNC- and TNC-connectors for RG 58/174/188/316	-	-	6	1.10

Four-Mandrel Crimping Pliers for turned contacts

97
52

- > for crimping turned contacts
- > four-mandrel crimping for top-quality crimping connections
- > mandrel gauge to check the basic setting
- > repetitive, high crimping quality due to integral lock (self-releasing mechanism)
- > optimum transmission of force due to highly effective lever action for fatigue-reduced operation
- > high operation comfort due to ergonomic shape
- > chrome vanadium electric steel in special quality; oil-hardened

97 52 63 DG

Crimping capacity can be adjusted in increments of .0004" (0.01 mm); with digital display of the preset crimping capacities; adjustment in mm, inches or comparable selection positions according to MIL; packaged in a plastic case with foam insert and locator for holding the contacts

97 52 64

Pressure adjustment depending on the conductor's diameter by means of adjusting wheel in 4 different positions; locator for positioning the contacts

97 52 65

Fine adjustment of pressure depending on the conductor's diameter by means of adjusting wheel; locator for positioning the contacts; with table for calculating the settings; pliers in a plastic case with foam insert

97 52 65 DG

Crimping capacity can be adjusted in increments of .0004" (0.01 mm); with digital display of the preset crimping capacities; adjustment in mm, inches or comparable selection positions according to MIL; with table for calculating the settings; packaged in a plastic case with foam insert and locator for holding the contacts

Turned contacts are used for particularly demanding plug-type connections, e.g. in medical industry and aviation. Extremely reliable crimping connections can be achieved only with pliers that work with absolute precision and maintain the required crimping depth in the 1/100 mm range. KNIPEX has all of the tools you need to get these jobs done.



97 59 65 2
Universal Locator



97 52 63 DG

PATENTED ✖ M



97 52 64

✖ M



97 52 65

PATENTED ✖ M



97 52 65 DG

PATENTED ✖ M





Standard locator



Multifunctional digital indication, adjustment in mm, inches or comparable selection positions according to MIL

WARNING: This product can expose you to chemicals including Diisononyl Phthalate, which is known to the State of California to cause cancer. For more information go to www.P65Warnings.ca.gov

Product Number	Packaging	↔ Inch mm			Pliers	Handles	Applications	Capacity mm ²	AWG	⚖️ lbs
97 52 63 DG	X	7 1/2 195			chrome plated	multi-component grips	Turned contacts	0.08 - 2.5	28 - 13	1.89
97 52 64	X	7 1/4 180			chrome plated	multi-component grips	Turned contacts	0.08 - 2.5	28 - 13	0.94
97 52 65	X	9 1/4 235			chrome plated	multi-component grips	Turned contacts (Harting; Ilme; Phoenix; Amphenol; Walther; HTS; Contact; Weidmüller)	0.14 - 6.0	25 - 10	1.5
97 52 65 DG	X	10 250			chrome plated	multi-component grips	Turned contacts (Harting; Ilme; Phoenix; Amphenol; Walther; HTS; Contact; Weidmüller)	0.14 - 6.0	25 - 10	2.8
97 59 65 2	Universal Locator for 97 52 65 / 97 52 65 DG									

Self-Adjusting Crimping Pliers

with side-loading mechanism for ferrules (end sleeves)

97
53

Narrow handle width and improved ergonomics

- > for crimping ferrules (end sleeves) according to DIN 46228 parts 1 + 4
- > self-adjustment to the size of ferrules (end sleeves) required
- > repetitive, high crimping quality due to integral lock (self-releasing mechanism)
- > crimping pressure has been set precisely (calibrated) in the factory
- > optimum transmission of force due to toggle lever for fatigue-reduced operation
- > high operation comfort due to hand shape and low weight
- > chrome vanadium electric steel in special quality; oil-hardened

97 53 04

Square compression for ferrules (end sleeves) up to 6 AWG; square compression for ideal contact surfaces in the clamp connection; particularly suitable for all twin ferrules (end sleeves) up to 2 x 6 mm² or 2 x AWG 8

97 53 14

Expanded capacity of hexagonal crimping up to 1 AWG; hexagonal compression for confined connection dimensions; particularly suitable for all twin ferrules (end sleeves) up to 2 x 4 mm² or 2 x AWG 10



97 53 04



97 53 14



Crimping capacity can be switched over simply from 8 AWG (10 mm²) to 6 AWG (16 mm²)

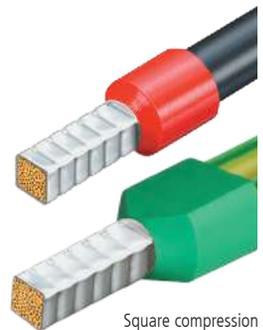

Square compression

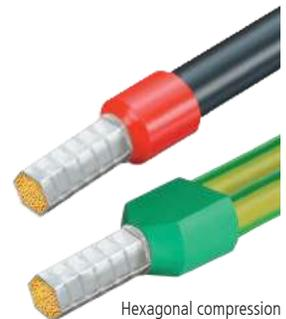

Hexagonal compression

The small crimping pliers for ferrules (end sleeves) with two major advantages for the user:

- > Automatic adjustment to the end sleeves, making work easier for the professional and offers reliable and fast crimping
- > Expanded range of applications

WARNING: This product can expose you to chemicals including Diisononyl Phthalate, which is known to the State of California to cause cancer. For more information go to www.P65Warnings.ca.gov

Product Number	Packaging	↔ Inch mm			Pliers	Handles	Applications	Capacity mm ²	AWG	Number of crimping positions	⚖ lbs	
97 53 04		7 1/4 180					burnished multi-component grips	Ferrules (end sleeves)	0.08 - 10 and 16	28 - 8 and 6	1	0.94
97 53 14		7 1/4 180					burnished multi-component grips	Ferrules (end sleeves)	0.08 - 10.0	28 - 8	1	0.90

KNIPEX Twistor16

Self-adjusting crimping pliers for end sleeves (ferrules) with rotating crimp head

97
53

Crimp head can be freely rotated 360°, with 8 locking positions
Square crimp profile, high capacity range of 26 to 6 AWG (0.14 to 16 mm²)

End sleeves (ferrules) can be crimped from almost any working position

- > crimping pliers adjust automatically to different diameters
- > crimp opening is accessible from both sides, extra-long end sleeves can be fed in
- > crimping of twin end sleeves (ferrules) up to 2 x 6 mm² possible
- > repetitive, high crimping quality due to integral lock (self-releasing mechanism)
- > light and handy tool, manual force reinforced by toggle lever mechanism
- > chrome vanadium electric steel in special quality; oil-hardened



97 53 18

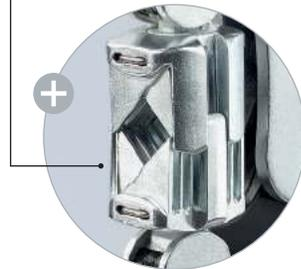

Crimp head can be rotated 360°



Crimp head can be rotated 360° for optimal accessibility, even in confined spaces



Twin end sleeves (ferrules) up to 2 x 6 mm² can be crimped without adjustment

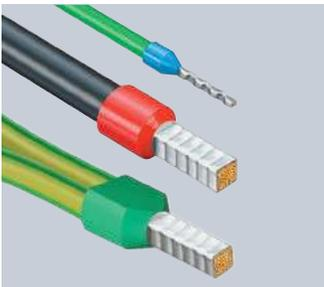

Crimp end sleeves (ferrules) fully automatically within the capacity range of 26 to 6 AWG (0.14 to 16 mm)



Uniquely flexible: connectors can be inserted in the rotatable crimp head from almost any position



Product Number	Packaging	↔ Inch mm	Capacity mm ²	AWG	Number of crimping positions	⚖️ lbs
97 53 18		8 200	0.14 - 16	26 - 6	1	1.05

Self-adjusting Crimping Pliers

with front loading mechanism for ferrules (end sleeves)

97
53

- > for crimping ferrules (end sleeves) according to DIN 46228 parts 1 + 4
- > self-adjusting adaptation to the desired wire ferrule (end sleeves) size: no crimping faults caused by using the wrong die
- > front-loading of the ferrules (end sleeves) into the tool
- > repetitive, high crimping quality due to integral lock (self-releasing mechanism)
- > crimping pressure has been set precisely (calibrated) in the factory
- > optimum transmission of force due to toggle lever for fatigue-reduced operation
- > high operation comfort due to handle shape and low weight
- > chrome vanadium electric steel in special quality; oil-hardened

97 53 08

Crimping from 28 - 8 AWG (0.08 - 10.0 mm²) in one profile; wire ferrules (end sleeves) up to 14 AWG (2.5 mm²) can also be loaded parallel from the side; particularly suitable for all twin ferrules (end sleeves) up to 2 x 4 mm² or 2 x AWG 10

97 53 09

Crimping from 28 - 8 and 6 AWG (0.08 - 10.0 and 16.0 mm²) in one profile; with selector lever for setting the crimping area either to 28 - 8 and 6 AWG (0.08 - 10 mm² or 16 mm²); particularly suitable for all twin ferrules (end sleeves) up to 2 x 6 mm² or 2 x AWG 8



97 53 08



97 53 09



Square crimping



Front-loading of ferrules (end sleeves) e.g. in switchboards



97 53 08: Lateral loading of ferrules (end sleeves) up to 14 AWG (2.5 mm²) parallel from the side e.g. in confined areas

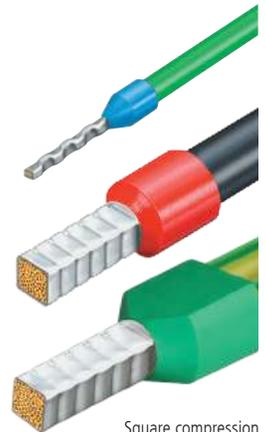

Square compression

The crimping pliers for wire ferrules (end sleeves) with three great advantages for the user:

- > Automatic self-adjustment to the wire ferrules (end sleeves): This allowing the professional to work with less strain and enables secure, reliable and quick crimping
- > Range of applications for large cross-sections: crimping 28 - 8 and 6 AWG (0.08 to 10.0 + 16.0 mm²)
- > Front-loading: very helpful under difficult working conditions in confined spaces

WARNING: This product can expose you to chemicals including Diisononyl Phthalate, which is known to the State of California to cause cancer. For more information go to www.P65Warnings.ca.gov

Product Number	Packaging	↔ Inch mm			Pliers	Handles	Applications	Capacity mm ²	AWG	Number of crimping positions	⚖ lbs
97 53 08	X	7 1/2 190			burnished	multi-component grips	Ferrules (end sleeves)	0.08 - 10	28 - 8	1	1.05
97 53 09		7 1/2 190			burnished	multi-component grips	Ferrules (end sleeves)	0.08 - 10 and 16	28 - 8 and 6	1	1.07

Crimping Pliers

for wire ferrules (end sleeves)

97
6

- > for crimping wire ferrules (end sleeves) according to DIN 46228 parts 1 and 4 in an area of application from 24 - 14 AWG (0.25 up to 2.5 mm²)
- > crimping in marked trapezoidal dies for tight connections between the sleeve and the conductor
- > vanadium electric steel; forged, oil-hardened



97 62 145 A



97 68 145 A



Product Number	Packaging	↔ Inch mm			Head	Handles	Capacity mm ²	AWG	Number of crimping positions	⚖️ lbs
97 61 145 A		5 3/4 145			polished	plastic coated	0.25 - 2.5	24 - 14	4	0.31
97 61 145 F		5 3/4 145			polished	plastic coated	0.25 - 2.5	24 - 14	4	0.31
97 62 145 A		5 3/4 145			polished	multi-component grips	0.25 - 2.5	24 - 14	4	0.38
97 68 145 A		5 3/4 145			polished	insulated, multi-component grips, VDE-tested	0.25 - 2.5	24 - 14	4	0.41

Crimping Pliers

for wire ferrules (end sleeves)

97
7

Easy crimping due to optimized transmission ratio
Light and slim design

- > for crimping wire ferrules (end sleeves) according to DIN 46228 parts 1 and 4 from 5 to 23 AWG (0.25 to 16 mm²)
- > crimping in marked half-round dies for secure connections between the sleeve and the conductor
- > high-grade special tool steel; forged, oil-hardened



97 71 180



97 72 180



0.75 mm²

6 mm²

16 mm²

Product Number	Packaging	↔ Inch mm			Head	Handles	Applications	Capacity mm ²	AWG	Number of crimping positions	⚖️ lbs
97 71 180		7 1/4 180			polished	plastic coated	ferrules (end sleeves)	0.25 - 16.0	24 - 6	9	0.45
97 72 180		7 1/4 180			polished	multi-component grips	ferrules (end sleeves)	0.25 - 16.0	24 - 6	9	0.53

Crimping Pliers

with front loading mechanism for wire ferrules (end sleeves)

97
8

- > for crimping ferrules (end sleeves) according to DIN 46228 parts 1 + 4 in the range 0.5 to 6 mm²
- > ideal for work in confined areas, e.g. in narrow and deep switch boxes
- > special tool steel; forged, oil-hardened

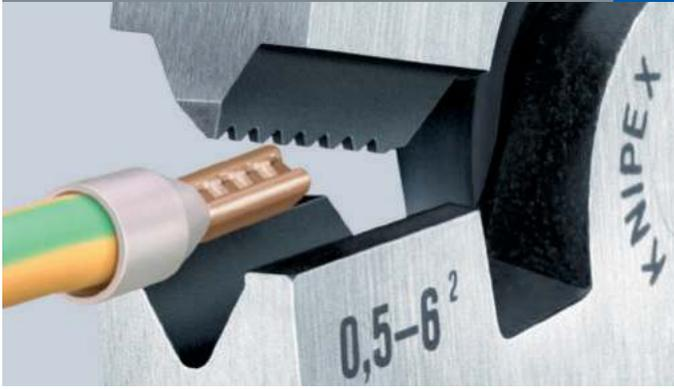

97 81 180



Product Number	Packaging	↔ Inch mm			Head	Handles	Applications	Capacity mm ²	AWG	Number of crimping positions	⚖ lbs
97 81 180		7 1/4 180			polished	plastic coated	ferrules (end sleeves)	0.5 - 6.0	24 - 0	1	0.45



Crimp Assortments

for ferrules (end sleeves)

97
90

- > in a TANOS MINI-systainer® (solid plastic box)
- > T-Loc fastener for one-hand operation: open or close the systainer® with one turn and connect to a second systainer®
- > opening when connected: fast and simple access to content without disconnecting
- > two stackable plastic inserts with 6 trays each for connectors
- > with an assortment of ferrules (end sleeves) with collar

97 90 05

With Crimping Pliers for ferrules 97 71 180

97 90 06

With Crimping Pliers for ferrules 97 71 180

97 90 09

With Self-Adjusting Crimping Pliers for ferrules (end sleeves) 97 53 04

97 90 10

With Self-Adjusting Insulation Strippers 12 40 200; with Self-Adjusting Crimping Pliers for ferrules (end sleeves) 97 53 04

97 90 12

With Self-Adjusting Insulation Strippers 12 40 200; with Self-Adjusting Crimping Pliers for ferrules (end sleeves) 97 53 08

97 90 23

With Crimping Pliers "PreciForce®" for ferrules (end sleeves) 97 52 38

97 90 24

With Self-Adapting Universal Insulation Stripper "Multistrip 10" 12 42 195; with Self-Adjusting Crimping Pliers for ferrules (end sleeves) 97 53 08



97 90 05



97 90 06



97 90 09



97 90 10



97 90 12



97 90 23



97 90 24

Product Number	Packaging	Pliers		Quantity						Units	lbs
				200 x mm ²	150 x mm ²	100 x mm ²	75 x mm ²	50 x mm ²	40 x mm ²		
97 90 05	X	Crimping assortment for ferrules (end sleeves)		0.5 / 0.75 / 1 / 1.5 / 2.5	4 / 6	-	-	10 / 16	-	1	2.05
97 90 06	X	97 71 180 Crimping Pliers for ferrules (end sleeves)		0.5 / 0.75 / 1 / 1.5	2.5	-	4 / 6	10	16	1	2.21
97 90 09	X	97 53 04 Self-Adjusting Crimping Pliers for ferrules (end sleeves)		0.5 / 0.75 / 1 / 1.5 / 2.5	-	4 / 6	-	10	-	1	3.13
97 90 10	X	97 53 04 Self-Adjusting Insulation Strippers 12 40 200 Self-Adjusting Crimping Pliers for ferrules (end sleeves)		0.5 / 0.75 / 1 / 1.5 / 2.5	-	4 / 6	-	10	-	1	2.98
97 90 12	X	97 53 08 Self-Adjusting Insulation Strippers 12 40 200 Self-Adjusting Crimping Pliers for ferrules (end sleeves)		0.5 / 0.75 / 1 / 1.5 / 2.5	-	4 / 6	-	10	-	1	3.15
97 90 23	X	97 52 38 Crimping Pliers "PreciForce®" for ferrules (end sleeves)		0.5 / 0.75 / 1 / 1.5 / 2.5	-	4 / 6	-	-	-	1	2.70
97 90 24	X	97 53 08 Self-Adapting Universal Insulation Stripper "Multistrip 10" 12 42 195 Self-Adjusting Crimping Pliers for ferrules (end sleeves)		0.5 / 0.75 / 1 / 1.5 / 2.5	-	4 / 6	-	10	-	1	2.97

- > with tools for photovoltaics
- > without crimp dies – for individual equipment – please order separately (see ref. 97 49 ..)
- > with service tool (Allen key) for changing crimp dies
- > shock-resistant plastic case
- > foam insert with recesses for tools, crimp dies and locators
- > ext. dimension (W x H x D):
13 37/64 x 3 5/32 x 11" (345 x 80 x 280 mm)



97 91 01

Product Number	Packaging			Description	Units	⚖ lbs
97 91 01	X	-	-	Tool case for photovoltaics	-	4.33
		MM	12 12 11	Precision Insulation Stripper, with shaped blades	1	-
		⚡ 1000V ⚠ ⚡ ⚠ ⚠	95 16 165	Cable Shears	1	-
		MM	97 43 200	Crimp System Pliers, for exchangeable crimp profiles	1	-
97 49 62				Crimp Profile for solar cable connectors (Huber + Suhner)		
97 49 63				Crimp Profile for solar cable connectors (Huber + Suhner)		
97 49 65				Crimp Profile for solar cable connectors MC 3 (Multi-Contact)		
97 49 65 1				Locator for 97 49 65 (solar connectors MC 3)		
97 49 66				Crimp Profile for solar cable connectors MC 4 (Multi-Contact)		
97 49 66 1				Locator for 97 49 66 (solar connectors MC 4)		
97 49 67				Crimp Profile for solar cable connectors SunCon (Hirschmann)		
97 49 68				Crimp Profile for turned solar cable connectors (Tyco)		
97 49 68 1				Locator for 97 49 68 (solar connectors Solarlok)		
97 49 69 1				Crimp Profile for solar cable connectors gesis® solar PST 40 (Wieland)		
97 49 69 2				Crimp Profile for solar cable connectors gesis® solar PST 40 (Wieland)		

10 Profiles, 2 crosses, 1 key
For all common locking systems

- > multifunctional key for the actuation of locking systems from the areas of facilities engineering (heating and sanitation, air conditioning, electro technology), gas and water supply and shut-off systems
- > 8-arm version: 2, 4-way wheel wrenches connected in a space-saving way using magnets
- > reversible bit: slot 3/64 x 9/32" (1.0 x 7 mm) and PH2 cross slot
- > key and reversible bit joined by stable stainless steel wire
- > quality surface coating
- > lightweight-optimized zinc die-cast design

TwinKey®



⚠ WARNING: This product can expose you to chemicals including Nickel, which is known to the State of California to cause cancer. For more information go to www.P65Warnings.ca.gov



Product Number	Packaging	↔ Inch mm	⊖ Inch mm	⊖ Inch mm	⊖ Inch mm	⊖ Inch mm	⊖ Inch mm	⊖ Inch mm	⚖ lbs
00 11 01	X	3 3/4 95	13/64, 15/64 - 9/32, 5/16 - 23/64, 25/64 - 7/16 5/6 - 7/8 - 9/10 - 11	9/32 - 5/16, 23/64 - 25/64, 7/16 - 15/32 7 - 8 / 9 - 10 / 11 - 12	1/8 - 13/64 3 - 5	15/64 6	15/64 - 23/64 6 - 9	0.33	

Control Cabinet Keys

for all standard cabinets and shut-off systems

00
11

- > for control cabinets and shut-off systems in the supply of gas, water and electricity
- > for technical installations in buildings, e.g. air conditioning and ventilation systems, shut-off valves, main switchboards, etc.
- > with bit insert: slot 3/64 x 9/32" (1.0 x 7 mm) and cross recess PH2
- > with adapter for 1/4" bits on securing chain
- > additional bit adapter for 1/4" bits in one arm
- > zinc die-casting



00 11 02
Short execution, total length 1 3/4" (44 mm)

00 11 03
Long execution, total length 3" (76 mm);
additional square of 13/64" (5 mm)

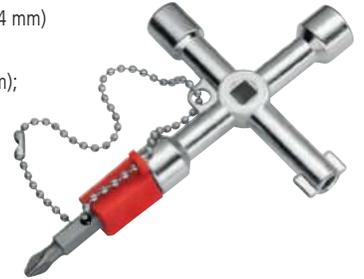

00 11 03

Product Number	Packaging	↔ Inch mm	□ Inch mm	□ Inch mm	□ Inch mm	⚖ lbs
00 11 02	X	1 3/4 44	15/64, 5/16 6 / 8	23/64 9	1/8 - 13/64 3 - 5	0.11
00 11 03	X	3 76	13/64, 15/64, 5/16 5 / 6 / 8	23/64 9	1/8 - 13/64 3 - 5	0.17

Profi-Key

for all standard shut-off systems

00
11

- > key for heating, air conditioning, sanitary and building engineering, e.g. for door and window handles or for air bleeding heaters
- > with bit insert: slot 3/64 x 9/32" (1.0 x 7 mm) and cross recess PH2
- > with adapter for 1/4" bits on securing chain
- > additional bit adapter for 1/4" bits in one arm
- > total length: 3 1/2" (90 mm)
- > zinc die-casting



00 11 04

Product Number	Packaging	↔ Inch mm	□ Inch mm	□ Inch mm	□ Inch mm	⚖ lbs
00 11 04	X	3 1/2 90	13/64, 9/32, 5/16 5 / 7 / 8	23/64 - 25/64 9 - 10	15/64, 9/32, 5/16, 23/64 6 / 7 / 8 / 9	0.16

Universal Key

for all standard cabinets and shut-off systems

00
11

- > for locking systems in electrical engineering, the supply of gas and water, air conditioning and ventilation systems, industry, technical installations in buildings, etc.
- > 9 different die-cast zinc key profiles in 1 tool
- > with detachable chain and snap hook
- > total length: 3 1/2" (90 mm)
- > zinc die-casting



00 11 06



Product Number	Packaging	↔ Inch mm	⊖ Inch mm	⊖ Inch mm	⊖ Inch mm	⊖ Inch mm	⊖ Inch mm	⚖ lbs
00 11 06	X	3 1/2 90	13/64, 15/64, 9/32 - 5/16, 23/64 - 25/64 5 / 6 / 7 - 8 / 9 - 10	9/32, 5/16 - 23/64, 25/64 - 7/16 7 / 8-9 / 10 - 11	1/8 - 13/64 3 - 5	15/64 6		0.47

Universal Key "Construction"

for all standard cabinets and shut-off systems

00
11

- > for locking systems in electrical engineering, the supply of gas and water, air conditioning and ventilation systems, industry, technical installations in buildings, etc.
- > 9 different die-cast zinc key profiles in 1 tool
- > "construction" version with plug-in, magnetically held support: catch for locks with profile cylinder hole and male square in steps
- > with bit adapter for 1/4" bits with magnet
- > with detachable chain and snap hook
- > total length: 6 1/4" (160 mm)
- > zinc die-casting



00 11 06 V01

Product Number	Packaging	↔ Inch mm	⊖ Inch mm	⊖ Inch mm	⊖ Inch mm	⊖ Inch mm	⊖ Inch mm	⚖ lbs
00 11 06 V01	X	6 1/4 160	13/64, 15/64, 9/32 - 5/16, 23/64 - 25/64 5 / 6 / 7 - 8 / 9 - 10	9/32, 5/16 - 23/64, 25/64 - 7/16 7 / 8 - 9 / 10 - 11	1/8 - 13/64 3 - 5	15/64 6	15/64, 9/32, 5/16, 23/64, 25/64 6 / 7 / 8 / 9 / 10	0.56

Magnetic LED Lamp

00
11

Strong. Bright. Compact.

- > for illuminating dark working areas
- > attachment to tool by means of strong magnets
- > very compact dimensions
- > approx. 24 hours of lighting, with 2 replaceable button cells (CR1220)
- > snap hook fastening
- > impact-resistant plastic housing



00 11 V50

WARNING: This product can expose you to chemicals including Nickel, which is known to the State of California to cause cancer. For more information go to www.P65Warnings.ca.gov

Product Number	Packaging	lbs
00 11 V50	X	0.02

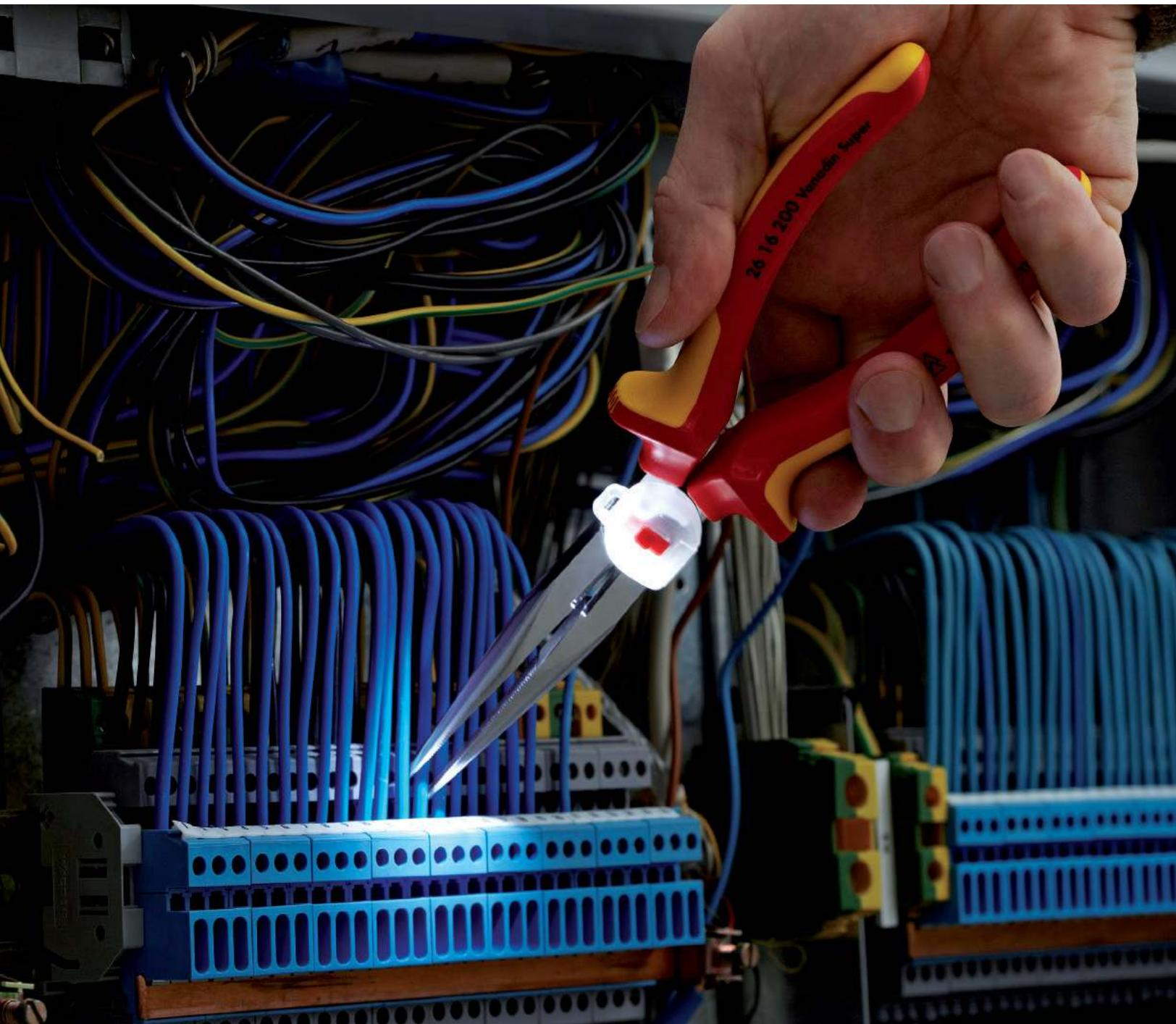

Tool Roll

11 parts

00
19

- > for telecommunications and electrical engineers
- > tool roll made of hard-wearing polyester fabric
- > with sturdy, adjustable snap closure
- > contains 8 pliers and 3 screwdrivers
- > pliers with chrome plated heads and two-color multi-component grips
- > screwdrivers VDE tested according to DIN EN/IEC 60900 1000V



00 19 41

Product Number	Packaging		Set contents	Units	lbs
00 19 41		-	Tool Roll 11 parts	-	3.57
			03 05 160	Combination Pliers	1
			11 05 160	Insulation Stripper	1
			25 05 160	Snipe Nose Side Cutting Pliers, (Radio Pliers)	1
			30 15 160	Long Nose Pliers	1
			30 35 160		1
			31 15 160	Flat Nose Pliers, (Needle Nose Pliers)	1
			67 05 140	High Leverage End Cutting Nippers	1
			70 05 140	Diagonal Cutter	1
			98 20 25	Screwdrivers for slotted screws	1
			98 20 40		1
			98 24 01	Screwdriver for cross recessed screws, Phillips®	1

Family Sets

5-piece

00
19

- > tool roll made of hard-wearing polyester fabric
- > with hook and loop fastener



00 19 55 S4



00 19 55 S5

Product Number	Packaging		Set contents	Units	lbs
00 19 55 S4		-	Set of Pliers Wrenches	-	4.54
			86 03 125	Pliers Wrench, Pliers and Wrench in a single tool	1
			86 03 150		1
			86 03 180		1
			86 03 250		1
			86 03 300		1
00 19 55 S5		-	Set of Cobra Water Pump Pliers	-	3.45
			87 01 125	The original push-button pliers	1
			87 01 150		1
			87 01 180		1
			87 01 250		1
			87 01 300		1

Circlip Pliers Sets

00
19

- > tool roll made of hard-wearing polyester fabric
- > with sturdy, adjustable snap closure

00 19 56

4 common Circlip Pliers for internal and external circlips

00 19 57

4 common Precision Circlip Pliers for highest requirements

00 19 58 V01

8 common Circlip Pliers for internal and external circlips

00 19 58 V02

8 common Precision Circlip Pliers for highest requirements



00 19 56



00 19 57

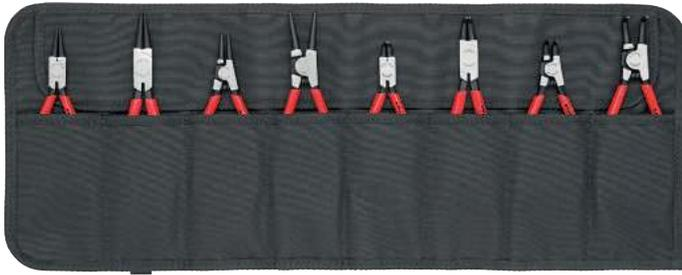

00 19 58 V01



00 19 57



Product Number	Packaging			Set contents	Units	lbs
00 19 56	X	-	Set of Circlip Pliers	-	-	1.58
		☉	44 11 J2	Circlip Pliers, for internal circlips in bore holes	1	-
		☉ ∠90°	44 21 J21		1	-
		☉ MM	46 11 A2	Circlip Pliers, to assemble external circlips on shafts	1	-
		☉ ∠90° MM	46 21 A21		1	-
00 19 57	X	-	Set of Precision Circlip Pliers	-	-	1.62
		☉ ☒	48 11 J1	Precision Circlip Pliers, for internal circlips in bore holes	1	-
		☉ ☒	48 11 J2		1	-
		☉ ☒ MM	49 11 A1	Precision Circlip Pliers, to assemble external circlips on shafts	1	-
		☉ ☒ MM	49 11 A2		1	-
00 19 58 V01	X	-	Set of Circlip Pliers	-	-	1.48
		☉	44 11 J1	Circlip Pliers, for internal circlips in bore holes	1	-
		☉	44 11 J2		1	-
		☉ ∠90°	44 21 J11		1	-
		☉ ∠90°	44 21 J21		1	-
		☉ MM	46 11 A1	Circlip Pliers, to assemble external circlips on shafts	1	-
		☉ MM	46 11 A2		1	-
		☉ ∠90° MM	46 21 A11		1	-
		☉ ∠90° MM	46 21 A21		1	-
00 19 58 V02	X	-	Set of Precision Circlip Pliers	-	-	1.47
		☉ ☒	48 11 J1	Circlip Pliers, for internal circlips in bore holes	1	-
		☉ ☒	48 11 J2		1	-
		☉ ∠90° ☒	48 21 J11		1	-
		☉ ∠90° ☒	48 21 J21		1	-
		☉ ☒ MM	49 11 A1	Circlip Pliers, to assemble external circlips on shafts	1	-
		☉ ☒ MM	49 11 A2		1	-
		☉ ∠90° ☒ MM	49 21 A11		1	-
		☉ ∠90° ☒ MM	49 21 A21		1	-
00 19 56 LE			Empty tool roll			

Belt pouch empty

00
19

- > made of hard-wearing polyester fabric
- > for two pliers up to 6" (150 mm) length
- > with hook and loop fastener
- > with elastic side
- > with practical belt loop



00 19 72 LE

Product Number	Packaging	Width Inch mm	Height Inch mm	Depth Inch mm	⚖️ lbs
00 19 72 LE	X	2 9/16 65	6 7/64 155	1 25	0.17

Tool Pouch empty

00
19

- > made of hard-wearing polyester fabric and leather
- > with pockets for up to 8 tools
- > tool loops made of leather, riveted
- > with snap hook



00 19 73 LE

Product Number	Packaging	Width Inch mm	Height Inch mm	Depth Inch mm	⚖️ lbs
00 19 73 LE	X	6 3/4 170	9 1/4 235	3 75	0.45

Pliers Sets

in a foam tray

00
20

- > packaged in a foam tray for workbenches and tool trolleys
- > clearly organized storage of tools
- > precisely sized recesses for holding the pliers
- > foam insert dimensions (LxWxH):
13 3/16 x 6 1/2 x 1 19/64" (335 x 165 x 33 mm)
- > material: two-color, closed pore foam

- 00 20 01 V02**
6 Circlip Pliers in a foam tray
- 00 20 01 V15**
- 00 20 01 V16**
- 00 20 01 V17**
4 pliers in a foam tray



00 20 01 V02



00 20 01 V15



00 20 01 V17



00 20 01 V16

Product Number	Packaging		Set contents	Units	⚖️ lbs
00 20 01 V02	X	-	Circlip Pliers Set six precision circlip pliers in a foam tray	-	2.02
		🔧	48 11 J1	1	-
		🔧	48 11 J2	1	-
		🔧 90°	48 21 J21	1	-
		🔧	49 11 A1	1	-
		🔧	49 11 A2	1	-
		🔧 90°	49 21 A21	1	-
00 20 01 V15	X	-	Pliers Set "Basic" four pliers in a foam tray	-	2.47
		🔧	03 02 180	1	-
		🔧	26 12 200	1	-
		🔧	74 02 180	1	-
		🔧	87 01 250	1	-
00 20 01 V16	X	-	Pliers Set "Automotive" four pliers in a foam tray	1	1.87
		🔧	08 21 145	1	-
		🔧	74 01 180	1	-
		🔧	28 71 280	1	-
		🔧 45°	28 81 280	1	-
00 20 01 V17	X	-	Pliers Set "Basic" four pliers in a foam tray	-	2.41
		🔧	03 05 180	1	-
		🔧	26 15 200	1	-
		🔧	74 05 180	1	-
		🔧	87 05 250	1	-

Precision Circlip Pliers Sets

00
20

- > contains the most common Precision Circlip Pliers
- > form-fitted inserted and pressed-in tips made of high density spring steel
- > up to 10 times longer service life compared to turned tips
- > internal design for fitting internal circlips in bore holes
- > external design for fitting circlips on shafts

00 20 03 SB

4 parts

00 20 04 SB

8 parts



00 20 03 SB



00 20 04 SB



Product Number	Packaging		Set contents	Units	lbs
00 20 03 SB	X	-	Precision Circlip Pliers Set	-	1.51
			48 11 J1	1	-
			48 11 J2	1	-
			49 11 A1	1	-
			49 11 A2	1	-
00 20 04 SB	X	-	Precision Circlip Pliers Set	-	2.81
			48 11 J1	1	-
			48 11 J2	1	-
			49 11 A1	1	-
			49 11 A2	1	-
			48 21 J11	1	-
			48 21 J21	1	-
			49 21 A11	1	-
			49 21 A21	1	-

Circlip Pliers Sets

00
20

- > contains the most common internal and external Circlip Pliers
- > internal design for fitting internal circlips in bore holes
- > external design for fitting circlips on shafts

00 20 03 V02

4 parts

00 20 04 V01

8 parts



00 20 03 V02



00 20 04 V01



Product Number	Packaging		Set contents	Units	lbs
00 20 03 V02	X	-	Set of Circlip Pliers	-	0.99
			44 11 J1	1	-
			44 11 J2	1	-
			46 11 A1	1	-
			46 11 A2	1	-
00 20 04 V01	X	-	Set of Circlip Pliers	-	1.96
			44 11 J1	1	-
			44 11 J2	1	-
			44 21 J11	1	-
			44 21 J21	1	-
			46 11 A1	1	-
			46 11 A2	1	-
			46 21 A11	1	-
			46 21 A21	1	-

Pliers Sets

in plastic deep-drawn packaging

00
20

> popular pliers sets in durable plastic packaging



00 20 05 US



00 20 06 US1



00 20 07 US1



00 20 08 US1



00 20 08 US2



00 20 06 US2

Product Number	Packaging		Set contents	Units	lbs
00 20 05 US	X	-	Set of High Leverage Diagonal Cutters	-	2.15
			74 01 160	1	-
			74 01 250	1	-
		$\angle 12^\circ$	74 21 200	1	-
00 20 06 US1	X	-	Cobra® Water Pump Pliers Set	-	2.69
			87 01 180	0	-
			87 01 250	0	-
			87 01 300	0	-
00 20 06 US2	X	-	Pliers Wrench Set	-	3.64
			86 03 180	1	-
			86 03 250	1	-
			86 03 300	1	-
00 20 07 US1	X	-	Alligator® Water Pump Pliers Set	-	2.65
			88 01 180	1	-
			88 01 250	1	-
			88 01 300	1	-
00 20 08 US1	X	-	Universal Pliers Set w/Alligator®	-	2.15
			26 11 200	1	-
		$\angle 12^\circ$	74 21 200	1	-
			88 01 250	1	-
00 20 08 US2	X	-	Universal Pliers Set w/Cobra®	-	2.15
			26 11 200	1	-
		$\angle 12^\circ$	74 21 200	1	-
			87 01 250	1	-

- > tools in plastic deep-drawn packaging with transparent lid
- > attractive sales packaging
- > dimensions (W x H x D):
6 3/4" x 15" x 1 1/2"

00 20 09 V01

Pliers with polished heads; handles with non-slip plastic coating or with two-color multi-component grips

00 20 10

Pliers with polished heads and plastic coated handles

00 20 11

Pliers with two-color multi-component handles



00 20 09 V01



00 20 10



00 20 11

Product Number	Packaging			Set contents	Units	⚖ lbs
00 20 09 V01	X	-	Bestseller Pack	-	-	2.09
			03 02 180	Combination Pliers	1	-
			70 02 160	Diagonal Cutter	1	-
			87 01 250	KNIPEX Cobra® High-Tech Water Pump Pliers	1	-
00 20 10	X	-	Power Pack	-	-	2.18
			02 01 180	High Leverage Combination Pliers	1	-
			74 01 160	High Leverage Diagonal Cutter	1	-
			87 01 250	KNIPEX Cobra® High-Tech Water Pump Pliers	1	-
00 20 11	X	-	Assembly Pack	-	-	1.79
			03 02 180	Combination Pliers	1	-
			26 12 200	Chain Nose Side Cutting Pliers (stork beak pliers)	1	-
			70 02 160	Diagonal Cutter	1	-

Electronics Pliers Sets

for working on electronic components

00
20

00 20 16

7 parts, contains 6 electronics pliers and one pair of precision tweezers; case made of hard-wearing polyester fabric, pliers are held by elastic band, zippered

00 20 16 P

6 parts, contains 6 precision electronics pliers; case made of hard-wearing polyester fabric, pliers are held by elastic band, zippered

00 20 16 P ESD

6 parts, contains 6 ESD precision electronics pliers, electrically discharging version; case made of hard-wearing polyester fabric, pliers are held by elastic band, zippered

00 20 17

6 parts, contains 6 ESD electronics pliers, electrically discharging version; case made of hard-wearing polyester fabric, pliers are held by elastic band, zippered

00 20 18

8 parts, contains 2 electronics pliers and 6 electronics screwdrivers; practical storage box, shock-resistant plastic, with foam insert

00 20 18 ESD

8 parts, contains 2 ESD electronics pliers and 6 electronics screwdrivers, electrically discharging version; practical storage box, shock-resistant plastic, with foam insert



00 20 16



00 20 16 P ESD



00 20 16 P



00 20 17



00 20 18



00 20 18 ESD



ESD Pliers (electrostatic discharge)

Electrostatic energy is discharged through the handles in a gradual and controlled manner which protects components endangered by electrostatic discharge in accordance with applicable standards, e.g. IEC TR 61 340-5, DIN EN 61 340-5, SP Method 2472



Product Number	Packaging	Set contents	lbs
00 20 16		35 12 115 / 35 22 115 / 35 32 115 / 64 32 120 / 77 02 115 / 77 42 115 / 92 34 36	1.59
00 20 16 P		34 12 130 / 34 22 130 / 34 32 130 / 79 02 120 / 79 02 125 / 79 42 125	1.27
00 20 16 P ESD		34 12 130 ESD / 34 22 130 ESD / 34 32 130 ESD / 79 02 120 ESD / 79 02 125 ESD / 79 42 125 ESD	1.29
00 20 17		35 12 115 ESD / 35 22 115 ESD / 35 42 115 ESD / 64 32 120 ESD / 77 02 115 ESD / 77 32 115 ESD	1.53
00 20 18		35 22 115 / 77 02 115 / screw drivers 0.4 x 2.5 / 0.5 x 3.0 / 0.6 x 3.5 / 0.8 x 4.0 / PH0 / PH1	1.01
00 20 18 ESD		35 22 115 ESD / 77 02 115 ESD / screw drivers 0.4 x 2.5 / 0.5 x 3.0 / 0.6 x 3.5 / 0.8 x 4.0 / PH0 / PH1	1.03

Mini Pliers Sets

in belt tool pouch

00
20

- > small tools that can be carried easily on any job
- > belt tool pouch can carry 2 tools up to 6" long
- > tool bag made of tough polyester fabric, with hook and loop fastening and belt loop
- > attractive cardboard packaging for merchandising
- > dimensions (W x H x D):
2 3/4 x 6 11/16 x 2" (70 x 170 x 50 mm)



00 20 72 V02

00 20 72 V01

Product Number	Packaging		Set contents	Units	lbs
00 20 72 V01	X	-	Mini pliers set in belt tool pouch	-	0.77
			86 03 150	Mini Pliers Wrench	1
			87 01 125	KNIPEX Cobra® High-Tech Water Pump Pliers	1
00 20 72 V02	X	-	Mini pliers set in belt tool pouch	-	0.86
			74 01 160	High Leverage Diagonal Cutter	1
			87 01 150	KNIPEX Cobra® High-Tech Water Pump Pliers	1
00 19 72 LE			Belt pouch for two pairs of pliers, empty		

Pliers Sets

2-Piece

00
31

- > perfect starter sets with our most popular pump pliers
- > 7 1/4" and 10" sizes
- > the Cobra Pliers set offers a push-button adjustment that stays set in place until you change it.
- > the Alligator Pliers set offers easy adjustment with 9 positions to find the perfect position



00 31 V01 US

00 31 20 V02

Product Number	Packaging		Set contents	Units	lbs
00 31 V01 US	X	-	Cobra® Water Pump Pliers Set	-	1.15
			87 01 180	KNIPEX Cobra® High-Tech Water Pump Pliers	1
			87 01 250	KNIPEX Cobra® High-Tech Water Pump Pliers	1
00 31 20 V02	X	-	Alligator® Water Pump Pliers Set	-	1.18
			88 01 180	KNIPEX Alligator® Water Pump Pliers	1
			88 01 250	KNIPEX Alligator® Water Pump Pliers	1

Tool Case "BIG Twin Move"

with integrated rollers and telescopic handle
empty

00
21

- > heavy-duty ABS material, black
- > all-round aluminum frame mounted sturdy center board, each side contains multi-purpose push-in facilities by elastic loops and 12 small pockets
- > pull-out handle embedded in the base and two integrated smooth in-line skater runners
- > 66 pound (30 kg) maximum load
- > can be opened on one or both sides (V form); base tray and cover can be partially or fully opened independently of each other; stands securely in all opening positions; the special runners are gentle on the floor and ensure stability
- > lockable
- > removable document compartment and removable tool panel with 13 tool pouches
- > base tray height 2 23/64" (60 mm), can be subdivided by flexible inserts; tool panel as cover plate with 13 tool pouches



00 21 41 LE

Product Number	Packaging	Dimension external (internal) width Inch mm	Dimension external (internal) height Inch mm	Dimension external (internal) depth Inch mm	lbs
00 21 41 LE		20 (18 7/8, 17 1/2) 510 (480/445)	10 5/8 (4 9/64) 270 (105)	16 9/64 (14 9/16, 13) 410 (370/330)	18.96





Effective protection against accidents caused by falling tools. The tether attachment is on the multi-component handles.

The tether attachment point for the range with multi-component handles

Tools can fall down anytime you are using them from a high height, for example; when using them on cherry pickers, scaffolding, ladders and by industrial climbers working with wire rope hoists.

KNIPEX offers a wide range of pliers and accessories that can reliably prevent the KNIPEX pliers from falling down.

There is a very stable tether attachment on the inside of the handles which is welded onto the handle for attaching the tether or adapter strap. The lug enables the equipment to be attached and put down quickly. The sophisticated elements from our KNIPEX Tethered Tools Program offers several individual variations for connection and use.

[Please read all warnings on product packaging carefully](#)

- > Do not use on live circuits. Always switch off power.
- > Always wear approved eye protection.
- > NO PPE = No Personal Protective Equipment.
- > Only for latching tools from the KNIPEX Tethered Tools range, connected and combined in accordance with this description.
- > Tether extends to length of around 5 feet (1.5 m) rig to avoid contact with objects below.
- > Do not use around moving or rotating equipment.
- > Will not support human weight.
- > Inspect for wear before each use. Do not use if evidence of wear.



Tether attachment: dynamic load capacity for a max. fall height of 10 ft / 3 m by a tool from the KNIPEX TT range.



The Tool Drop Protection System

for tools with tether attachment

- ▶ Versatile application potential ranging from building construction to industrial climbers
- ▶ Reliably prevents the tool from falling down, and can protect against serious injuries, damage to property or loss

Tether

00
50

- > wide working radius: flexible tether for user-friendly work
- > variable fastening options: with strap made of a flat belt sewn to one end and a cord and cord stopper sewn into the other end
- > suitable for all KNIPEX pliers with tether attachment



Adapter Straps

00
50

- > diverse options for fastening in combination with the carabiner and the tether
- > permits fast, safeguarded switching from the fastener on the tool bag to the tether and from one tool to another
- > suitable for all KNIPEX pliers with tether attachment



Carabiners

00
50

- > with screw lock to prevent accidental opening
- > strong and light aluminum design weighing just 1 ounce
- > for connecting adapter strap and tether or to attach these to a fixed point



00 50 04 T BKA: The complete tethering system set

The tether made of gathered fabric tape expands to a length of approx. 5' (1.5 m) when under strain

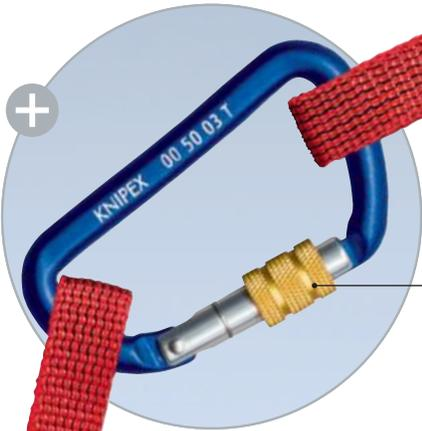
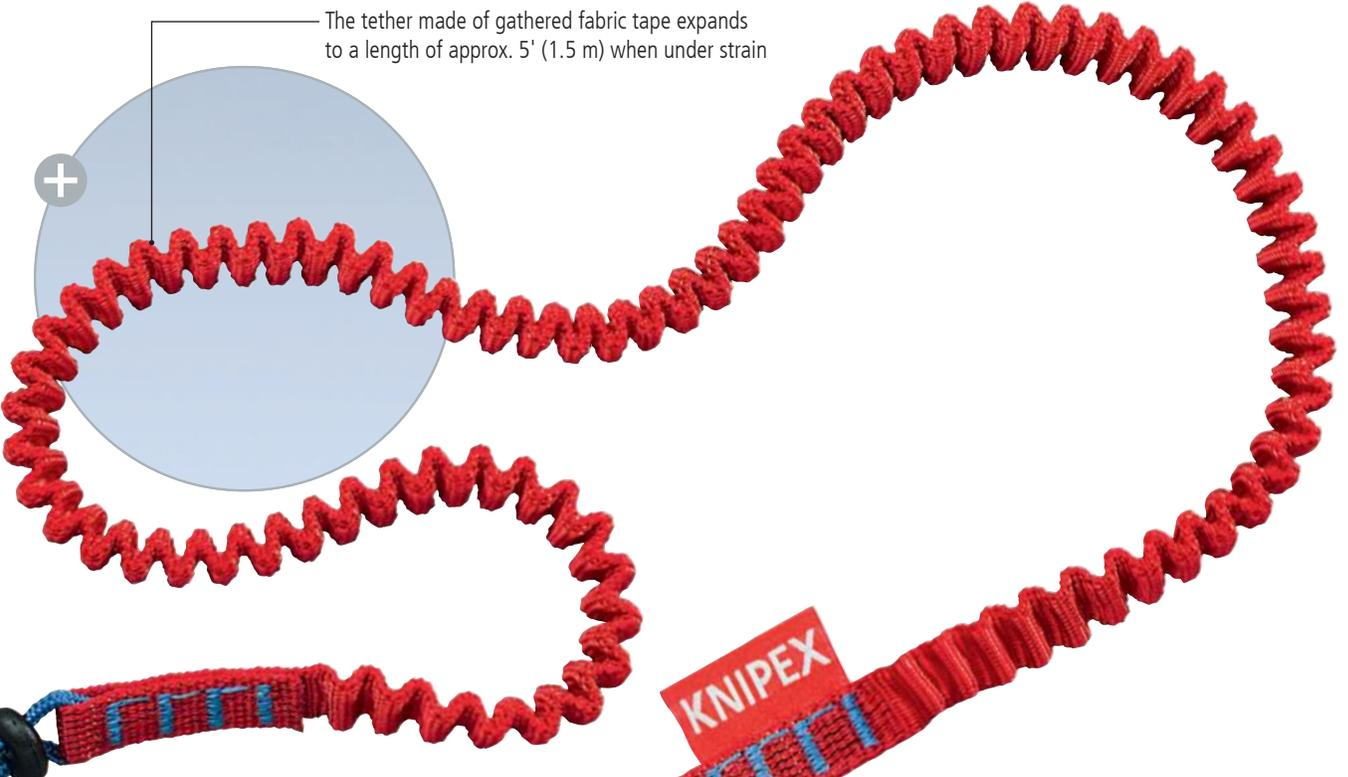

When tightened, the screw lock prevents inadvertent opening of the carabiner

KNIPEX



The adapter strap provides the flexible connection between tool and the reliable tether point

Read all warnings before using



Pliers with tether attachment point

Complete range



Pliers range with tether attachment point for a tool tether

	Product Number	Description
	02 02 225 T BKA black atramentized; head polished	High Leverage Combination Pliers, requires 35% less effort than conventional combination pliers
	08 22 145 T BKA black atramentized; head polished	Needle-Nose Combination Pliers, slim head for use in inaccessible work areas
	09 02 240 T BKA black atramentized; head polished	Lineman's Pliers, ultra-high leverage design for 25% easier cutting power
	09 12 240 T BKA black atramentized; head polished	09 12 240 T BKA: with a universal terminal crimper and a fish tape puller on the backside
	13 02 614 T BKA black atramentized; head polished	Electrician's Pliers, ideal for cable work, gripping and bending wire or even cutting medium hard and hard wire
	13 82 8 T BKA black atramentized; head polished	Electrical Installation Pliers, multifunctional 6-in-1 pliers for electrical installation; cutting, stripping, crimping, gripping, bending and deburring
	26 12 200 T BKA black atramentized; head polished	Long Nose Pliers w/Cutter, elastic precision tips will not deform or bend and will spring back into place
	26 22 200 T BKA black atramentized; head polished	26 22 200 T BKA: with 40° angled tips for hard to reach spaces
	71 02 200 T BKA black atramentized	KNIPEX CoBolt® Compact Bolt Cutters, particularly high cutting performance with little physical effort
	71 22 200 T BKA black atramentized	71 22 200 T BKA: 20° angled head with single-sided joint bar and diagonal cutting edge for almost flush cutting
	71 32 200 T BKA black atramentized	71 32 200 T BKA: notch in the blade for cutting thicker wire
	74 02 200 T BKA black atramentized; head polished	High Leverage Diagonal Cutters, high cutting performance with minimum effort. Available in 8" and 10" lengths
	74 02 250 T BKA black atramentized; head polished	12° angled head in a 8" length
	74 22 200 T BKA black atramentized; head polished	
	74 22 250 T BKA black atramentized; head polished	

Pliers range with tether attachment point for a tool tether

	Product Number	Description
	86 05 180 T BKA chrome plated	Pliers Wrenches, pliers and a wrench in a single tool, for damage free installation of plated fittings; Available in 7 1/4" and 10" lengths
	86 05 250 T BKA chrome plated	
	87 02 180 T BKA grey atramentized; head polished	KNIPEX Cobra® High-tech Water Pump Pliers, grips any shaped object – round, square, hex or flat. Push-button adjustment means that once the capacity is set, it stays set. Available in 7 1/4", 10" and 12" lengths
	87 02 250 T BKA grey atramentized; head polished	
	87 02 300 T BKA grey atramentized; head polished	
	88 02 250 T BKA black atramentized; head polished	KNIPEX Alligator® Water Pump Pliers, self-locking on pipes and nuts – no slipping off the workpiece, box-joint design for high stability. Available in 10" and 12" lengths
	88 02 300 T BKA black atramentized; head polished	
	95 12 165 T BKA burnished	Cable Shears, precision ground, hardened blades: clean and smooth cut without crushing and deformation
	95 62 190 T BKA head polished	Wire Rope Cutter, special blade geometry prevents the wire rope from fanning out

VDE Pliers range with tether attachment point for a tool tether

	Product Number	Description
	26 16 200 T chrome plated	N Snipe Nose Side Cutting Pliers, (Stork Beak Pliers), extremely durable, elastic precision tips; half-round, long, pointed jaws
	26 26 200 T chrome plated	N 26 16 200 T: straight 26 26 200 T: bent
	70 06 160 T chrome plated	N Diagonal Cutter, slim head for use in inaccessible work areas; available with fall protection in a compact length of 160 mm and a robust 180 mm length
	70 06 180 T chrome plated	N
	74 06 200 T chrome plated	N High Leverage Diagonal Cutters, high cutting performance with minimum effort; Available with fall protection in lengths of 200 mm and 250 mm
	74 06 250 T chrome plated	N
	87 26 250 T chrome plated	N KNIPEX Cobra® VDE, High-Tech Water Pump Pliers, push the button for adjustment on the workpiece and nuts
	95 16 165 T chrome plated	N Cable Shears, precision ground, hardened blades: clean and smooth cut without crushing and deformation

Drop protection system for tools with tether attachment point

	Product Number	Description
	00 50 01 T BK	N 1 x Tether Wide working radius: the tether made of gathered fabric tape expands to a length of approx. 1.5 m when under strain
	00 50 02 T BK	N 3 x Adapter straps Flexible connection between tool and the reliable tether point
	00 50 03 T BK	N 2 x Carabiner When tightened, the screw lock prevents inadvertent opening of the carabiner
	00 50 04 T BK	N Tethering System Set For diverse options for attaching KNIPEX pliers using the tether attachment (1 x Tether, 3 x Adapter straps, 2 x Carabiner)



Testing dielectric strength, subjecting each pair of pliers to a load of 10,000 V AC.

Insulated tools are a matter of trust

Professionals trust their tools. This trust is vital when working on electrical installations. In this case, the electrician holding the pliers is also holding his life in his hands. Our insulated tools therefore not only meet statutory requirements, but also offer the greatest possible safety, reliability and performance.





Testing the adhesion of the insulating coating at 500 N.



Pressure test at 70°C.



Low temperature impact test.



Testing the electrical insulating properties.

Regulated by standards

Only trained professionals are allowed to work on live installations. Such work is subject to strict occupational health and safety standards such as the German DIN VDE 0105, the international EN 50110 and IEC 60364 and the USA NFPA 70E. In each case they must deploy special tools that have been specifically manufactured and tested for this work. Tools used in live work must meet the requirements determined by DIN EN / IEC 60900 and NFPA 70E. KNIPEX tools which bear the special mark **⚡ 1000 V** are approved for work up to 1000 V AC.

Guaranteed individually checked

Every insulated tool undergoes, one by one, a dielectric strength at 10,000 V AC before we sell it. This means that work in the area up to 1,000 V AC has a safety buffer of ten times the permitted maximum limit. Other procedures check the reliability of the insulation towards heat, cold, tensile and impact force. In addition to the KNIPEX quality assurance team, external institutes and test centers such as the VDE guarantee that all insulated criteria have been satisfied. We stand by this responsibility with our name on the insulation of KNIPEX tools.

Strong beneath the insulation

The insulation provides safety when handling electrical installations, but the mechanical properties of the basic tool, such as cutting performance, precision and stability remain the other key-factor for a reliable function of insulated tools.

With our insulated pliers, users can depend on the quality and durability of products from KNIPEX production. For assembly tools insulated by us, we use basic tools from tried and tested suppliers whose quality we subject to regular, stringent checks. The expert can rely on this double dependability of tool and insulation.

Always comply with the current valid regulations and observe the SAFETY INSTRUCTIONS given below:

- > Insulated tools must be transported in a manner that will prevent any damage to the insulation.
- > Check before every use whether the insulation is damaged in any way, defective tools must be discarded.
- > Always keep your insulated tools clean and dry.
- > Wear protective goggles when working with cutting nippers or working overhead.
- > Always wear goggles or a facial mask when working on live equipment.
- > Make sure the workplace is clean and orderly, particularly when you are working on live installations.
- > Wear protective clothing and use SAFETY equipment (e.g. insulating gloves, insulating mats, protective covers) especially in confined working spaces.
- > Use only a tool with suitable dimensions. That will prevent slipping on the workpiece and unintentional contact with non-insulated parts.
- > Make sure that detached parts or cut-off ends of conductors do not fall onto live parts.

High Leverage Combination Pliers

DIN ISO 5746 IEC 60900 DIN EN 60900

02

35% less effort required than with conventional combination pliers
Cutting edge hardness (approx. 63 HRC) for heavy-duty cutting

- > easier work due to high leverage design
- > easier cutting, powerful gripping, bending and pulling
- > long cutting edges for thicker cables
- > gripping zones for flat and round material for a variety of uses
- > high-grade special tool steel; forged, multi stage oil-hardened



02 08 200 US

⚡ 1000V ASTM



02 08 225 US

⚡ 1000V ASTM

Product Number	Packaging	↔ Inch mm		Pliers	Head	Handles	Cutting capacities				
							⊘ Inch ⊘ mm	⊘ Inch ⊘ mm	⊘ Inch ⊘ mm	⊘ mm ²	⚖ lbs
02 08 200 US	X	8 200	⚡ 1000V ASTM	black atramentized	polished	insulated, multi-component grips, ASTM-tested	7/64 2.8	3/32 2.2	1/2 13.0	25.0	0.82
02 08 225 US	X	9 225					1/8 3.0	3/32 2.5	35/64 14.0	25.0	0.95

Combination Pliers

DIN ISO 5746 IEC 60900 DIN EN 60900

03

- > gripping zones for flat and round material for a variety of uses
- > cutting edges for soft and hard wire
- > long cutting edges for thicker cables
- > cutting edge hardness (approx. 60 HRC)
- > special tool steel; forged, multi stage oil-hardened



03 08 160 SBA

⚡ 1000V ASTM



03 08 200 SBA

⚡ 1000V ASTM

Product Number	Packaging	↔ Inch mm		Pliers	Head	Handles	Cutting capacities				
							⊘ Inch ⊘ mm	⊘ Inch ⊘ mm	⊘ Inch ⊘ mm	⊘ mm ²	⚖ lbs
03 08 160 SBA	X	6 1/4 160	⚡ 1000V ASTM	black atramentized	polished	insulated, multi-component grips, ASTM-tested	1/8 3.1	5/64 2.0	25/64 10.0	16.0	0.55
03 08 200 SBA	X	8 200					5/32 3.8	3/32 2.5	1/2 13.0	16.0	0.76

Needle-Nose Combination Pliers

DIN ISO 5746

08

Small high leverage combination pliers with pointed jaw For all common installation and repair work

Handy for use when working in confined areas due to slim head design and pointed jaws (anti-twist)

- > easy cutting due to the high leverage joint
- > cutting edges for soft, medium hard and hard wire
- > long service life and stable tips
- > high-grade special tool steel; forged, multi stage oil-hardened



08 28 145 US
⚡ 1000 V ASTM

Product Number	Packaging	↔ Inch mm	⚡ 1000 V ASTM	Pliers	Head	Handles	Cutting capacities				
							Ø Inch Ø mm	Ø Inch Ø mm	Ø Inch Ø mm	mm ²	lbs
08 28 145 US	X	5 3/4 145	⚡ 1000 V ASTM	black atramentized	polished	insulated, multi-component grips, VDE-tested	1/8 3.0	5/64 2.0	5/16 8.0	16.0	0.39

Lineman's Pliers

DIN ISO 5746 IEC 60900 DIN EN 60900

09

- > effective cross-hatched knurled gripping zone in the jaws – for strong gripping and pulling
- > cutting edges for soft and hard wire, nails, ACSR and piano wire
- > cutting edge hardness (approx. 64 HRC)
- > vanadium steel, forged, multi stage oil-hard



09 08 240 US
⚡ 1000 V ASTM

Product Number	Packaging	↔ Inch mm	⚡ 1000 V ASTM	Pliers	Head	Handles	Cutting capacities		
							Ø Inch Ø mm	Ø Inch Ø mm	lbs
09 08 240 US	X	9 1/2 240	⚡ 1000 V ASTM	black atramentized	polished	insulated, multi-component handles, ASTM-tested	3/16 4.6	1/8 3.0	1.02

Insulation Strippers

IEC 60900 DIN EN 60900

11

- > for single, multi and fine-stranded conductors with plastic or rubber insulation max. 13/64" (5.0 mm) dia., suitable for 8 AWG wire
- > easy adjustment to the required diameter of solid or stranded wire with knurled screw and lock nut
- > special tool steel; forged, oil-hardened



11 08 160 SBA
⚡ 1000 V ASTM

⚠ WARNING: This product can expose you to chemicals including lead, which is known to the State of California to cause cancer. For more information go to www.P65Warnings.ca.gov

Product Number	Packaging	↔ Inch mm	⚡ 1000 V ASTM	Pliers	Head	Handles	Stripping capacities		AWG	lbs
							Ø Inch Ø mm	mm ²		
11 08 160 SBA	X	6 1/4 160	⚡ 1000 V ASTM	black atramentized	polished	insulated, multi-component grips, ASTM-tested	13/64 5.0	10.0	up to 8	0.40

Installation Pliers

13

- > to grip flat and round material, for bending, deburring, cutting cable,
- > smooth surfaces near the tips grip single conductors without damaging them; serrated gripping surfaces and pipe grip for gripping flat and round material
- > clear-cut outside edge on the jaw for working on flush-mounted junction boxes and deburring feed-through holes
- > cable shears with induction hardened precision cutting edges
- > slim dimensions for easy access in confined areas
- > bolted joint: precise, zero-backlash operation of pliers
- > high-grade special tool steel; forged, multi stage oil-hardened

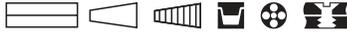

13 88 8 US

⚡ 1000 V ASTM 

Product Number	Packaging	↔ Inch mm	Pliers	Head	Handles	Cutting capacities		Stripping capacities for cross-sections AWG	Crimping capacities AWG	⚖ lbs	
						∅ Inch	AWG				
13 88 8 US	X	8 200	⚡ 1000 V ASTM 	black atramentized	polished	insulated, multi-component grips, ASTM-tested	9/16	0	12 and 14	12 - 20	0.60

Flat Nose Pliers

DIN ISO 5745 IEC 60900 DIN EN 60900

20

- > flat, short, wide jaws
- > serrated gripping surfaces
- > chrome vanadium electric steel; forged, oil-hardened

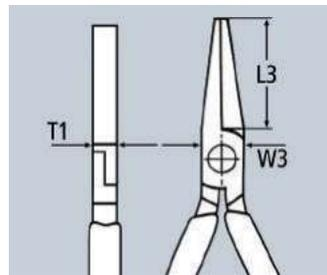

20 06 160

⚡ 1000 V 

Product Number	Packaging	↔ Inch mm	Pliers	Head	Handles	Dimensions			
						L3 Inch mm	W3 Inch mm	T1 Inch mm	⚖ lbs
20 06 160		6 1/2 165	⚡ 1000 V 	chrome plated	insulated, multi-component grips, VDE-tested	1 3/16 30.0	43/64 17.0	3/8 9.5	0.41

Round Nose Pliers

DIN ISO 5745 IEC 60900 DIN EN 60900

22

- > for bending wire loops
- > round, short jaws; smooth ground
- > smooth tips
- > special tool steel; forged, oil-hardened

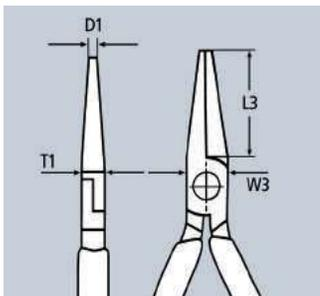

22 08 160 SBA

⚡ 1000 V ASTM

Product Number	Packaging	↔ Inch mm	Pliers	Head	Handles	Dimensions					
						L3 Inch mm	W3 Inch mm	D1 Inch mm	T1 Inch mm	⚖ lbs	
22 08 160 SBA	X	6 1/4 160	⚡ 1000 V ASTM	black atramentized	polished	insulated with multi-component grips, ASTM-tested	1 3/16 30.0	45/64 18.0	1/8 3.0	3/8 9.5	0.40

Snipe Nose Side Cutting Pliers

Radio Pliers, DIN ISO 5745 IEC 60900 DIN EN 60900

25

- > suitable for fine gripping and cutting work
- > pointed, half-round jaws
- > serrated gripping surfaces
- > cutting edges for soft, medium hard and hard wire
- > induction hardened cutting edges, cutting edge hardness (approx. 61 HRC)
- > vanadium steel; forged, multi stage oil-hardened



25 08 160 SBA

⚡ 1000 V ASTM ⊖  

Product Number	Packaging	↔ Inch mm	⚡ 1000 V ASTM ⊖  	Pliers	Head	Handles	Cutting capacities		Dimensions					⚖ lbs
							● Ø Inch Ø mm	● Ø Inch Ø mm	L3 Inch mm	W3 Inch mm	T1 Inch mm	W4 Inch mm	T2 Inch mm	
25 08 160 SBA	X	6 1/4 160	⚡ 1000 V ASTM ⊖  	black atramentized	polished	insulated, multi-component grips, ASTM-tested	3/32 2.5	1/16 1.6	1 31/32 50.0	21/32 16.5	23/64 9.0	1/8 3.0	3/32 2.5	0.34

Snipe Nose Side Cutting Pliers

Stork Beak Pliers

DIN ISO 5745 IEC 60900 DIN EN 60900

26

Elastic tips: stable even when twisted

- > distortion-tolerant, flexible precision tips
- > half-round, long, pointed jaws
- > with hardened cutting edges (approx. 61 HRC)
for soft, medium hard and hard wire
- > vanadium steel; forged, multi-stage oil-hardened



26 18 200 US

⚡ 1000 V ASTM ⊖  

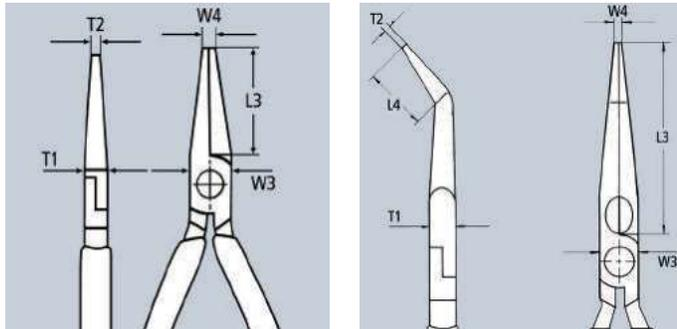

26 28 200 SBA

⚡ 1000 V ASTM $\angle 40^\circ$ ⊖  

Product Number	Packaging	↔ Inch mm	⚡ 1000 V ASTM ⊖  	Pliers	Head	Handles	Cutting capacities		Dimensions					⚖ lbs
							● Ø Inch Ø mm	● Ø Inch Ø mm	L3 Inch mm	T1 Inch mm	W3 Inch mm	W4 Inch mm	T2 Inch mm	
26 18 200 US	X	8 200	⚡ 1000 V ASTM ⊖  	black atramentized	polished	insulated, multi-component grips, ASTM-tested	1/8 3.2	3/32 2.2	2 7/8 73.0	3/8 9.5	45/64 18.0	1/8 3.0	3/32 2.5	0.45
26 28 200 SBA	X	8 200	⚡ 1000 V ASTM $\angle 40^\circ$ ⊖  	black atramentized	polished	insulated, multi-component grips, ASTM-tested	1/8 3.2	3/32 2.2	2 7/8 73.0	3/8 9.5	45/64 18.0	1/8 3.0	3/32 2.5	0.46

Long Nose Pliers

DIN ISO 5745 IEC 60900 DIN EN 60900

30

- > heavy-duty and hard-wearing gripping pliers
- > different jaw styles for a wide range of applications
- > chrome vanadium electric steel; forged, oil-hardened

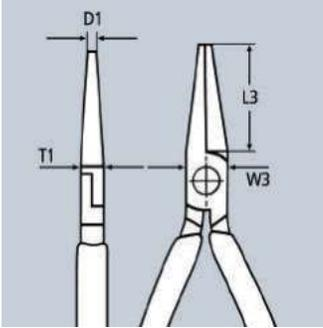

30 16 160



30 36 160



Style 1

Long, trapezoidal jaws; serrated gripping surfaces

Style 3

Long, round jaws; smooth gripping surfaces

Product Number	Packaging	↔ Inch mm	Icons	Pliers	Handles	Style	Dimensions					⚖ lbs
							L3 Inch mm	W3 Inch mm	T1 Inch mm	W4 Inch mm	T2 Inch mm	
30 16 160		6 1/4 160	⚡ 1000V	chrome plated	insulated, multi-component grips, VDE-tested	1	1 53/64 46.5	21/32 16.5	3/8 9.5	1/8 3.0	13/64 5.0	0.33
30 36 160		6 1/4 160	⚡ 1000V	chrome plated	insulated, multi-component grips, VDE-tested	3	1 19/32 41.0	21/32 16.5	3/8 9.5	13/64 5.0	3/32 2.5	0.31

Diagonal Cutters

DIN ISO 5749 IEC 60900 DIN EN 60900

70

- > essential cutting tool for all-around use
- > high-quality material and precise workmanship for long service life
- > precision cutting edges for soft and hard wire
- > clean cutting of thin copper wires even at the cutting edge tips
- > induction hardened cutting edges (approx. 62 HRC)
- > narrow head style for use in confined areas
- > vanadium steel; forged, multi stage oil-hardened
- > 70 26 160 has a strong precision rivet for smooth movement and 20% higher cutting force



70 08 180 SBA

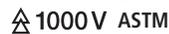

70 26 160

With elongated cutting edge

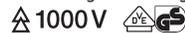

Slim head style and precise cutting capability are perfect for working in confined areas

Product Number	Packaging	↔ Inch mm	Icons	Pliers	Head	Handles	Cutting capacities			⚖ lbs
							⊘ Inch ⊘ mm	⊘ Inch ⊘ mm	⊘ Inch ⊘ mm	
70 08 160 SBA	X	6 1/4 160	⚡ 1000V	black atramentized	polished	insulated, multi-component handles, ASTM-tested	5/32 4.0	1/8 3.2	5/64 2.0	0.49
70 08 180 SBA	X	7 1/4 180					5/32 4.0	1/8 3.0	3/32 2.5	0.58
70 26 160		6 1/4 160	⚡ 1000V	chrome plated		insulated, multi-component grips, VDE-tested	5/32 4.0	1/8 3.0	5/64 2.0	0.51

KNIPEX X-Cut®
Compact Diagonal Cutter
IEC 60900 DIN EN 60900

73

Powerful, light and universal

Cuts fine strands as well as multi-stranded cables and piano wires

- > box-joint design: highest stability with low weight
- > high cutting performance with minimum effort due to optimum coordination of the cutting edge angle and transmission ratio
- > large opening width for thicker cables
- > cuts all wires precisely, even fine copper wires
- > double supported joint axis for heavy-duty work
- > compact, lightweight construction
- > universal usage in the assembly, maintenance and production
- > chrome vanadium heavy-duty steel; forged, multi stage oil-hardened



73 06 160



X-Cut®

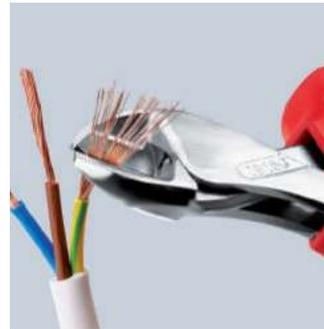

40% less effort required
compared with standard diagonal cutters of the same length with double mounted hinged joint.

Product Number	Packaging	↔ Inch mm	Pliers	Handles	Cutting capacities					⚖ lbs
					⊘ Inch ⊘ mm	⊘ Inch ⊘ mm	⊘ Inch ⊘ mm	⊘ Inch ⊘ mm	⊘ Inch ⊘ mm	
73 06 160		6 1/4 160	chrome plated	insulated, multi-component grips, VDE-tested	3/16 4.8	5/32 3.8	7/64 2.7	3/32 2.2	15/32 12.0	0.41

High Leverage Diagonal Cutters
DIN ISO 5749 IEC 60900 DIN EN 60900

74

- > forged-on axle for heavy-duty work
- > for very tough, continuous use
- > high cutting performance with minimum effort due to optimum coordination of the cutting edge angle and transmission ratio
- > precision cutting edges induction hardened (approx. 64 HRC) cuts several types of wire including piano wire
- > chrome vanadium heavy-duty steel; forged, multi stage oil-hardened

78 08 250 SBA

The 10" long diagonal cutter is suitable for copper conductors up to 16 mm² and aluminum conductors up to 35 mm²



74 08 200 US



20% less effort required
compared to conventional diagonal cutters of the same length, with forged-on joint axle.

Product Number	Packaging	↔ Inch mm	Pliers	Head	Handles	Cutting capacities			⚖ lbs
						⊘ Inch ⊘ mm	⊘ Inch ⊘ mm	⊘ Inch ⊘ mm	
74 08 200 US	X	8 200		polished	insulated, multi-component handles, ASTM-tested	11/64 4.2	1/8 3.0	3/32 2.5	0.68
74 08 250 US	X	10 250	black atramentized	polished		3/16 4.6	9/64 3.5	1/8 3.0	1.04

Pliers Wrench

insulated

IEC 60900 DIN EN 60900

86
07

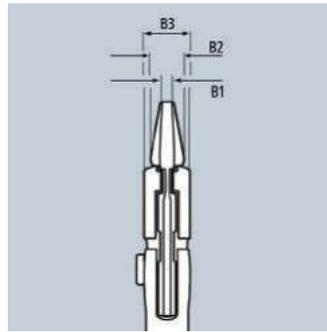

Scale for setting the opening width off the workpiece (metric on the front and imperial on the back)

- > pliers and a wrench in a single tool
- > excellent for gripping, holding, pressing and bending applications
- > zero backlash jaw surface pressure prevents damage to edges of sensitive components
- > opening width lasered onto the pliers head for setting before putting the tool on the workpiece
- > adjustment at the touch of a button directly on the workpiece
- > parallel jaws allow infinitely variable gripping of all widths to the specified maximum size
- > the action of the jaws allows bolted connections to be tightened and released quickly using the ratchet principle
- > lever transmission greater than 10 - 1 for strong gripping power
- > chrome vanadium electric steel; forged, oil-hardened



86 06 250 US
⚡ 1000 V

Product Number	Packaging	↔ Inch mm	⚡ 1000 V	Pliers	Handles	⏏ Inch mm	Adjustment positions	Dimensions			⚖ lbs
								B1 Inch mm	B2 Inch mm	B3 Inch mm	
86 06 250 US	X	10 250	⚡ 1000 V	chrome plated	Insulated, multi-component grips, VDE-tested	2 52	19	5/16 8	5/16 8	35/64 14	1.14

KNIPEX Alligator®

Water Pump Pliers

DIN ISO 8976 IEC 60900 DIN EN 60900

88

More output and comfort compared to conventional water pump pliers of the same length: offers 9 adjustment positions for 30% more gripping capacity

- > good access to the workpiece due to slim size in the head and joint area
- > self-locking on pipes and nuts: no slipping off the workpiece and low handforce required
- > gripping surfaces with special hardened teeth, teeth hardness (approx. 61 HRC): low wear and reliable gripping
- > box-joint design: high stability because of double guide
- > pinch guard prevents operators' fingers being pinched
- > chrome vanadium electric steel; forged, multi stage oil-hardened



88 07 300
⚡ 1000 V



88 08 250 US
⚡ 1000 V ASTM

Product Number	Packaging	↔ Inch mm	⚡ 1000 V	Pliers	Head	Handles	○	⏏	Adjustment positions	⚖ lbs
							∅ Inch ∅ mm	Inch mm		
88 07 300	X	12 300	⚡ 1000 V	chrome plated	chrome plated	plastic dipped insulated, VDE-tested	2 3/4 70	2 3/64 60	9	1.46
88 08 250 US	X	10 250	⚡ 1000 V ASTM	black atramentized	polished	insulated, multi-component handles, ASTM-tested	1 31/32 50	1 13/16 46	9	0.87

KNIPEX Cobra®

High-Tech Water Pump Pliers, insulated
 DIN ISO 8976 IEC 60900 DIN EN 60900

87
 26

- > adjustment by shifting the jaw directly on to the workpiece: fast, secure and comfortable handling
- > opening at the touch of a button apart from the workpiece
- > fine adjustment for optimum adaptation to different workpiece sizes and comfortable gripping position
- > good access to the workpiece due to slim size in the head and joint area
- > self-locking on pipes and nuts: no slipping off the workpiece and low handforce required
- > gripping surfaces with special hardened teeth, teeth hardness (approx. 61 HRC): low wear and reliable gripping
- > box-joint design: high stability because of double guide
- > pinch guard prevents operators' fingers being pinched
- > chrome vanadium electric steel; forged, multi stage oil-hardened



87 28 250 US
 ⚡ 1000 V ASTM

The adjustment action to adapt to the workpiece is easy and reliable with the KNIPEX Cobra®: place the upper gripping jaw on the workpiece, push pliers to close, done!



Quick adjustment to the workpiece without using a push-button

Just push the pliers handle to adjust

Product Number	Packaging	↔ Inch mm		Pliers	Head	Handles	∅ Inch	∅ Inch ∅ mm	∅ Inch mm	Adjustment positions	⚖ lbs
87 28 250 US	X	10 250	⚡ 1000 V ASTM 🔧🔩	grey atramentized	polished	insulated, multi-component grips, ASTM-tested	2	1 31/32 50	1 13/16 46	24	0.88

Precision Tweezers

IEC 60900 DIN EN 60900

92

- > insulated and tested according to IEC 60900
- > plastic dipped insulated
- > chrome plated
- > spring steel, high-strength

92 27 61

For ultra fine mounting work; extra fine tips; straight tips; gripping surfaces matte finish for optimum grip

92 27 62

Straight tips; gripping surfaces with fine transverse serration

92 37 64

Bent tips; gripping surfaces with fine transverse serration

92 67 63

Straight tips; serrated gripping surfaces



92 27 61

△ 1000 V ✱ ◁



92 27 62

△ 1000 V ✱ ▨



92 37 64

△ 1000 V ✱ ∠45° ▨



92 67 63

△ 1000 V ✱ ▨

Product Number	Packaging	↔ Inch mm		Finish	⚖ lbs
92 27 61		5 1/8 130	△ 1000 V ✱ ◁	plastic dipped insulated, VDE-tested	0.07
92 27 62		6 150	△ 1000 V ✱ ▨	plastic dipped insulated, VDE-tested	0.08
92 37 64		6 150	△ 1000 V ✱ ∠45° ▨	plastic dipped insulated, VDE-tested	0.08
92 67 63		5 3/4 145	△ 1000 V ✱ ▨	plastic dipped insulated, VDE-tested	0.10

Cable Shears

IEC 60900 DIN EN 60900

95

0

- > for cutting copper and aluminum cables
- > not suitable for steel wire and hard drawn copper conductors
- > precision ground, hardened blades
- > no crushing, slight deformation of the cable only
- > with pinch guard and slip guard
- > adjustable bolted joint
- > shears body: surgical steel, stainless, vacuum-hardened
- > handles: plastic, impact-resistant

95 06 230

For copper conductors single wire up to 5/8" (16 mm²), multi-stranded wire up to 1/0 AWG (50 mm²), fine stranded up to 70 mm² and aluminum conductors multi-stranded wire up to 70 mm²; Easy cutting with one-hand operation due to high transmission ratio; stainless – surgical grade – steel; oil-hardened and tempered



95 06 230

△ 1000 V ⚡ ⚙ ⚙ ⚙ ⚙

Product Number	Packaging	↔ Inch mm		Head	Handles	Cutting capacities		AWG	⚖ lbs
						⊘ Inch ⊘ mm	mm ²		
95 06 230		9 1/4 230	△ 1000 V ⚡ ⚙ ⚙ ⚙ ⚙	polished	plastic insulated, VDE-tested	5/8 16	50	Solid - 1/0 Stranded - 2/0	0.60

Cable Shears

IEC 60900 DIN EN 60900

95
1

- > for cutting copper and aluminum cables, single and multi-stranded wires
- > not suitable for steel wire and hard drawn copper conductors
- > precision ground, hardened blades
- > clean and smooth cut without crushing and deformation
- > easy cutting with one-hand operation
- > pinch guard prevents operators' fingers being pinched
- > adjustable bolted joint, self-locking
- > high-grade special tool steel; forged, oil-hardened



Cut performed with a Diagonal Cutter: high effort required, inaccurate cut, considerable deforming and crushing of the cable.



Cut performed with a Cable Shear: easy, clean cut without any deformation of the cable.



95 18 165 US
⚡ 1000 V ASTM ⚡

Product Number	Packaging	↔ Inch mm	Tool	Handles	Cutting capacities			AWG	⚖ lbs
					⚡ Ø Inch Ø mm	⚡ mm ²	⚡		
95 18 165 US	X	6 1/2 165	⚡ 1000 V ASTM ⚡	burnished	insulated, multi-component grips, ASTM-tested	19/32 15	50	1/0	0.58

Cable Shears

with twin cutting edge

IEC 60900 DIN EN 60900

95
1

- > for cutting copper and aluminum cables
- > not suitable for steel wire and hard drawn copper conductors
- > precision ground, hardened blades
- > clean and smooth cut without crushing and deformation
- > easy cutting with one-hand operation
- > by dividing the cutting actions into initial cut (insulating sheath in the front cutting area) and final cut (conductor in the back cutting area), cables up to 25/32" (20 mm) dia. can be cut in one-hand operation
- > less effort required due to favorable lever ratio and special blade geometry
- > pinch guard prevents operators' fingers being pinched
- > adjustable bolted joint, self-locking
- > high-grade special tool steel; forged, oil-hardened



Initial cut: using the front cutting edge to cut the insulating sheath on larger cable diameters leaves an ergonomic handle opening width.



Final cut: after cutting the sheath in the front profile the conductors are cut in the rear area.



95 18 200 SBA
⚡ 1000 V ASTM ⚡ ⚡ PATENTED

Product Number	Packaging	↔ Inch mm	Tool	Handles	Cutting capacities			AWG	⚖ lbs
					⚡ Ø Inch Ø mm	⚡ mm ²	⚡		
95 18 200 SBA	X	8 200	⚡ 1000 V ASTM ⚡ ⚡	burnished	insulated, multi-component grips, ASTM-tested	25/32 20	70	2/0	0.75

Cable Shears

IEC 60900 DIN EN 60900

95
1

Short design, length only 20" (500 mm)
Lightweight, high leverage



Large cutting capacity: max. 1 1/16" (27 mm) dia./150 m²

- > insulated and tested according to IEC 60900 and ASTM F1505
- > for cutting copper and aluminum cables, single and multi-stranded wires
- > not suitable for steel wire and wire ropes
- > precision ground, hardened blades
- > clean and smooth cut without crushing and deformation
- > less effort required due to favorable lever ratio and optimized cutting edge geometry
- > pinch guard prevents operators' fingers being pinched
- > adjustable bolted joint
- > cutter head: vanadium electric steel; forged, oil-hardened
- > handle shank: aluminum tube, high-strength



95 17 500

⚠ 1000 V    

Product Number	Packaging	↔ Inch mm		Head	Handles	Cutting capacities		AWG	⚖ lbs
						⊘ Inch ⊘ mm	⊘ mm ²		
95 17 500		20 500	⚠ 1000 V    	burnished	plastic dipped insulated, VDE-tested	1 1/16 27	150	5/0	3.26

Cable Shears

IEC 60900 DIN EN 60900

95
2

- > for cutting copper and aluminum cables, single and multi-stranded wires
- > not suitable for steel wire and wire ropes
- > precision ground, hardened blades
- > clean and smooth cut without crushing and deformation
- > favorable lever ratio due to toggle lever
- > pinch guard prevents operators' fingers being pinched
- > adjustable bolted joint
- > bolted cutter head, replaceable
- > blade head: high-grade chrome vanadium electric steel; forged, oil-hardened
- > handle: steel tube



95 27 600

⚠ 1000 V    

Product Number	Packaging	↔ Inch mm		Head	Handles	Cutting capacities		AWG	⚖ lbs
						⊘ Inch ⊘ mm	⊘ mm ²		
95 27 600		23 1/2 600	⚠ 1000 V    	polished	plastic dipped insulated, VDE-tested	1 1/16 27	150	5/0	5.08

95 29 600 Spare cutter head for 95 27 600

Cable Cutters

with ratchet action
IEC 60900 DIN EN 60900

95
3

- > for cutting copper and aluminum cables, single and multi-stranded wires
- > not suitable for steel wire and wire ropes
- > precision ground, hardened blades
- > clean and smooth cut without crushing and deformation
- > one-hand operation using ratchet principle
- > minimal handforce required due to very high transmission ratio
- > two-stage ratchet drive for easy cutting
- > simple handling as a result of lightweight and compact design – can be used even in confined areas
- > pinch guard prevents operators' fingers being pinched
- > high-grade special tool steel; forged, oil-hardened



Ratchet principle and two-stage ratchet drive for easier cutting



95 36 250 SBA

⚠ 1000 V



95 36 280 SBA

⚠ 1000 V

Product Number	Packaging	↔ Inch mm		Tool	Handles	Cutting capacities			⚖ lbs
						⊕ Ø Inch Ø mm	⊕ mm ²	MCM	
95 36 250 SBA	X	10 250	⚠ 1000 V	black lacquered	insulated, multi-component grips, VDE-tested	1 1/4 32	240	500	1.24
95 36 280 SBA	X	11 280	⚠ 1000 V	black lacquered	insulated, multi-component grips, VDE-tested	2 3/64 52	380	750	1.64



Cable Cutter

ratchet principle, 3-stage
IEC 60900 DIN EN 60900

95
3

Sturdy. Easy to use.
Innovative ratchet-drive.

- > insulated and tested according to IEC 60900 and ASTM F1505
- > easy handling due to lightweight (1.82 lbs) and compact construction 12 1/2" (320 mm) length – usable in confined areas
- > cuts through copper and aluminum cables with diameters of up to 2 23/64" (60 mm) in one-hand and two-handed operations
- > hardened cutting edges, precisely ground, cut smoothly and neatly without crushing
- > for cutting copper and aluminum single conductors as well as multi-stranded cables (not suitable for steel wire and wire ropes)
- > innovative 3-stage ratchet-drive with high leverage for easy cutting in one-hand and two-handed operation
- > fixed handle with support area for laying down the pliers when cutting
- > high-grade special tool steel; forged, oil-hardened



95 36 320



Product Number	Packaging	↔ Inch mm	Tool	Handles	Cutting capacities			
					Ø Inch Ø mm	mm ²	MCM	lbs
95 36 320		12 1/2 320	⚡ 1000V ⚠️ ⚙️ ⚙️ ⚙️ ⚙️	black atramentized insulated, multi-component grips, VDE-tested	2 3/64 60	600	1200	1.83
95 39 320 01	Pivot cutter repair kit for 95 36 320							
95 39 320 02	Fixed cutter repair kit for 95 36 320							



Cable Cutters for Wire Rope and ACSR

IEC 60900 DIN EN 60900

95
7

- > for ACSR, wire ropes, steel rods, copper and aluminum cables
- > suitable for cutting overhead line cables with strain relief wire
- > angular cutting blades prevent fanning out
- > optimum transmission ratio for high cutting performance
- > bolted cutter head, replaceable
- > lightweight
- > cutter head: high-grade special tool steel, multi stage oil-hardened
- > handles: aluminum, high-strength



95 77 600

⚡ 1000 V 

Product Number	Packaging	↔ Inch mm	Head	Handles	Cutting capacities					
					 mm ²	 Ø Inch Ø mm	 Ø Inch Ø mm	AWG	 lbs	
95 77 600		23 5/8 600	⚡ 1000 V 	polished	plastic dipped insulated	150	35/64 14	23/64 9	5/0	5.02
95 79 600	Spare cutter head for 95 77 600									

Crimping Pliers

for wire ferrules (end sleeves)

IEC 60900 DIN EN 60900

97
68

- > for crimping wire end ferrules according to DIN 46228 parts 1 and 4 in an area of application from 24 - 14 AWG (0.25 up to 2.5 mm²)
- > crimping in marked trapezoidal dies for tight connections between the sleeve and the conductor
- > vanadium electric steel; forged, oil-hardened



97 68 145 A

 ⚡ 1000 V 



Product Number	Packaging	↔ Inch mm	Head	Handles	Capacity mm ²	AWG	Number of crimping positions	 lbs	
									97 68 145 A

Open End Wrenches

IEC 60900 DIN EN 60900

98
0

- > jaw 15° angled
- > chrome plated
- > chrome vanadium steel; forged, oil-hardened



98 00 14
⚡ 1000V ○

Metric Versions

Product Number	Packaging		Length l max. Inch mm	Width across flats S Inch mm	Head width b max. Inch mm	Head thickness a max. Inch mm	⚖ lbs
98 00 07		⚡ 1000V ○	4 1/8 105.0	7.0	25/32 20.0	5/32 4.0	0.06
98 00 08			4 1/8 105.0	8.0	55/64 22.0	5/32 4.0	0.07
98 00 09			4 1/8 105.0	9.0	15/16 24.0	5/32 4.0	0.08
98 00 10			4 1/8 105.0	10.0	1 1/16 27.0	13/64 5.0	0.11
98 00 11			4 3/4 120.0	11.0	1 3/16 30.0	7/32 5.5	0.12
98 00 12			5 125.0	12.0	1 1/4 32.0	7/32 5.5	0.15
98 00 13			5 1/8 130.0	13.0	1 11/32 34.0	1/4 6.5	0.15
98 00 14			5 1/4 135.0	14.0	1 3/8 35.0	1/4 6.5	0.14
98 00 15			5 3/4 145.0	15.0	1 29/64 37.0	9/32 7.0	0.20
98 00 16			6 7/64 155.0	16.0	1 1/2 38.0	9/32 7.0	0.25
98 00 17			6 7/64 155.0	17.0	1 21/32 42.0	5/16 8.0	0.26
98 00 18			6 1/4 160.0	18.0	1 3/4 44.0	5/16 8.0	0.33
98 00 19			6 1/2 165.0	19.0	1 27/32 47.0	23/64 9.0	0.31
98 00 22			7 1/2 190.0	22.0	2 3/64 52.0	23/64 9.0	0.48
98 00 24			8 1/4 210.0	24.0	2 13/64 56.0	23/64 9.0	0.54
98 00 27			8 1/2 215.0	27.0	2 31/64 63.0	23/64 9.0	0.70

Imperial Versions

Product Number	Packaging		Length l max. Inch mm	Width across flats S Inch mm	Head width b max. Inch mm	Head thickness a max. Inch mm	⚖ lbs
98 00 3/4"		⚡ 1000V ○	7 1/2 190.5	3/4	1 27/32 47.0	23/64 9.0	0.34
98 00 3/8"			4 1/4 108.0	3/8	1 1/16 27.0	13/64 5.0	0.09
98 00 5/16"			4 1/4 108.0	5/16	55/64 22.0	5/32 4.0	0.09
98 00 5/8"			6 1/2 165.1	5/8	1 1/2 38.0	9/32 7.0	0.26
98 00 7/16"			4 3/4 120.7	7/16	1 3/16 30.0	7/32 5.5	0.11
98 00 9/16"			6 152.4	9/16	1 3/8 35.0	1/4 6.5	0.21
98 00 1/2"			5 1/2 139.7	1/2	1 11/32 34.0	1/4 6.5	0.18
98 00 1/4"			4 1/4 108.0	1/4	25/32 20.0	5/32 4.0	0.08

Adjustable Wrench

IEC 60900 DIN EN 60900

98
07

- > parallel smooth gripping jaws
- > adjustable gripping width
- > with scaling for presetting the width apart from the workpiece
- > chrome vanadium steel



98 07 250

⚡ 1000 V  $\sphericalangle 22^\circ$ 

Product Number	Packaging	↔ Inch mm		Tool	Handle	 Inch mm	Jaw width Inch mm	Head width Inch mm	Width Inch mm	Depth Inch mm	 lbs
98 07 250		10 1/4 260	⚡ 1000 V  $\sphericalangle 22^\circ$ 	chrome plated	plastic dipped insulated, VDE-tested	1 3/16 30	5/16 8.0	5/8 16.0	2 7/8 73.0	25/32 20.0	1.2



- > cranked
- > chrome plated
- > chrome vanadium steel; forged, oil-hardened



98 01 14
⚡ 1000 V ○

Metric Versions

Product Number	Packaging		Length l max. Inch mm	Width across flats S Inch mm	Head width b max. Inch mm	Head thickness a max. Inch mm	Depth of crank h max. Inch mm	⚖ lbs
98 01 07		⚡ 1000 V ○	6 150.0	7.0	15/32 12.0	9/32 7.0	45/64 18.0	0.13
98 01 08			6 7/64 155.0	8.0	35/64 14.0	9/32 7.0	3/4 19.0	0.13
98 01 09			6 1/2 165.0	9.0	39/64 15.5	5/16 8.0	3/4 19.0	0.17
98 01 10			6 1/4 160.0	10.0	43/64 17.0	23/64 9.0	25/32 20.0	0.17
98 01 11			6 1/2 165.0	11.0	47/64 18.5	25/64 10.0	53/64 21.0	0.19
98 01 12			7 1/4 185.0	12.0	47/64 18.5	25/64 10.0	29/32 23.0	0.24
98 01 13			7 1/4 185.0	13.0	53/64 21.5	7/16 11.0	29/32 23.0	0.25
98 01 14			7 1/2 195.0	14.0	29/32 23.0	15/32 12.0	15/16 24.0	0.30
98 01 15			8 200.0	15.0	15/16 24.0	15/32 12.0	15/16 24.0	0.34
98 01 16			8 200.0	16.0	1 1/32 26.0	15/32 12.0	1 1/32 26.0	0.38
98 01 17			8 205.0	17.0	1 1/16 27.0	1/2 13.0	1 1/32 26.0	0.38
98 01 18			8 1/4 210.0	18.0	1 9/64 29.0	1/2 13.0	1 7/64 28.0	0.53
98 01 19			8 3/4 225.0	19.0	1 3/16 30.0	35/64 14.0	1 7/64 28.0	0.54
98 01 22			8 3/4 225.0	22.0	1 3/8 35.0	19/32 15.0	1 3/16 30.0	0.61

Imperial Versions

Product Number	Packaging		Length l max. Inch mm	Width across flats S Inch mm	Head width b max. Inch mm	Head thickness a max. Inch mm	Depth of crank h max. Inch mm	⚖ lbs
98 01 1 1/16"		⚡ 1000 V ○	10 7/16 265.0	1 1/16	1 1/2 38.0	5/8 16.0	1 3/16 30.0	1.21
98 01 11/16"			8 205.0	11/16	1 1/16 27.0	1/2 13.0	1 1/32 26.0	0.41
98 01 3/4"			8 3/4 225.0	3/4	1 3/16 30.0	35/64 14.0	1 7/64 28.0	0.55
98 01 5/16"			6 7/64 155.0	5/16	35/64 14.0	9/32 7.0	3/4 19.0	0.15
98 01 5/8"			8 200.0	5/8	1 1/32 26.0	15/32 12.0	1 1/32 26.0	0.45
98 01 7/8"			8 3/4 225.0	7/8	1 3/8 35.0	19/32 15.0	1 3/16 30.0	0.70
98 01 9/16"			7 1/2 195.0	9/16	29/32 23.0	15/32 12.0	15/16 24.0	0.36

Nut Drivers

with T-Handle

IEC 60900 DIN EN 60900

98
0

> special tool steel, oil-hardened



98 04 13



98 05 13



Product Number	Packaging	↔ Inch mm		Width across flats S mm	Handle length Inch mm	Head dia. Inch mm	⚖ lbs
98 04 10		8 200	⚠ 1000 V ⚠ ⚠ ⚠	10.0	6 7/64 155	3/4 19.5	0.80
98 04 13		8 200		13.0	6 7/64 155	59/64 23.5	0.81
98 04 17		8 200		17.0	6 7/64 155	1 1/8 28.5	1.06
98 04 19		8 200		19.0	6 7/64 155	1 7/32 31.0	1.31
98 04 22		8 200		22.0	6 7/64 155	1 23/64 34.5	1.42
98 05 13		12 300	⚠ 1000 V ⚠ ⚠ ⚠	13.0	6 7/64 155	59/64 23.5	0.94
98 05 17		12 300		17.0	6 7/64 155	1 1/8 28.5	1.24
98 05 19		12 300		19.0	6 7/64 155	1 7/32 31.0	1.56

Screwdrivers for Hexagon Socket Screws

with T-Handle

IEC 60900 DIN EN 60900

98
1

> special tool steel, oil-hardened



98 14 08
⚠ 1000 V ○



98 15 08
⚠ 1000 V ○



Product Number	Packaging	↔ Inch mm		Width across flats S mm	Length of non-insulated blade ± 2 Inch mm	T-Handle width Inch mm	⚖ lbs
98 14 05		4 3/4 120	⚠ 1000 V ○	5.0	23/64 9.0	3 1/2 90.0	0.49
98 14 06		4 3/4 120		6.0	25/64 10.0	3 1/2 90.0	0.46
98 14 08		4 3/4 120		8.0	7/16 11.0	3 1/2 90.0	0.63
98 15 05		10 250	⚠ 1000 V ○	5.0	23/64 9.0	3 1/2 90.0	0.80
98 15 06		10 250		6.0	25/64 10.0	3 1/2 90.0	1.00
98 15 08		10 250		8.0	7/16 11.0	3 1/2 90.0	0.79

T-handle

with driving square 3/8" or 1/2"

IEC 60900 DIN EN 60900

98
40

- > for use with sockets
- > for quick, easy and secure locking of attached sockets
- > chrome plated
- > high-grade special tool steel; forged, oil-hardened



98 40
⚠ 1000 V 1/2

Product Number	Packaging	↔ Inch mm		Handle length Inch mm	Square drive Inch	⚖ lbs
98 30		8 200	⚠ 1000 V 3/8	6 1/2 165	3/8	0.91
98 40		8 200	⚠ 1000 V 1/2	6 1/2 165	1/2	1.34

Reversible Ratchets

with driving square 3/8" or 1/2"

IEC 60900 DIN EN 60900

98

- > for use with sockets
- > reversible for clockwise and counterclockwise directions
- > extremely smooth action
- > for quick, easy and secure locking of attached sockets
- > chrome vanadium steel; forged



98 31

⚠ 1000 V $\frac{3}{8}$ "

Product Number	Packaging	↔ Inch mm		Square drive Inch	⚖ lbs
98 31		7 1/2 190	⚠ 1000 V $\frac{3}{8}$ "	3/8	0.71
98 41		10 7/16 265	⚠ 1000 V $\frac{1}{2}$ "	1/2	1.38

Extension Bars

with internal and external driving square 3/8" or 1/2"

IEC 60900 DIN EN 60900

98

- > for use with sockets
- > with internal and external square
- > for quick, easy and secure locking of attached sockets
- > chrome vanadium steel, forged



98 35 125

⚠ 1000 V $\frac{3}{8}$ " $\frac{3}{8}$ "



98 45 250

⚠ 1000 V $\frac{1}{2}$ " $\frac{1}{2}$ "

Product Number	Packaging	↔ Inch mm		Square drive Inch	⚖ lbs
98 35 125		5 125	⚠ 1000 V $\frac{3}{8}$ " $\frac{3}{8}$ "	3/8	0.33
98 35 250		10 250		3/8	0.62
98 45 125		5 125	⚠ 1000 V $\frac{1}{2}$ " $\frac{1}{2}$ "	1/2	0.57
98 45 250		10 250		1/2	1.08

Hexagon Sockets for hexagonal screws

for internal square 3/8" or 1/2"

IEC 60900 DIN EN 60900

98



98 37 17
⚡ 1000 V ○ 3/8" ○



98 47 17
⚡ 1000 V ○ 1/2" ○



Product Number	Packaging	↔ Inch mm		Width across flats S Inch mm	dia. of effective tool side d max. Inch mm	Square drive Inch	⚖ lbs
98 37 10		1 21/32 42	⚡ 1000 V ○ 3/8" ○	25/64 10.0	47/64 18.7	3/8	0.07
98 37 11		1 21/32 43		7/16 11.0	25/32 20.0	3/8	0.08
98 37 12		1 3/4 44		15/32 12.0	53/64 21.2	3/8	0.09
98 37 13		1 49/64 45		1/2 13.0	57/64 22.5	3/8	0.09
98 37 14		1 13/16 46		35/64 14.0	15/16 23.7	3/8	0.10
98 37 16		1 13/16 46		5/8 16.0	1 1/32 26.2	3/8	0.12
98 37 17		1 13/16 46		43/64 17.0	1 5/64 27.5	3/8	0.12
98 37 19		1 59/64 49		3/4 19.0	1 3/16 30.0	3/8	0.14
98 47 10		2 1/8 54		⚡ 1000 V ○ 1/2" ○	25/64 10.0	3/4 19.5	1/2
98 47 11		2 1/8 54	7/16 11.0		13/16 20.7	1/2	0.15
98 47 12		2 11/64 55	15/32 12.0		29/32 23.0	1/2	0.14
98 47 13		2 11/64 55	1/2 13.0		29/32 23.2	1/2	0.15
98 47 14		2 11/64 55	35/64 14.0		31/32 24.5	1/2	0.16
98 47 16		2 11/64 55	5/8 16.0		1 1/16 26.9	1/2	0.19
98 47 17		2 11/64 55	43/64 17.0		1 7/64 28.2	1/2	0.18
98 47 18		2 11/64 55	45/64 18.0		1 9/64 29.0	1/2	0.19
98 47 19		2 1/8 54	3/4 19.0		1 13/64 30.7	1/2	0.22
98 47 22		2 9/32 58	55/64 22.0		1 23/64 34.5	1/2	0.28
98 47 24		2 13/32 61	15/16 24.0		1 29/64 37.0	1/2	0.34
98 47 27		2 31/64 63	1 1/16 27.0	1 19/32 41.0	1/2	0.42	

Sockets

for internal square 3/8" or 1/2"
IEC 60900 DIN EN 60900

98

- > 12 points of contact
- > for imperial hexagonal head screws
- > chrome plated
- > chrome vanadium steel



98 47 1/2"
1000 V  



Product Number	Packaging	↔ Inch mm		Width across flats S Inch	dia. of effective tool side d max. Inch	Square drive Inch	⚖ lbs
98 37 1/2"		1 49/64 45	1000 V  	1/2	57/64	3/8	0.09
98 37 3/4"		1 59/64 49		3/4	1 3/16	3/8	0.14
98 37 3/8"		1 21/32 42		3/8	47/64	3/8	0.07
98 37 5/16"		1 21/32 42		5/16	5/8	3/8	0.07
98 37 5/8"		1 13/16 46		5/8	1 1/32	3/8	0.11
98 37 7/16"		1 11/16 43		7/16	25/32	3/8	0.08
98 37 9/16"		1 27/32 47		9/16	15/16	3/8	0.09
98 47 1"		2 13/32 61	1000 V  	1	1 19/32	1/2	0.38
98 47 1/2"		2 11/64 55		1/2	29/32	1/2	0.15
98 47 11/16"		2 11/64 55		11/16	1 7/64	1/2	0.18
98 47 3/4"		2 11/64 55		3/4	1 13/64	1/2	0.19
98 47 5/8"		2 11/64 55		5/8	1 1/16	1/2	0.19
98 47 7/8"		2 9/32 58		7/8	1 23/64	1/2	0.26
98 47 9/16"		2 11/64 55		9/16	31/32	1/2	0.16

Hexagon Sockets for hexagon socket screws

for internal square 3/8" or 1/2"

DIN 7422 IEC 60900 DIN EN 60900

98



98 39 06

⚡ 1000 V



- > for metric internal hexagonal socket screws
- > chrome plated
- > special tool steel

Product Number	Packaging	↔ Inch mm		Width across flats S mm	Length of non-insulated blade ± 2 Inch mm	Square drive Inch	⚖ lbs
98 39 05		3 75	⚡ 1000 V	5.0	23/64 9	3/8	0.12
98 39 06		3 75		6.0	25/64 10	3/8	0.15
98 39 08		3 75		8.0	7/16 11	3/8	0.20
98 49 05		3 75	⚡ 1000 V	5.0	23/64 9	1/2	0.16
98 49 06		3 75		6.0	25/64 10	1/2	0.18
98 49 08		3 75		8.0	7/16 11	1/2	0.21

Reversible Ratchet

with driving square 1/2"

ISO 3315 IEC 60900 DIN EN 60900

98

4



98 42

⚡ 1000 V 1/2"

- > reversible for clockwise and counterclockwise directions
- > very reliable coupling of sockets with bolt-activated locking system
- > chrome vanadium steel

Product Number	Packaging	↔ Inch mm		Square drive Inch	⚖ lbs
98 42		10 1/2 265	⚡ 1000 V 1/2"	1/2	1.27

Torque Wrench

with driving square, reversible

IEC 60900 DIN EN 60900 DIN EN ISO 6789

98



98 43 50

⚡ 1000 V

- > reversible for tightening of left handed threads
- > lockable torque adjustment
- > very reliable coupling of sockets with bolt-activated locking system
- > transparent insulated scale range
- > calibration certificate included
- > chrome vanadium steel

Transparent insulated scale range

Product Number	Packaging	↔ Inch mm		Range of application	Square drive Inch	⚖ lbs
98 33 25		11 27/64 290	⚡ 1000 V	5 - 25 Nm	3/8	2.17
98 33 50		15 385	⚡ 1000 V	5 - 50 Nm	3/8	2.71
98 43 50		15 385	⚡ 1000 V	5 - 50 Nm	1/2	2.71

Cable Knives

IEC 60900 DIN EN 60900

98
5

- > ergonomically improved handle shape with comfortable slip guard
- > secure grip due to slip-proof soft components
- > thumb recess and "finger hook" at the end of the handle ensure a good transmission of force when the blade is pulled
- > solid, fixed straight blade
- > transparent protective cap
- > blade: special tool steel, oil-hardened

98 54

Back of the blade is plastic coated to avoid short circuit



98 52

⚡ 1000 V  



98 54

⚡ 1000 V  

Product Number	Packaging	↔ Inch mm		Handle	Blade length Inch mm	⚖ lbs
98 52		7 1/2 190	⚡ 1000 V  	insulated multi-component handle, VDE-tested	1 31/32 50	0.18
98 54	X	7 1/2 190	⚡ 1000 V  	insulated multi-component handle, VDE-tested	1 31/32 50	0.18

Dismantling Knives

IEC 60900 DIN EN 60900

98
5

- > ergonomically improved handle shape with comfortable slip guard
- > secure grip due to slip-proof soft components
- > thumb recess and "finger hook" at the end of the handle ensure a good transmission of force when the blade is pulled
- > transparent protective cap

98 53 03

Solid, fixed hook blade; suitable for round cables; blade: special tool steel, oil-hardened

98 53 13

Narrow, fixed hook blade, sickle shaped; suitable for sector cables; blade: special tool steel, oil-hardened

98 55

Solid, fixed hook blade, sickle shaped; with guide shoe at the blade point: no damage of the conductor insulation; blade: surgical steel, stainless, air-hardened



98 53 03

⚡ 1000 V  



98 53 13

⚡ 1000 V  



98 55

⚡ 1000 V  



Guide shoe 98 55

Product Number	Packaging	↔ Inch mm		Handle	Blade length Inch mm	Radius Inch mm	⚖ lbs
98 53 03		6 3/4 170	⚡ 1000 V  	insulated multi-component handle, VDE-tested	1 7/64 28	9/32 7	0.14
98 53 13		7 1/2 190	⚡ 1000 V  	insulated multi-component handle, VDE-tested	1 31/32 50	1 37/64 40	0.14
98 55	X	7 1/4 180	⚡ 1000 V  	insulated multi-component handle, VDE-tested	1 1/2 38	59/64 23.5	0.15

Cable Knife

with replaceable blade

IEC 60900 DIN EN 60900

98
5

- > straight blade with special grinding; replaceable
- > with hinged blade guard, integrated in the handle, captive
- > back of the blade is plastic coated to avoid short circuit
- > ergonomically shaped safety handle
- > blade: surgical steel, stainless, air-hardened



98 56

⚡ 1000 V  

Product Number	Packaging	↔ Inch mm		Blade length Inch mm	⚖ lbs
98 56		7 1/2 190	⚡ 1000 V  	1 31/32 50	0.14
98 56 09	Spare Blade for 98 56				

Flat Nose Pliers of plastic

insulating

IEC 60900 DIN EN 60900 ASTM F1505

98
6

- > full insulation reduces risk of short circuit
- > for meter assembly and meter blocking
- > class C; range of use up to -40°C/-40°F
- > plastic material, fiberglass-reinforced
- > handles with soft plastic zone for a better grip



98 62 01

⚡ 1000 V     

Product Number	Packaging	↔ Inch mm		⚖ lbs
98 62 01		7 1/4 180	⚡ 1000 V     	0.26

KNIPEX presents high-quality and sturdy plastic pliers featuring protection against bridging for working on live parts up to AC 1000V and DC 1500V.

These solid plastic pliers do not act on magnetic fields and are fully spark free. They are also excellent for use in chemically aggressive environments.

Snipe Nose Pliers of plastic

insulating

IEC 60900 DIN EN 60900 ASTM F1505

98
6

- > full insulation reduces risk of short circuit
- > class C; range of use up to -40°C/-40°F
- > plastic material, fiberglass-reinforced
- > handles with soft plastic zone for better grip



98 62 02

⚡ 1000 V     

Product Number	Packaging	↔ Inch mm		⚖ lbs
98 62 02		8 3/4 220	⚡ 1000 V     	0.32



Insulating Mats

from rubber
DIN EN/IEC 61112

98
6

> for added protection when working live or close to live parts



98 67 05

⚡ 1000 V

Product Number	Packaging		Dimensions Inch mm	Thickness Inch mm	⚖ lbs
98 67 05			20 x 20 500 x 500	3/64 1.0	0.66
98 67 10		⚡ 1000 V	39 3/8 x 39 3/8 1000 x 1000	3/64 1.0	2.65

PUK® Junior Hacksaw

IEC 60900 DIN EN 60900

98
90

> saw blade for metal and wood with 25 teeth per inch, exchangeable



98 90

⚡ 1000 V

Product Number	Packaging	↔ Inch mm		Saw blade length Inch mm	⚖ lbs
98 90		9 1/2 240	⚡ 1000 V	6 150	0.41

Compact Tool Case

17 parts

with insulated tools for working on electrical installations

IEC 60900 DIN EN 60900

98

6

- > shock-resistant plastic case
- > containing a range of insulated KNIPEX tools for work on electrical installations
- > foam inserts with recesses for the tools
- > fixable partition wall
- > ext. dimensions (W x H x D):
14 11/64" x 4 21/64" x 12 13/64" (360 x 110 x 310 mm)



98 99 11
 1000V

Product Number	Packaging		Set contents	Units	 lbs
98 99 11	X		Compact Tool Case 17 parts	-	8.73
		  	03 07 200 Combination Pliers	1	-
		 	70 07 160 Diagonal Cutter	1	-
			98 20 35	1	-
		  	98 20 40 Screwdrivers for slotted screws	1	-
			98 20 55	1	-
		  	98 24 00 Screwdriver for cross recessed screws, Phillips®	1	-
		 	98 42 Reversible Ratchet, with driving square 1/2"	1	-
		  	98 45 125 Extension Bar, with internal/external square 1/2"	1	-
			98 45 250	1	-
			98 47 10	1	-
			98 47 11	1	-
			98 47 12	1	-
		  	98 47 13 Hexagon Socket for hexagonal screws, with internal square 1/2"	1	-
			98 47 14	1	-
			98 47 17	1	-
			98 47 19	1	-
		 	98 52 Cable Knife	1	-

Safety Compact Tool Case

10 parts

IEC 60900 DIN EN 60900

98

99

- > shock-resistant plastic case
- > foam insert with precise recesses for holding the pliers
- > equipped with a range of custom insulated KNIPEX tools for work on electrical systems
- > all tools 100% tested and meet ASTM F1505 and IEC 60900 requirements
- > ext. dimensions (W x H x D):
14 31/32 x 3 11/32 x 10 15/64" (380 x 85 x 260 mm)
- > int. dimensions (W x H x D):
13 3/16 x 2 3/4 x 93/64" (335 x 70 x 230 mm)



98 99 11 53
⚠ 1000 V



98 99 11 54
⚠ 1000 V



98 99 11 55
⚠ 1000 V



98 99 11 56
⚠ 1000 V

Product Number	Packaging			Set contents	Units	lbs 
98 99 11 53	X	-	Safety compact tool case with insulated tools (3/8") for working on electrical systems	-	-	3.64
		 1000 V 	98 31	Reversible Ratchet, with external square 3/8"	1	-
		 1000 V  	98 35 125	Extension Bar, with internal/external square 3/8"	1	-
			98 35 250		1	-
		 1000 V  	98 37 1/2"	12-Point Socket, with internal square 3/8"	1	-
			98 37 3/4"		1	-
			98 37 3/8"		1	-
			98 37 5/16"		1	-
			98 37 5/8"		1	-
			98 37 7/16"		1	-
			98 37 9/16"		1	-
98 99 11 54	X	-	Safety compact tool case with insulated tools (3/8") for working on electrical systems	-	-	3.64
		 1000 V 	98 31	Reversible Ratchet, with external square 3/8"	1	-
		 1000 V  	98 35 125	Extension Bar, with internal/external square 3/8"	1	-
			98 35 250		1	-
		 1000 V  	98 37 10	Hexagon socket for hexagonal screws, with internal square 3/8"	1	-
			98 37 11		1	-
			98 37 12		1	-
			98 37 13		1	-
			98 37 14		1	-
			98 37 17		1	-
			98 37 19		1	-
98 99 11 55	X	-	Safety compact tool case with insulated tools (1/2") for working on electrical systems	-	-	5.62
		 1000 V 	98 41	Reversible Ratchet, with driving square 1/2"	1	-
		 1000 V  	98 45 125	Extension Bar, with internal/external square 1/2"	1	-
			98 45 250		1	-
		 1000 V  	98 47 1"	12-Point Socket, with internal square 1/2"	1	-
			98 47 1/2"		1	-
			98 47 11/16"		1	-
			98 47 3/4"		1	-
			98 47 5/8"		1	-
			98 47 7/8"		1	-
		98 47 9/16"	1	-		
98 99 11 56	X	-	Safety compact tool case with insulated tools (1/2") for working on electrical systems	-	-	5.62
		 1000 V 	98 41	Reversible Ratchet, with driving square 1/2"	1	-
		 1000 V  	98 45 125	Extension Bar, with internal/external square 1/2"	1	-
			98 45 250		1	-
		 1000 V  	98 47 13	Hexagon socket for hexagonal screws, with internal square 1/2"	1	-
			98 47 14		1	-
			98 47 17		1	-
			98 47 19		1	-
			98 47 22		1	-
			98 47 24		1	-
		98 47 27	1	-		

Standard Tool Case

26 parts

with insulated tools for working on electrical installations
IEC 60900 DIN EN 60900

98
9

- > containing a range of insulated KNIPEX tools for work on electrical installations
- > shock-resistant plastic case
- > foam inserts with recesses for the tools
- > fixable partition wall
- > ext. dimensions (W x H x D):
17 21/64 x 4 1/8 x 15 5/32" (440 x 105 x 385 mm)

98 99 12
⚡ 1000V



Product Number	Packaging		Set contents	Units	lbs
98 99 12	X	-	Standard Tool Case 26 parts	-	12.20
		⚡ 1000V ⚡ ⚡ ⚡ ⚡	03 07 200 Combination Pliers	1	-
		⚡ 1000V ⚡ ⚡ ⚡	70 07 160 Diagonal Cutter	1	-
			98 00 10	1	-
			98 00 11	1	-
			98 00 12	1	-
		⚡ 1000V ○	98 00 13 Open End Wrench	1	-
			98 00 14	1	-
			98 00 17	1	-
			98 00 19	1	-
		⚡ 1000V ⚡ ⚡	98 53 03 Dismantling Knife for round cables	1	-
			98 20 25	1	-
		⚡ 1000V ⚡ ⚡ ⚡	98 20 35 Screwdrivers for slotted screws	1	-
			98 20 40	1	-
			98 20 55	1	-
			98 24 00	1	-
		⚡ 1000V ⚡ ⚡ ⚡	98 24 01 Screwdriver for cross recessed screws, Phillips®	1	-
			98 24 02	1	-
		⚡ 1000V 1/2"	98 40 T-Handle Drive, with driving square 1/2"	1	-
			98 47 10	1	-
			98 47 11	1	-
			98 47 12	1	-
		⚡ 1000V ○ ⚡	98 47 13 Hexagon Socket for hexagonal screws, with internal square 1/2"	1	-
			98 47 14	1	-
			98 47 17	1	-
			98 47 19	1	-
		⚡ 1000V ⚡ ⚡	98 52 Cable Knife	1	-

Tool Roll

15 parts
IEC 60900 DIN EN 60900

98
9

- > tool roll made of hard-wearing polyester fabric
- > with sturdy, adjustable snap-closure
- > containing a range of insulated KNIPEX tools for work on electrical installations



Product Number	Packaging			Set contents	Units	lbs
98 99 13	X	-		Tool Roll 15 parts	-	5.41
		⚠ 1000 V	03 07 200	Combination Pliers	1	-
		⚠ 1000 V	11 07 160	Diagonal Cutter	1	-
		⚠ 1000 V	26 17 200	Snipe Nose Side Cutting Pliers, (Stork Beak Pliers)	1	-
		⚠ 1000 V	70 07 160	Diagonal Cutter	1	-
		⚠ 1000 V	95 17 200	Cable Shears, with twin cutting edge	1	-
			98 00 10	Open End Wrench	1	-
			98 00 13		1	-
		⚠ 1000 V	98 00 14		1	-
			98 00 17		1	-
			98 00 19		1	-
			98 20 25	Screwdrivers for slotted screws	1	-
		⚠ 1000 V	98 20 40		1	-
			98 20 55		1	-
			98 20 65		1	-
		⚠ 1000 V	98 52	Cable Knife	1	-

Safety Tool Rolls

8 parts

98
99

- > plastic tool roll
- > equipped with open end wrenches for work on electrical systems
- > all tools 100% tested and meet ASTM F1505 and IEC 60900 requirements
- > dimensions, rolled out (W x H x D):
16 9/64 x 63/64 x 11 13/32" (410 x 25 x 290 mm)
- > dimensions, rolled up (W x H x D):
2 61/64 x 2 61/64 x 11 13/32" (75 x 75 x 290 mm)



Product Number	Packaging			Set contents	Units	lbs
98 99 13 54		-	Safety Toll Roll 8 parts	-	-	1.71
		⚠ 1000 V	98 00 1/4"	Open End Wrench	1	-
			98 00 5/16"		1	-
			98 00 3/8"		1	-
			98 00 7/16"		1	-
			98 00 1/2"		1	-
			98 00 9/16"		1	-
			98 00 5/8"		1	-
			98 00 3/4"		1	-
98 99 13 55			Safety Toll Roll 8 parts		-	2.54
		⚠ 1000 V	98 00 24	Open End Wrench	1	-
			98 00 22		1	-
			98 00 19		1	-
			98 00 17		1	-
			98 00 14		1	-
			98 00 13		1	-
			98 00 10		1	-
			98 00 08		1	-

Universal Tool Case

46 parts

IEC 60900 DIN EN 60900

98
9

98 99 14

- > hard-wearing case made of ABS material, red; containing a range of KNIPEX tools for work on electrical installations, tested according to IEC 60900, as well as additional protective covers, clamps and gloves
- > sturdy aluminum frame with D-shape rings for belt and fix, sturdy center board with multipurpose push-in facilities by elastic loops and 12 small pockets
- > comfortable handle and mounting device for a "trolley" embedded in the bottom (available for ordering ref. 00 21 40 T)
- > metal hinges
- > 66 pounds (30 kg) maximum load
- > can be opened on one or both sides; bottom tray and cover can be opened independently
- > stands securely in any opening position due to lid-holders and hinge mechanisms on both sides, that register in a position of 45° and 90°
- > 3-digit lock and 2 clamp-locks for fixation of the cover
- > removable document compartment and removable tool board, with 13 push-in compartments on one side
- > 2 tilting locks to fix the bottom
- > base tray height 2 9/32" (58 mm), can be subdivided by flexible inserts; cover plate with 6 large push-in compartments, can be fixed by push-button
- > ext. dimensions (W x H x D):
19 19/64 x 10 3/64 x 16 9/64" (490 x 220 x 410 mm)
- > int. dimensions (W x H x D):
17 33/64 x (4 1/8 + 4 1/8) 13 25/32" (445 x (105 + 105) x 350 mm)

00 21 40 T

- > telescopic handle for rolling transport
- > applicable for cases: 00 21 40 LE Tool Case "BIG Twin" and 98 99 14 Universal Tool Case
- > height adjustable handle with catch
- > integrated mechanism for fixation to the case, for rapid assembly and removal
- > with 2 smooth running rolls
- > dimensions: 60 x 245 x 400 (1,000) mm (extended)



98 99 14
⚡ 1000V



00 21 40 T



Product Number	Packaging		Set contents	Units	⚖ lbs	
98 99 14	X	-	Universal Tool Case 46 parts	-	35.83	
		70 07 160	Diagonal Cutter	1	-	
		 1000 V 	Alligator® Water Pump Pliers	1	-	
		98 00 10	Open End Wrenches	1	-	
		98 00 13		1	-	
		98 00 14		1	-	
		98 00 17		1	-	
		98 00 19		1	-	
		98 00 22		1	-	
		 1000 V 	Box Wrenches	98 01 10	1	-
		98 01 13		1	-	
		98 01 14		1	-	
		98 01 17		1	-	
		98 01 19		1	-	
		98 01 22		1	-	
		 1000 V 	98 67 05	Insulating Mat, from rubber	3	-
		 1000 V 	98 40	T-Handle Drive, with driving square 1/2"	1	-
			98 42	Reversible Ratchet, with driving square 1/2"	1	-
		 1000 V  	98 45 125	Extension Bar, with internal/external square 1/2"	1	-
			98 45 250		1	-
		 1000 V  	98 47 10	Hexagon socket for hexagonal screws, with internal square 1/2"	1	-
			98 47 11		1	-
			98 47 12		1	-
			98 47 13		1	-
			98 47 14		1	-
			98 47 17		1	-
			98 47 19		1	-
			98 47 22		1	-
		 1000 V 	98 52	Cable Knife	1	-
		 1000 V 	98 53 03	Dismantling Knife for round cables	1	-
		 1000 V 	98 64 02	Insulating Plastic Clamp, from plastic	6	-
		 1000 V	98 65 40	Electricians' Gloves	1	-
98 99 14 LE			Universal Tool Case empty	-	290.5 8235	
00 21 40 T			Trolley for rolling case transport	-	42.3 1200	



9K 98 98 20 US



9K 98 98 21 US



9K 98 98 22 US



9K 98 98 25 US



9K 98 98 26 US

Product Number	Packaging		Set contents	Units	lbs	
9K 98 98 20 US		⚠ 1000V ○	5 Pc Automotive Pliers /Screwdriver Tool Set-1,000V	-	2.90	
			74 08 250 US	10" High Leverage Diagonal Cutters-1,000V Insulated	1	-
			88 08 250 US	10" Alligator® Pliers-1,000V Insulated	1	-
			9T 53704	MAXXPRO 1,000V Insulated 4" Slotted 5/32" Tip	1	-
			9T 53706	MAXXPRO 1,000V Insulated 6" Slotted 1/4" Tip	1	-
			9T 53712	MAXXPRO 1,000V Insulated 4" Phillips #2	1	-
9K 98 98 21 US		⚠ 1000V ○	5 Pc Pliers/Screwdriver Tool Set-1,000V Insulated	-	2.62	
			74 08 200 US	8" High Leverage Diagonal Cutters-1,000V Insulated	1	-
			02 08 225 US	9" High Leverage Combination Pliers-1,000V Insulated	1	-
			9T 53705	MAXXPRO 1,000V Insulated 5" Slotted 7/32" Tip	1	-
			9T 53712	MAXXPRO 1,000V Insulated 4" Phillips #2	1	-
			9T 54812	MAXXPRO 1,000V Insulated 5" Square #2	1	-
9K 98 98 22 US		⚠ 1000V ○	5 Pc Pliers/Screwdriver Tool Set-1,000V Insulated	-	4.35	
			74 08 250 US	10" High Leverage Diagonal Cutters-1,000V Insulated	1	-
			09 08 240 US	9-1/4" High Leverage Lineman New England Head-1,000V Insulated	1	-
			9T 53705	MAXXPRO 1,000V Insulated 5" Slotted 7/32" Tip	1	-
			9T 53712	MAXXPRO 1,000V Insulated 4" Phillips #2	1	-
			9T 54812	MAXXPRO 1,000V Insulated 5" Square #2	1	-
9K 98 98 25 US		⚠ 1000V ○	7 Pc Pliers/Screwdriver Tool Set-1,000V, Nylon Pouch	-	4.35	
			74 08 200 US	8" High Leverage Diagonal Cutters-1,000V Insulated	1	-
			88 08 250 US	10" Alligator® Pliers-1,000V Insulated	1	-
			26 18 200 US	8" Long Nose Pliers w/ Cutter-1,000V Insulated	1	-
			02 08 225 US	9" High Leverage Combination Pliers-1,000V Insulated	1	-
			9T 53705	MAXXPRO 1,000V Insulated 5" Slotted 7/32" Tip	1	-
			9T 53712	MAXXPRO 1,000V Insulated 4" Phillips #2	1	-
			9T 54812	MAXXPRO 1,000V Insulated 5" Square #2	1	-
9K 98 98 26 US		⚠ 1000V ○	7 Pc Pliers/Screwdriver Tool Set-1,000V, Nylon Pouch	-	4.45	
			09 08 240 US	9-1/4" High Leverage Lineman New England Head-1,000V Insulated	1	-
			26 18 200 US	8" Long Nose Pliers w/ Cutter-1,000V Insulated	1	-
			88 08 250 US	10" Alligator® Pliers-1,000V Insulated	1	-
			74 08 250 US	10" High Leverage Diagonal Cutters-1,000V Insulated	1	-
			9T 53705	MAXXPRO 1,000V Insulated 5" Slotted 7/32" Tip	1	-
			9T 53712	MAXXPRO 1,000V Insulated 4" Phillips #2	1	-
			9T 54812	MAXXPRO 1,000V Insulated 5" Square #2	1	-



9K 98 98 27 US



9K 98 98 30 US



9K 98 98 31 US

Product Number	Packaging		Set contents	Units	lbs	
9K 98 98 27 US			7 Pc Pliers/Screwdriver Tool Set-1,000V, Nylon Pouch	-	4.33	
		⚠ 1000V ○	26 18 200 US	10" High Leverage Diagonal Cutters-1,000V Insulated	1	-
			74 08 200 US	10" Alligator® Pliers-1,000V Insulated	1	-
			02 08 225 US	MAXXPRO 1,000V Insulated 4" Slotted 5/32" Tip	1	-
			88 08 250 US	MAXXPRO 1,000V Insulated 6" Slotted 1/4" Tip	1	-
			9T 53704	MAXXPRO 1,000V Insulated 4" Phillips #2	1	-
			9T 53706	MAXXPRO 1,000V Insulated 6" Slotted 1/4" Tip	1	-
			9T 53712	MAXXPRO 1,000V Insulated 4" Phillips #2	1	-
9K 98 98 30 US			10 Pc Pliers/Screwdriver Tool Set-1,000V, Hard Case	-	6.54	
		⚠ 1000V ○	02 08 225 US	9" High Leverage Combination Pliers-1,000V Insulated	1	-
			74 08 200 US	8" High Leverage Diagonal Cutters-1,000V Insulated	1	-
			95 18 165 US	6-1/2" Cable Shears-1,000V Insulated	1	-
			26 18 200 US	8" Long Nose Pliers w/ Cutter-1,000V Insulated	1	-
			88 08 250 US	10" Alligator® Pliers-1,000V Insulated	1	-
			9T 53704	MAXXPRO 1,000V Insulated 4" Slotted 5/32" Tip	1	-
			9T 53706	MAXXPRO 1,000V Insulated 6" Slotted 1/4" Tip	1	-
			9T 53711	MAXXPRO 1,000V Insulated 3-1/4" Phillips #1	1	-
			9T 53712	MAXXPRO 1,000V Insulated 4" Phillips #2	1	-
			9T 54812	MAXXPRO 1,000V Insulated 5" Square #2	1	-
9K 98 98 31 US			10 Pc Pliers/Screwdriver Tool Set-1,000V, Hard Case	-	6.90	
		⚠ 1000V ○	02 08 225 US	10" High Leverage Diagonal Cutters-1,000V Insulated	1	-
			74 08 200 US	6-1/4" Cable Shears-1,000V Insulated	1	-
			95 18 165 US	9-1/4" High Leverage Lineman New England Head-1,000V Insulated	1	-
			26 18 200 US	8" Long Nose Pliers w/ Cutter-1,000V Insulated	1	-
			88 08 250 US	10" Alligator® Pliers-1,000V Insulated	1	-
			9T 53704	MAXXPRO 1,000V Insulated 4" Slotted 5/32" Tip	1	-
			9T 53706	MAXXPRO 1,000V Insulated 6" Slotted 1/4" Tip	1	-
			9T 53711	MAXXPRO 1,000V Insulated 3-1/4" Phillips #1	1	-
			9T 53712	MAXXPRO 1,000V Insulated 4" Phillips #2	1	-
			9T 54812	MAXXPRO 1,000V Insulated 5" Square #2	1	-

00 11 01	192	03 01 200	28	13 81 8	45	28 21 200	56	38 81 200 B	69
00 11 02	193	03 01 250	28	13 82 8	45	28 71 280	57	38 91 200	69
00 11 03	193	03 02 160	28	13 82 8 T BKA	45, 210	28 81 280	57	40 04 180	70
00 11 04	193	03 02 180	28	13 88 8 US	45, 216	29 11 160	58	40 04 250	70
00 11 06	194	03 02 200	28	15 11 120	46	29 21 160	58	40 14 250	70
00 11 06 V01	194	03 08 160 SBA	28, 214	15 19 005	46	30 11 140	59	41 04 180	71
00 11 V50	195	03 08 200 SBA	28, 214	15 19 006	46	30 11 160	59	41 04 250	71
00 19 41	196	08 21 145	29	15 19 008	46	30 11 190	59	41 04 300	71
00 19 55 S4	196	08 22 145	29	15 19 010	46	30 16 160	59, 218	41 14 250	71
00 19 55 S5	196	08 22 145 T BKA	29, 210	15 51 160	46	30 21 140	59	41 24 225	71
00 19 56	197	08 28 145 US	29, 215	15 61 160	46	30 21 160	59	41 34 165	71
00 19 56 LE	197	09 01 240	31	15 81 160	46	30 21 190	59	41 44 200	71
00 19 57	197	09 02 240	31	16 20 16 SB	47	30 31 160	59	42 14 280	72
00 19 58 V01	197	09 02 240 T BKA	31, 210	16 20 165 SB	47	30 36 160	59, 218	42 24 280	72
00 19 58 V02	197	09 08 240 US	31, 215	16 29 165	47	30 41 160	60	42 34 280	72
00 19 72 LE	198, 204	09 11 240	31	16 30 135 SB	47	31 11 160	60	42 44 280	72
00 20 01 V15	199	09 12 240	31	16 39 135	47	31 21 160	60	44 10 J5	73
00 20 01 V16	199	09 12 240 T BKA	31, 210	16 40 150	48	32 11 135	61	44 10 J6	73
00 20 01 V17	199	10 98 I220	32	16 49 150	48	32 21 135	61	44 11 J0	74
00 20 03 SB	200	10 99 I220	32	16 60 05 SB	48	32 31 135	61	44 11 J1	74
00 20 03 V02	200	11 01 160	33	16 65 125 SB	49	33 01 160	61	44 11 J2	74
00 20 04 SB	200	11 02 160	33	16 80 125 SB	49	34 12 130	64	44 11 J3	74
00 20 04 V01	200	11 08 160 SBA	33, 215	16 85 125 SB	49	34 12 130 ESD	64	44 11 J4	74
00 20 05 US	201	11 82 130	34	16 95 01 SB	50	34 22 130	64	44 19 J5	73
00 20 06 US1	201	11 92 140	34	16 95 02 SB	50	34 22 130 ESD	64	44 19 J6	73
00 20 06 US2	201	12 11 180	35	19 01 130	51	34 32 130	64	44 20 J51	73
00 20 07 US1	201	12 12 02	37	20 01 125	51	34 32 130 ESD	64	44 20 J61	73
00 20 08 US1	201	12 12 06	37	20 01 140	51	34 42 130	64	44 21 J01	74
00 20 08 US2	201	12 12 10	37	20 01 160	51	34 42 130 ESD	64	44 21 J11	74
00 20 09 V01	202	12 12 11	37	20 01 180	51	34 52 130	64	44 21 J21	74
00 20 10	202	12 12 13	37	20 02 140	51	34 52 130 ESD	64	44 21 J31	74
00 20 11	202	12 12 14	37	20 02 160	51	35 11 115	65	44 21 J41	74
00 20 16	203	12 19 180	35	20 06 160	51, 216	35 12 115	65	44 29 J51	73
00 20 16 P	203	12 21 180	35	22 01 125	52	35 12 115 ESD	66	44 29 J61	73
00 20 16 P ESD	203	12 29 180	35	22 01 140	52	35 21 115	65	44 31 J02	74
00 20 17	203	12 40 200	38	22 01 160	52	35 22 115	65	44 31 J12	74
00 20 18	203	12 42 195	39	22 02 140	52	35 22 115 ESD	66	44 31 J22	74
00 20 18 ESD	203	12 49 01	38	22 02 160	52	35 31 115	65	44 31 J32	74
00 20 72 V01	204	12 49 02	38	22 08 160 SBA	52, 216	35 32 115	65	44 31 J42	74
00 20 72 V02	204	12 49 03	38	23 01 140	52	35 32 115 ESD	66	45 10 170	80
00 21 40 T	247	12 49 21	39	25 01 125	53	35 41 115	65	45 21 200	80
00 21 41 LE	205	12 49 23	39	25 01 140	53	35 42 115	65	46 10 100	81
00 31 20 V02	204	12 50 200	38	25 01 160	53	35 42 115 ESD	66	46 10 A5	73
00 31 V01 US	204	12 59 01	38	25 02 140	53	35 52 145	65	46 10 A6	73
00 50 01 T BK	211	12 59 02	38	25 02 160	53	35 62 145	65	46 11 A0	75
00 50 02 T BK	211	12 62 180	40	25 08 160 SBA	53, 217	35 72 145	65	46 11 A1	75
00 50 03 T BK	211	12 64 180	40	25 21 160	53	35 82 145	65	46 11 A2	75
00 50 04 T BK	211	12 69 21	40	26 11 200	54	36 12 130	67	46 11 A3	75
02 01 180	27	12 69 23	40	26 11 200 S1	54	36 22 125	67	46 11 A4	75
02 01 200	27	12 69 31	40	26 12 200	54	36 32 125	67	46 11 G0	80
02 01 225	27	12 74 180 SB	41	26 12 200 T BKA	54, 210	37 11 125	68	46 11 G1	80
02 02 180	27	12 79 31	41	26 16 200 T	211	37 21 125	68	46 11 G2	80
02 02 200	27	12 80 040 SB	41	26 18 200 US	55, 217	37 31 125	68	46 11 G3	80
02 02 225	27	12 80 100 SB	41	26 21 200	54	37 41 125	68	46 11 G4	80
02 02 225 T BKA	27, 210	13 01 160	42	26 22 200	54	38 11 200	69	46 19 A5	73
02 08 200 US	27, 214	13 01 614	42	26 22 200 T BKA	54, 210	38 21 200	69	46 19 A6	73
02 08 225 US	27, 214	13 02 160	42	26 26 200 T	211	38 31 200	69	46 20 A51	73
03 01 140	28	13 02 614 T BKA	42, 210	26 28 200 SBA	55, 217	38 41 190	69	46 20 A61	73
03 01 160	28	13 42 165	43	27 01 160	56	38 71 200	69	46 21 A01	75
03 01 180	28	13 62 180	44	28 01 200	56	38 81 200 A	69	46 21 A11	75

46 21 A21	75	61 02 200	86	71 79 460	91	77 02 135 H ESD	113	81 19 250	122
46 21 A31	75	62 12 120	103	71 79 610	91	77 11 115	109	83 10 010	123
46 21 A41	75	64 01 115	105	71 79 760	91	77 12 115	109	83 10 015	123
46 29 A51	73	64 02 115	105	71 79 910	91	77 12 115 ESD	111	83 10 020	123
46 29 A61	73	64 02 115 ESD	106	71 82 950	92	77 21 115 N	109	83 10 030	123
46 31 A02	75	64 11 115	105	71 89 950	92	77 21 130	109	83 10 040	123
46 31 A12	75	64 12 115	105	72 01 140	95	77 22 115	109	83 20 010	123
46 31 A22	75	64 12 115 ESD	106	72 01 160	95	77 22 115 ESD	111	83 20 015	123
46 31 A32	75	64 22 115	105	72 01 180	95	77 22 130	109	83 20 020	123
46 31 A42	75	64 32 120	105	72 02 125	95	77 32 115	109	83 30 005	124
48 11 J0	76	64 32 120 ESD	106	72 11 160	95	77 32 115 ESD	111	83 30 010	124
48 11 J1	76	64 42 115	105	72 21 160	95	77 32 120 H	112	83 30 015	124
48 11 J2	76	64 52 115	105	72 51 160	95	77 32 120 H ESD	113	83 30 020	124
48 11 J3	76	64 62 120	105	72 62 200	96	77 41 115	109	83 30 030	124
48 11 J4	76	64 62 120 ESD	106	73 02 160	98	77 42 115	109	83 60 010	124
48 21 J01	76	64 72 120	105	73 06 160	98, 219	77 42 115 ESD	111	83 60 015	124
48 21 J11	76	67 01 140	86	73 71 180	99	77 42 130	109	83 61 010	124
48 21 J21	76	67 01 160	86	73 72 180 BK	99	77 52 115	109	83 61 015	124
48 21 J31	76	67 01 200	86	74 01 140	101	77 52 115 ESD	111	83 61 020	124
48 21 J41	76	68 01 160	87	74 01 160	101	77 72 115	109	84 11 200	125
48 31 J0	77	68 01 180	87	74 01 180	101	77 72 115 ESD	111	84 21 200	125
48 31 J1	77	68 01 200	87	74 01 200	101	78 03 125	115	85 01 250 US	125
48 31 J2	77	68 01 280	87	74 01 250	101	78 03 125 ESD	116	85 51 180 A	126
48 31 J3	77	69 01 130	87	74 02 140	101	78 03 140	117	85 51 180 C	127
48 41 J01	77	69 03 130	87	74 02 160	101	78 03 140 ESD	117	85 51 250 A	126
48 41 J11	77	70 01 110	93	74 02 180	101	78 13 125	115	85 51 250 AF	127
48 41 J21	77	70 01 125	93	74 02 200	101	78 13 125 ESD	116	85 51 250 C	127
48 41 J31	77	70 01 140	93	74 02 200 T BKA	101, 210	78 23 125	115	85 59 250 A	126
49 11 A0	78	70 01 160	94	74 02 250	101	78 31 125	115	85 59 250 A	127
49 11 A1	78	70 01 180	93	74 02 250 T BKA	101, 210	78 41 125	115	85 59 250 C	127
49 11 A2	78	70 02 125	93	74 06 200 T	211	78 61 125	115	86 01 250	129
49 11 A3	78	70 02 140	93	74 06 250 T	211	78 61 125 ESD	116	86 02 250	129
49 11 A4	78	70 02 160	94	74 08 200 US	101, 219	78 61 140	117	86 03 125	129
49 21 A01	78	70 02 180	93	74 08 250 US	101, 219	78 61 140 ESD	117	86 03 150	129
49 21 A11	78	70 06 160 T	211	74 12 160	101	78 71 125	115	86 03 180	129
49 21 A21	78	70 06 180 T	211	74 12 180	101	78 71 125 ESD	116	86 03 250	129
49 21 A31	78	70 08 160 SBA	94, 218	74 21 180	101	78 81 125	115	86 03 300	129
49 21 A41	78	70 08 180 SBA	93, 218	74 21 200	101	78 91 125	115	86 03 400 US	130
49 31 A0	79	70 11 110	93	74 21 250	101	79 02 120	119	86 05 150	129
49 31 A1	79	70 26 160	94, 218	74 22 200	101	79 02 120 ESD	121	86 05 180	129
49 31 A2	79	71 01 160	88	74 22 200 T BKA	101, 210	79 02 125	119	86 05 180 T BKA	129, 210
49 31 A3	79	71 01 200	88	74 22 250	101	79 02 125 ESD	121	86 05 250	129
49 41 A01	79	71 01 200 R	90	74 22 250 T BKA	210	79 12 125	119	86 05 250 T BKA	129, 210
49 41 A11	79	71 01 250	90	74 91 250	102	79 12 125 ESD	121	86 06 250 US	129, 220
49 41 A21	79	71 02 200	88	75 02 125	107	79 22 120	119	86 43 250 US	129
49 41 A31	79	71 02 200 T BKA	88, 210	75 12 125	107	79 22 120 ESD	121	87 01 125	133
50 00 160	82	71 12 200	88	75 22 125	107	79 22 125	119	87 01 150	133
50 00 180	82	71 21 200	89	75 52 125	107	79 22 125 ESD	121	87 01 180	133
50 00 210	82	71 22 200	89	76 01 125	102	79 32 125	119	87 01 250	133
50 00 250	82	71 22 200 T BKA	89, 210	76 12 125	102	79 32 125 ESD	121	87 01 300	133
50 00 300	82	71 31 200	89	76 22 125	102	79 42 125	119	87 01 400 US	134
50 01 160	82	71 31 200 R	90	76 81 125	102	79 42 125 ESD	121	87 01 560 US	134
50 01 180	82	71 31 250	90	77 01 115	109	79 42 125 Z	119	87 02 180	133
50 01 210	82	71 32 200	89	77 01 130	109	79 42 125 Z ESD	121	87 02 180 T BKA	133, 210
50 01 225	82	71 32 200 T BKA	89, 210	77 02 115	109	79 52 125	119	87 02 250	133
50 01 250	82	71 41 200	89	77 02 115 ESD	111	79 52 125 ESD	121	87 02 250 T BKA	133, 210
50 01 300	82	71 72 460	91	77 02 120 H	112	79 62 125	119	87 02 300	133
51 01 210	83	71 72 610	91	77 02 120 H ESD	113	79 62 125 ESD	121	87 02 300 T BKA	133, 210
55 00 300	83	71 72 760	91	77 02 130	109	81 01 250	122	87 11 250	135
61 01 200	86	71 72 910	91	77 02 135 H	112	81 11 250	122	87 19 250	135

87 21 250	135	92 27 61	152, 222	95 32 060	164	97 49 60	176	97 61 145 A	188
87 21 300	135	92 27 62	152, 222	95 32 100	164	97 49 62	176, 191	97 61 145 F	188
87 22 250	135	92 28 69 ESD	150	95 32 315 A	165	97 49 63	191	97 62 145 A	188
87 26 250 T	211	92 28 70 ESD	150	95 32 320	166	97 49 64	176	97 68 145 A	188, 227
87 28 250 US	136, 221	92 28 71 ESD	150	95 32 340 SR US	167	97 49 65	191	97 71 180	188
87 41 250	137	92 28 72 ESD	150	95 36 250 SBA	162, 225	97 49 65 1	177, 191	97 72 180	188
87 51 250	137	92 32 29	151	95 36 280 SBA	162, 225	97 49 66	191	97 81 180	189
88 01 180	139	92 34 28	151	95 36 315 A	165	97 49 66 1	177, 191	97 90 05	190
88 01 250	139	92 34 36	152	95 36 320	166, 226	97 49 67	191	97 90 06	190
88 01 300	139	92 34 37	152	95 39 250	162	97 49 68	191	97 90 09	190
88 01 400	140	92 37 64	152, 222	95 39 280	162	97 49 68 1	177, 191	97 90 10	190
88 02 180	139	92 38 75 ESD	150	95 39 315 A 01	165	97 49 69 1	176, 191	97 90 12	190
88 02 250	139	92 44 42	153	95 39 315 A 02	165	97 49 69 2	176, 191	97 90 23	190
88 02 250 T BKA	139, 210	92 52 23	153	95 39 320 01	166, 226	97 49 70	176	97 90 24	190
88 02 300	139	92 58 74 ESD	150	95 39 320 02	166, 226	97 49 74	176	97 91 01	191
88 02 300 T BKA	139, 210	92 64 43	153	95 39 720	164	97 49 76	176	98 00 07	228
88 07 300	139, 220	92 64 44	153	95 39 870	164	97 49 81	176	98 00 08	228
88 08 250 US	139, 220	92 67 63	152, 222	95 41 165	159	97 49 82	176	98 00 09	228
89 01 250	142	92 69 84	154	95 59 200 01	156	97 49 83	176	98 00 1/2"	228
90 01 125	142	92 70 46	153	95 61 150 US	167	97 49 84	176	98 00 1/4"	228
90 20 185	142	92 72 45	153	95 61 190	168	97 49 87	176	98 00 10	228
90 25 20	143	92 78 77 ESD	150	95 62 160	169	97 49 90	176	98 00 11	228
90 25 40	144	92 84 18	154	95 62 190	168	97 49 93	176	98 00 12	228
90 29 01	143	92 88 73 ESD	150	95 62 190 T BKA	168, 210	97 49 94	176	98 00 13	228
90 29 02	143	92 94 91	154	95 71 445	169	97 49 95	176	98 00 14	228
90 29 15	143	92 95 89	154	95 71 600	169	97 50 01	177	98 00 15	228
90 29 185	142	92 95 90	154	95 77 600	169, 227	97 51 10	178	98 00 16	228
90 29 40	144	94 10 185	143	95 79 445	169	97 51 12	178	98 00 17	228
90 42 250	144	94 15 215	155	95 79 600	169, 227	97 52 04	181	98 00 18	228
90 42 340	144	94 19 185	143	95 81 600	169	97 52 05	181	98 00 19	228
90 49 340	144	94 19 185 02	143	95 89 600	169	97 52 06	181	98 00 22	228
90 49 340 M	144	94 19 215	155	97 21 215	170	97 52 08	181	98 00 24	228
90 55 280	145	94 35 215	155	97 21 215 B	170	97 52 09	181	98 00 27	228
90 59 280	145	94 55 200	156	97 21 215 C	170	97 52 10	181	98 00 3/4"	228
90 61 16	145	95 02 21	156	97 21 215 SB	170	97 52 13	181	98 00 3/8"	228
90 61 20	145	95 03 160 SB	157	97 22 240	170	97 52 14	181	98 00 5/16"	228
90 70 220	146	95 05 10 SB	158	97 33 01	173	97 52 19	181	98 00 5/8"	228
91 00 200	146	95 05 140	157	97 33 02	173	97 52 20	181	98 00 7/16"	228
91 13 250	147	95 05 155 SBA	158	97 43 05	174	97 52 23	181	98 00 9/16"	228
91 19 250 01	147	95 05 165	158	97 43 06	174	97 52 30	182	98 01 07	230
91 31 180	147	95 05 185	157	97 43 200	174	97 52 33	182	98 01 08	230
91 51 160	148	95 05 190	157	97 43 200 A	174	97 52 34	182	98 01 09	230
91 61 160	148	95 06 230	158, 222	97 49 04	175	97 52 35	182	98 01 1 1/16"	230
91 71 160	148	95 11 165	159	97 49 05	175	97 52 36	182	98 01 10	230
91 92 180	148	95 11 200	160	97 49 06	175	97 52 37	182	98 01 11	230
92 02 53	149	95 12 165	159	97 49 08	175	97 52 38	182	98 01 11/16"	230
92 02 54	149	95 12 165 T BKA	159, 210	97 49 09	175	97 52 50	182	98 01 12	230
92 02 55	149	95 12 200	160	97 49 15	175	97 52 63 DG	184	98 01 13	230
92 08 78 ESD	150	95 12 500	161	97 49 16	175	97 52 64	184	98 01 14	230
92 08 79 ESD	150	95 17 500	161, 224	97 49 18	175	97 52 65	184	98 01 15	230
92 12 52	149	95 16 165 T	211	97 49 19	175	97 52 65 DG	184	98 01 16	230
92 22 04	151	95 18 165 US	159, 223	97 49 20	175	97 53 04	185	98 01 17	230
92 22 06	151	95 18 200 SBA	160, 223	97 49 23	175	97 53 08	187	98 01 18	230
92 22 07	151	95 21 165	159	97 49 24	175	97 53 09	187	98 01 19	230
92 22 12	151	95 22 165	159	97 49 30	175	97 53 14	185	98 01 22	230
92 22 13	151	95 27 600	161, 224	97 49 35	175	97 53 18	186	98 01 3/4"	230
92 22 35	152	95 29 600	161, 224	97 49 40	175	97 59 06	178	98 01 5/16"	230
92 23 05	151	95 31 250 SBA	162	97 49 44	175	97 59 12	178	98 01 5/8"	230
92 24 01	151	95 31 280 SBA	162	97 49 50	176	97 59 14	181	98 01 7/8"	230
92 24 34	152	95 32 038	163	97 49 54	176	97 59 65 2	177, 184	98 01 9/16"	230

98 04 10	231	98 47 3/4"	235	9K 98 98 30 US	249
98 04 13	231	98 47 5/8"	235	9K 98 98 31 US	249
98 04 17	231	98 47 7/8"	235		
98 04 19	231	98 47 9/16"	235		
98 04 22	231	98 49 05	236		
98 05 13	231	98 49 06	236		
98 05 17	231	98 49 08	236		
98 05 19	231	98 52	237		
98 07 250	229	98 53 03	237		
98 14 05	232	98 53 13	237		
98 14 06	232	98 54	237		
98 14 08	232	98 55	237		
98 15 05	232	98 56	238		
98 15 06	232	98 56 09	238		
98 15 08	232	98 62 01	238		
98 30	232	98 62 02	238		
98 31	233	98 64 02	239		
98 33 25	236	98 65 01	239		
98 33 50	236	98 65 02	239		
98 35 125	233	98 65 03	239		
98 35 250	233	98 65 10	239		
98 37 1/2"	235	98 65 20	239		
98 37 10	234	98 65 30	239		
98 37 11	234	98 67 05	240		
98 37 12	234	98 67 10	240		
98 37 13	234	98 90	240		
98 37 14	234	98 99 11	241		
98 37 16	234	98 99 11 S3	243		
98 37 17	234	98 99 11 S4	243		
98 37 19	234	98 99 11 S5	243		
98 37 3/4"	235	98 99 11 S6	243		
98 37 3/8"	235	98 99 12	244		
98 37 5/16"	235	98 99 13	245		
98 37 5/8"	235	98 99 13 S4	245		
98 37 7/16"	235	98 99 13 S5	245		
98 37 9/16"	235	98 99 14	247		
98 39 05	236	98 99 14 LE	247		
98 39 06	236	99 00 200	86		
98 39 08	236	99 00 220	86		
98 40	232	99 00 220 K12	86		
98 41	233	99 00 250	86		
98 42	236	99 00 280	86		
98 43 50	236	99 00 300	86		
98 45 125	233	99 01 200	86		
98 45 250	233	99 01 220	86		
98 47 1"	235	99 01 250	86		
98 47 1/2"	235	99 01 280	86		
98 47 10	234	99 01 300	86		
98 47 11	234	99 10 250	87		
98 47 11/16"	235	99 10 300	87		
98 47 12	234	99 11 250	87		
98 47 13	234	99 11 300	87		
98 47 14	234	99 14 250	87		
98 47 16	234	99 14 300	87		
98 47 17	234	9K 98 98 20 US	248		
98 47 18	234	9K 98 98 21 US	248		
98 47 19	234	9K 98 98 22 US	248		
98 47 22	234	9K 98 98 25 US	248		
98 47 24	234	9K 98 98 26 US	248		
98 47 27	234	9K 98 98 27 US	249		

ACSR Cable Cutter with ratchet action for cables with a steel core	167	Crossover Tweezers.....	154
Adjustable Wrench	229	Cutter for ribbon cable.....	155
Alligator® – Water Pump Pliers	138, 220	Cycle Pliers.....	125
Alligator® XL – Water Pump Pliers.....	140	Diagonal Cutter for fiber optics	95
Anvil Shears for cutting soft material such as rubber and leather.....	156	Diagonal Cutters	93, 94, 218
Automatic Flat Cable Stripping Pliers.....	40	Diagonal Cutters for electromechanics	102
Automatic Insulation Stripper.....	39, 40	Dismantling Knives	237
Automatic Stripping Pliers.....	41	Dismantling Pliers.....	43
Belt pouch.....	198	Dismantling tool for data cables.....	49
Bolt Cutters	91	Dismantling Tools	47, 48
Bolt End Cutting Nippers – high lever transmission.....	86	Duckbill Pliers	61
Bowden Cable Cutter	167	Ear Clamp Pliers	32
Box Wrenches.....	230	Electricians’ Pliers.....	42
Break-off Pliers for vehicle bodywork.....	83	Electricians’ Shears.....	158
Cable Cutters (ratchet action) for steel wire armored cable (SWA-Cable).....	165	Electronic Super Knips®	114, 116
Cable Cutters for Wire Rope and ACSR	169, 227	Electronic Super Knips® XL.....	117
Cable Cutters with ratchet action	162, 225	Electronics Diagonal Cutters	107, 108, 112
Cable Cutters with ratchet action and telescopic handles	164	Electronics Diagonal Cutters ESD.....	110, 113
Cable Cutters with ratchet principle, 3-stage	166, 226	Electronics End Cutting Nippers	104
Cable Knife with replaceable blade	238	Electronics End Cutting Nippers ESD	106
Cable Knives	237	Electronics Mounting Pliers.....	67
Cable Shears	158, 159, 161, 222, 223, 224	Electronics Oblique Cutting Nippers	103
Cable Shears with ratchet action and telescopic handles.....	163	Electronics Pliers	65
Cable Shears with twin cutting edge	160, 223	Electronics Pliers ESD	66
Carpenters’ Pincers.....	82, 83	Electronics Pliers Sets for working on electronic components.....	203
Circlip Pliers for external circlips on shafts	75	Electronics Wire Stripper	34
Circlip Pliers for grip rings on shafts	80	Electronics Wire Stripping Shears.....	34
Circlip Pliers for internal circlips in bore holes	74	End Cutting Nippers	87
Circlip Pliers for large external circlips	73	End Cutting Nippers for mechanics.....	87
Circlip Pliers for large internal circlips.....	73	ErgoStrip® – Universal Dismantling Tool	50
Circlip Pliers Sets	197, 200	Extension Bars.....	233
Circlip Tool for internal and external circlips.....	81	Family Sets	196
CoBolt® – Compact Bolt Cutters	88	Farriers’ Pincers	83
CoBolt® “Fencing”	90	Flat Nose Grozing Pliers.....	148
CoBolt® XL – Compact Bolt Cutters.....	90	Flat Nose Pliers	51, 216
Cobra® – High-Tech Water Pump Pliers	132, 221	Flat Nose Pliers of plastic.....	238
Cobra® ES – High-Tech Water Pump Pliers, extra-slim	137	Flat Nose Pliers with cutting edges.....	52
Cobra® Insulated.....	136	Flush Cutting Diagonal Pliers for Plastics	95
Cobra® QuickSet.....	135	Four-Mandrel Crimping Pliers for turned contacts	183
Cobra® XL/XXL – High-Tech Water Pump Pliers	134	Glass Breaking Pincer	147
Cobra®...matic – High-Tech Water Pump Pliers	135	Glass Nibbling Pincers	148
Combination Pliers	28, 214	Grip Pliers	71
Combination Shears	157	Gripping Pliers.....	60
Compact Bolt Cutters	88, 90	Gripping Pliers for precision mechanics	68
Compact Diagonal Cutter	219	Halogen Bulb Exchange Pliers	60
Compact Diagonal Cutters, high lever transmission.....	98	Hexagon Sockets	234, 236
Compact Tool Case.....	241	High Leverage Center Cutters.....	102
Concrete Mesh Cutter.....	92	High Leverage Combination Pliers	27, 214
Concreters’ Nippers	84	High Leverage Concreters’ Nippers.....	85
Control Cabinet Keys for all standard cabinets and shut-off systems.....	193	High Leverage Diagonal Cutters	99, 100, 219
Crimp Assortments for ferrules (end sleeves).....	190	High Leverage End Cutting Nippers	86
Crimp System Pliers for exchangeable crimping dies	174	High Leverage Flush Cutter for soft metal and plastic.....	96
Crimping Dies for Crimp System Pliers	175, 176	High-Tech Water Pump Pliers	132, 135, 137
Crimping Pliers.....	170	High-Tech Water Pump Pliers, Insulated	136, 221
Crimping Pliers for two-handed operation	180	Hog Ring Pliers.....	148
Crimping Pliers for Western plugs	178	Hose Clamp Pliers for Click Clamps.....	127
Crimping Pliers for wire ferrules (end sleeves).....	188, 227	Installation Pliers.....	45, 216
Crimping Pliers with front loading mechanism for wire ferrules (end sleeves)...	189	Insulated Tools Sets	248
Crimping Pliers with quick changer magazine.....	172	Insulating Mats	240
Crimping Pliers with short design	181	Insulating Plastic Clamp.....	239
Crimping Pliers with side cutter for Scotchlok™ connectors.....	177	Insulation Stripper with replaceable blades.....	35

Insulation Strippers.....	33, 46, 215	Self-adjusting Crimping Pliers with front loading mechanism for ferrules (end sleeves).....	187
Insulation Strippers with Cable Shears.....	44	Self-Adjusting Crimping Pliers with side-loading mechanism for ferrules (end sleeves).....	185
Lineman's Pliers.....	30, 215	Self-Adjusting Insulation Strippers.....	38
Locators for crimping pliers and profiles.....	177	Self-Clamping Slip-On Caps.....	239
Long Nose Pliers.....	59, 218	Shears for KEVLAR® fibers.....	157
Long Reach Needle Nose Pliers.....	56	Sheet Metal Nibbler.....	145
Long Reach Needle Nose Pliers with transverse wave.....	57	SmartGrip® – Water Pump Pliers with automatic adjustment.....	125
Magnetic LED Lamp.....	195	Snipe Nose Pliers of plastic.....	238
Mechanics' Pliers.....	69	Snipe Nose Pliers with Center Cutter.....	56
Mini Pliers Sets in belt tool pouch.....	204	Snipe Nose Side Cutting Pliers.....	53, 54, 55, 217
Mini Water Pump Pliers.....	142	Sockets.....	235
Mini Wire Stripper.....	41	Special Retaining Ring Pliers for retaining rings on shafts.....	80
Mitre Shears for plastic and rubber sections.....	155	Spring Hose Clamp Pliers.....	126
MultiCrimp® – Crimping Pliers.....	172	Spring Hose Clamp Pliers with locking device.....	127
MultiStrip 10 – Automatic Insulation Stripper.....	39	Standard Tool Case.....	244
Needle-Nose Combination Pliers.....	29, 215	Stork Beak Pliers.....	55, 217
Notching Pliers.....	145	Stripping Tool for coaxial cables.....	48
Nut Drivers with T-Handle.....	231	StriX – Insulation Strippers with Cable Shears.....	44
Open End Wrenches.....	228	Telephone Pliers.....	56, 58
Parrot beak pincer.....	146	T-handle.....	232
Pipe and Connector Pliers.....	122	Tile Breaking Pliers.....	147
Pipe Cutter for composite and plastic pipes.....	144	Tile Nibbling Pincer.....	146
Pipe Cutter for composite pipes and protective tubes.....	143	Tool Case "BIG Twin Move".....	205
Pipe Cutter for flexible pipes and flexible hoses.....	142	Tool Case for photovoltaics.....	191
Pipe Cutter for plastic conduit pipes (electrical installation work).....	143	The Tool Drop Protection System.....	208
Pipe Wrenches 45°.....	123	Tool Kits.....	202
Pipe Wrenches 90°.....	123	Tool Pouch.....	198
Pipe Wrenches S-Type.....	124	Tool Roll.....	196, 245
Pipe Wrenches S-Type with rapid adjustment.....	124	Torque Wrench with driving square, reversible.....	236
Plastic Slip-On Caps.....	239	TwinForce® – High Performance Diagonal Cutters.....	99
Pliers and a wrench in a single tool.....	130	TwinKey® for all standard cabinets and shut-off systems.....	192
Pliers Sets.....	204	Twistor16® – Self-Adjusting Crimping Pliers.....	186
Pliers Sets in a foam tray.....	199	Universal Dismantling Tools.....	49
Pliers Sets in plastic deep-drawn packaging.....	201	Universal Grip Pliers.....	70
Pliers Wrench XL.....	130	Universal Key "Construction".....	194
Pliers Wrenches.....	128, 220	Universal Key for all standard cabinets and shut-off systems.....	194
PreciForce® – Crimping Pliers.....	182	Universal Tool Case.....	246
Precision Circlip Pliers for internal circlips in bore holes.....	76	Vinyl Shears for cable ducts.....	156
Precision Circlip Pliers Sets.....	200	Water Pump Pliers.....	138, 142, 220
Precision Circlip Pliers to assemble external circlips on shafts.....	78	Water Pump Pliers with automatic adjustment.....	125
Precision Electronics Diagonal Cutters.....	118	Welding Grip Pliers.....	72
Precision Electronics Diagonal Cutters ESD.....	120	Wire Rope Cutter.....	169
Precision Electronics Gripping Pliers.....	64	Wire Rope Shears.....	168
Precision Insulation Strippers with replaceable blades.....	36	Wire Stripping Tweezers – Coated.....	46
Precision Mechanics Pliers.....	52	X-Cut® – Compact Diagonal Cutter.....	98, 219
Precision Tweezers.....	149, 151, 152, 153, 154, 222		
Precision Tweezers ESD.....	150		
Profi-Key for all standard shut-off systems.....	193		
PUK® Junior Hacksaw.....	240		
Punch Lock Riveters.....	144		
Raptor™ Pliers.....	136		
Relay Adjusting Pliers.....	61		
Reversible Ratchet.....	233, 236		
Revolving Punch Pliers.....	146		
Round Nose Pliers.....	52, 216		
Round pliers with cutting edge.....	51		
Safety Compact Tool Case.....	242		
Safety Tool Rolls.....	245		
Screwdrivers.....	232		
Self-adjusting crimping pliers for end sleeves (ferrules) with rotating crimp head.....	186		

BASIC SHAPES OF THE JAWS

flat jaws



half-round jaws



round jaws



Cutting Pliers
for cutting or nipping (diagonal, centre and end cutters, carpenters' pincers, etc.)



Gripping Pliers
(flat-, long-nose and water pump pliers, etc.)

JOINT CONNECTIONS



Forged-in joint axle
The rivet is part of one handle (forged from one piece)
> high stability for highest strain
> long service life

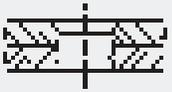

Joint with inserted rivet
A proven, sturdy and precise rivet connection for all standard pliers.

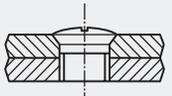

Bolted joint
For particularly demanding requirements in terms of precision and smooth operation, e.g. in circlip pliers and cable shears (even the finest multi-stranded conductors have to be cut cleanly).



Combined Pliers
for cutting and gripping (combination, stork beak and radio pliers, etc.)



Special Pliers
for special applications, e.g. notching or punching different types of materials (sheet-metal nibbler, tile nibbling pincers, etc.)

TYPES OF JOINTS

Lap joint

The two pliers halves lie on top of each other but are not milled out.

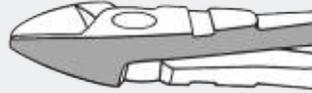

Single joint

Half the thickness in each pliers handle is milled away in the joint area so that both handles can be laid into each other.

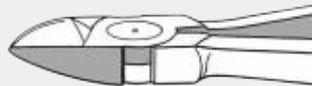

Box joint

One handle on the pliers is slit. The other handle is pushed through this slot. This joint connection can withstand a high level of load and strain because the joint bolt is supported on both sides and the inside handle is guided on both sides.

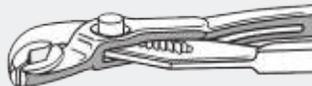

point

gripping surface

recess (pipe grip)

jaw

flank

additional cutting edge

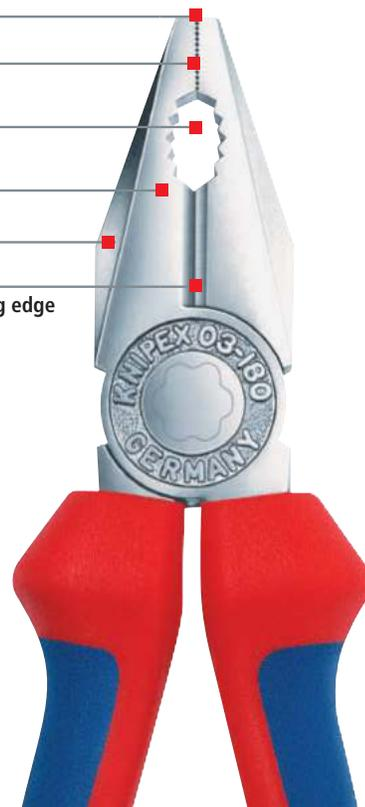

Safety instructions

- Each tool should only be used for its specified purpose.
- When using cutting pliers: beware of wire ends flying off. Wear protective goggles and – if needed – gloves. Be aware of bystanders!
- Only handles marked with the symbol  1000V are insulating.

Care Tips

A drop of oil on polished surfaces and in the joint will keep the tool in good working order and will increase the service life of your pliers.



The maximum values always indicate the performance limit under the most favorable cutting conditions, when the wire is placed as near as possible to the joint.

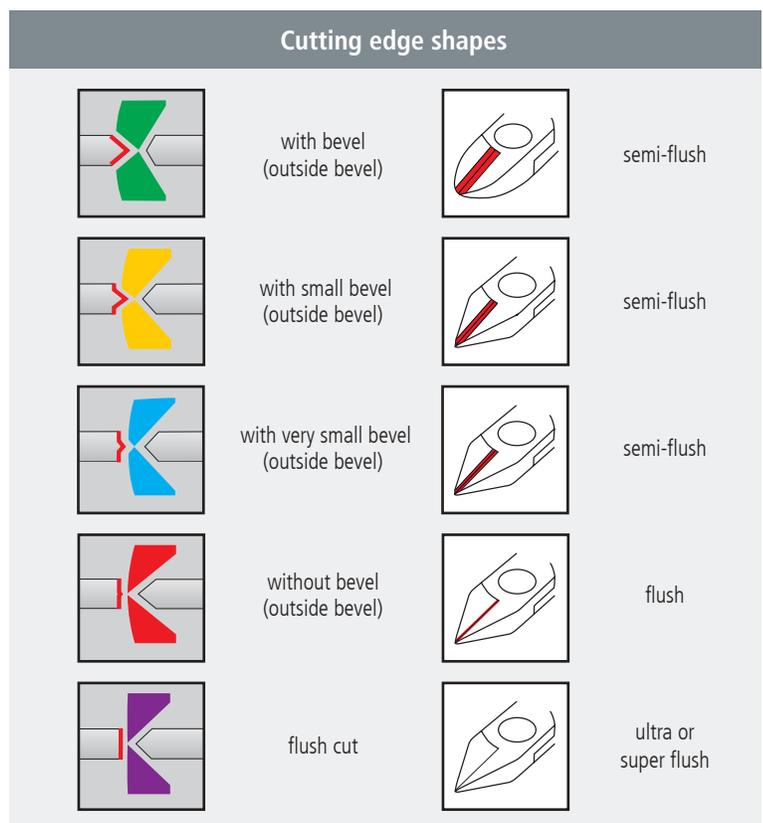
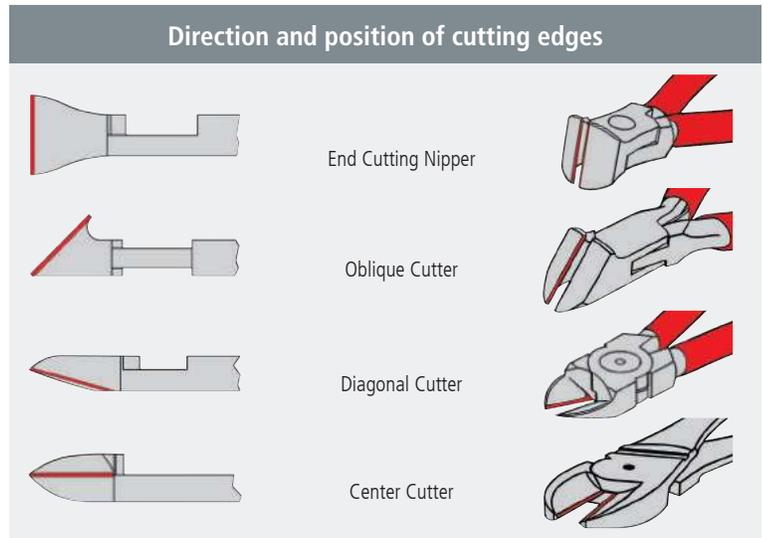

WIRE CLASSES

	Material examples	Type of wire	Tensile strength	
			N/mm ²	kp/mm ²
	Copper, plastics	soft	220	22
	Nail, wire pin	medium-hard	750	75
	Wire rope strand, steel wire	hard	1800	180
	Spring steel wire	piano wire	2300	230



STRUCTURE OF THE ARTICLE NUMBER HEAD / HANDLES

Basic model e.g.: Combination Pliers	Style e.g.: straight	Finish e.g.: head polished, handles plastic coated	Length e.g.: 180 mm
03	0	1	180



- 0** Pliers black atamentized, head polished 
- 1** Head polished, handles plastic coated 
- 2** Head polished, handles with multi-component grips 
- 3** Pliers chrome plated, handles plastic coated 
- 4** Pliers chrome plated 
- 5** Pliers chrome plated, handles with multi-component grips 
- 6** Pliers chrome plated, handles insulated with multi-component grips VDE-tested
DIN EN/IEC 60900 
- 7** Pliers chrome plated, handles with dipped insulation, VDE tested
DIN EN/IEC 60900 
- 8** Pliers head polished, handles with multi-component grips; ASTM-tested 



SYMBOLS

	flat jaws		with lead catcher		electrostatic discharging, dissipative		weight
	half-round jaws		angle		electronics		length
	round jaws				VDE tested, also in conformance to GPSG (Equipment and Product Safety Act)		soft wire
	flat and pointed jaws				insulated according to IEC 60900 and ASTM F1505, usable up to 1000 V AC/1500 V DC		medium hard wire
	box joint		centre cutter		insulated according to DIN VDE 0680/1, suitable for the application up to 1000 V AC / 1500 V DC		hard wire
	bolted joint		cutting edges with bevel		conforms to a European directive		piano wire
	smooth gripping surfaces		cutting edges with small bevel		mechanically tested in accordance with the equipment and product safety act		Cu + Al multi-conductor cable, solid and multi-stranded
	serrated gripping surfaces		cutting edges with very small bevel		WEEE marking (Waste Electrical and Electronic Equipment Directive)		wire rope
	cross-hatched, knurled gripping surfaces		cutting edges without bevel				iron
	with opening spring		for flush cut of soft materials				ribbon cable
							steel wire armoured cable (SWA)

Registered Trademarks of the companies

Con-Pearl®	PARAT-WERK Schönenbach GmbH + Co. KG
gesis®	Wieland Electric GmbH
Kapton®, KEVLAR®	E. I. du Pont de Nemours and Company
Radox®	HUBER+SUHNER AG
Phillips®	Phillips Screw Company
Pozidriv®	European Industrial Service Ltd.
systainer®	TANOS GmbH
Mini-Fit®, Micro-Fit™	Molex® Inc.
MC®	Multi-Contact AG
Solarlok®	Tyco Electronics
Torx®	Acument Global Technologies, Inc.



KNIPEX-Werk
C. Gustav Putsch KG
Wuppertal, Germany

KNIPEX Tools
1500 Busch Parkway
Buffalo Grove, IL 60089

Tel 847 398 8520
Fax 847 398 8526

info@knipex-tools.com
www.knipex-tools.com